

IRRIGATION PUMPING
Table of Contents- Section 900

| PARAGRAPH | PAGE |
|--|-------------|
| 900.1 GENERAL..... | 1 |
| 900.2 METERING REQUIREMENTS..... | 1, 2 |
| 900.3 CUSTOMER'S CONTROL EQUIPMENT..... | 2 |
| 900.4 SERVICE CONDUCTOR REQUIREMENTS..... | 2 |
| 900.5 RECOMMENDATIONS & SPECIFICATION (below 500ft.) | 3 |
| 900.6 TYPICAL STAND ALONE SERVICE ENTRANCE SUPPORTS FOR SERVICE EQUIPMENT | 4 |
| 900.7 TYPICAL IRRIGATION INSTALLATION..... | 5 |
| 901.0 TYPICAL UNMETERED SPRIKLER CONTROL..... | 6 |
| 902.0 CLEARANCES ABOVE GROUND, THOROUGHFARES, ROADWAYS, ETC. IN AGRICULTURAL AREAS..... | 7 |
| 903.0 TYPICAL CUSTOMER TRANSFORMER BANK (Pad Mounted)..... | 8 |
| 903.0 ELEVATION MAP..... | 9 |



900.0 IRRIGATION PUMPING

900.1 GENERAL

1. Permits and inspection may be needed. Check with governing inspection agency in the area.
2. All pump control panels, main disconnect and metering panels shall be weatherproof.
3. Across-the-Line starting is normally acceptable up through 75 horsepower at 480 volts. There may be circumstances which require reduced voltage starting in some areas. Check with your local APS Customer Service Representative in the initial Planning Stages Regarding starting requirements.
4. When a water pumping or irrigation customer requests a 3-phase 240 volt or 480 volt service, the Customer shall provide for and APS will furnish a 3-phase 4-wire 120/240 or 277/480 volt grounded neutral service to the service entrance. Customer meter can and main disconnect shall be 3-phase 4wire equipment. (See section 200, Paragraph 201.2 and page 6 of this section)
5. The main switch shall be immediately adjacent to the meter panel. (See Section 300, Paragraph301.3) Meters and metering equipment shall be located ahead of or on the supply side of the customer's main disconnect. (See Section 300, Paragraphs 301.14 and 302.3)
6. Where current limiting fuses are required in the main switch, the fuse holder shall not permit insertion of fuses that are not current limiting. All main disconnects shall simultaneously open all conductors of the circuit. All ungrounded conductors shall be fused in the main disconnect.
7. A 3-pole circuit breaker (interrupting all three phases) may be substituted for the main fused disconnect switch provided it is properly sized for the equipment and can safely interrupt the available fault current.
8. Please refer to 104.3 for motor starting.

900.2 METERING REQUIREMENTS

1. **100 Ampere Meter Box.**
 - a. Where the name plate horsepower rating of any motor or group of motors does not exceed **25 HP** at **240** volts **3 ϕ 4W** or **50 HP** at **277/480** volts **3 ϕ 4W**, factory bussed safety socket meter box with test blocks rated at 100 ampere minimum continuous duty shall be installed by the Customer. (See Section 300, page21)
 - b. The meter socket for 240 volt 3 ϕ 4W Delta or a 277/480 volt 3 ϕ 4W Wye shall be 7-clip. Socket shall be rated 100 ampere continuous duty. (See Section 300, pages 29, Figures 6 & 7)
 - c. The total actual continuous operating load current, excluding motor starting current, shall not exceed 100 amperes.

900.2 METERING REQUIREMENTS Cont'd

2. 200 Ampere Meter Box.

- a. Where the name plate horsepower rating of any motor or group of motors does not exceed 125 horsepower at 277/480 volt 3 ϕ 4W Wye, a factory busssed safety socket meter box with test blocks rated at 200 amperes continuous duty shall be installed by the Customer. (See Section 300, page 22)
 - b. The meter socket for 277/480 volt 3 ϕ 4W Wye shall be 7 dip. Socket shall be rated 200 ampere continuous duty. (See Section 300, page 29, Figures 6 & 7)
 - c. The total actual continuous operating load current, excluding meter starting current, shall not exceed 175 amperes.
3. Where the name-plate horsepower rating of any mot or group of motors exceeds the 125 horsepower and /or the total actual operating load current, excluding motor starting current, for any reason exceeds 175 amperes, either at the time of installation or thereafter, the Customer shall install facilities consisting of an approved meter/CT box or an approved switched to accommodate current transformer metering. (See Section 300, Pages 37-71)
 4. No Customer conductors or conduit shall be in any sealable area.

900.3 CUSTOMER'S CONTROL EQUIPMENT

1. Three element running overload protection shall be required on all motors.
Example—one overload unit in each phase is the starter.
2. Under voltage, phase failure and phase reversal protection, time—delay back spin relays, surge capacitor and lightning arresters are strongly recommended for the protection of each pump motor installation.
3. All reduced voltage starters shall be automatically switched from Start to Run mode of operation. Manual Transfer is not acceptable. The timing relay shall be set such that the line current when switched to the Run mode does not exceed the initial starting line current.
4. All reduced voltage starters shall employ closed transition switching. Exceptions to be approved by APS Division Engineering for a specific installation.
5. Customer's switch and motor control equipment shall be of proper horsepower and voltage rating and shall be weatherproof.
6. Customers switch and motor control cover shall be effectively locked or sealed if the enclosure contains accessible electrically energized parts.
7. From starter to motor, conduits shall be flexible liquid-tight (20 feet maximum recommended length) and each shall contain an equipment bonding jumper along with the phase conductors. If parallel conduits there shall be a bond wire in each.

900.4 SERVICE CONDUCTOR REQUIREMENTS

For overhead clearances of services see section 400, paragraphs 401.0 and 401.0-3.

For underground service requirements see section 500—Underground Service and Section 600 Trenching Requirements.

| RECOMMENDED AND SPECIFICATIONS FOR 3Ø PUMP INSTALLATION FOR OVERHEAD (FOR UNDERGROUND REQUIREMENTS SEE SECTION 500) | | | | | | | | | |
|--|---------------------------|---------------------|-----------------------|-----------------------------|---|--------------------------|-----------------------------------|-------------------------|--|
| Motor H.P. | Motor Amps F.L.A. PER NEC | Amps @ 125% PER NEC | Main Switch Amp (Min) | Fuse Duel Element Amp (Min) | Copper Wire 75° C Rating Terminations must indicate min 75° C (Min) | *Equip Ground Cond (Min) | Riser Conduit Size (Note 9) (Min) | Starter Size NEMA (Min) | Sys Fault Amps at the SES (Note 8) (Max) |
| 1 | 2 | 3 | 4 | 5 | 6 | 7 | 8 | 9 | 10 |
| 240 Volts 3Ø 4W 100A. Self-Contained Meter. 7 - Terminal Socket & Test Block | | | | | | | | | |
| 10 | 28 | 35 | 60 | 40 | 8 | 10 | 1" | 2 | 14,000 |
| 15 | 42 | 53 | 60 | 60 | 4 | 10 | 1" | 2 | 14,000 |
| 20 | 54 | 68 | 100 | 80 | 3 | 8 | 1 1/4" | 3 | 14,000 |
| 25 | 68 | 85 | 100 | 100 | 1 | 8 | 1 1/4" | 3 | 14,000 |
| 277/480 Volts 3Ø 4W 100A. Self-Contained Meter. 7 - Terminal Socket & Test Block | | | | | | | | | |
| 10 | 14 | 18 | 30 | 20 | 12 | 12 | 1" | 1 | 10,000 |
| 15 | 21 | 26 | 30 | 30 | 10 | 10 | 1" | 2 | 10,000 |
| 20 | 27 | 34 | 60 | 40 | 8 | 10 | 1" | 2 | 10,000 |
| 25 | 34 | 43 | 60 | 50 | 6 | 10 | 1" | 2 | 10,000 |
| 30 | 40 | 50 | 60 | 60 | 4 | 10 | 1" | 3 | 10,000 |
| 40 | 52 | 65 | 100 | 80 | 3 | 8 | 1 1/4" | 3 | 10,000 |
| 50 | 65 | 81 | 100 | 100 | 1 | 8 | 1 1/4" | 3 | 10,000 |
| 277/480 Volts 3Ø 4W 200A. Self-Contained Meter. 7 - Terminal Socket & Test Block | | | | | | | | | |
| 60 | 77 | 96 | 200 | 100 | 1 | 8 | 1 1/4" | 4 | 14,000 |
| 75 | 96 | 120 | 200 | 125 | 1/0 | 6 | 1 1/4" | 4 | 14,000 |
| 100 | 124 | 155 | 200 | 175 | 2/0 | 6 | 2 1/2" | 4 | 14,000 |
| 125 | 156 | 195 | 200 | 200 | 3/0 | 6 | 2 1/2" | 5 | 14,000 |
| 277/480 Volts 3Ø 4W 400 amp C.T./Meter Can | | | | | | | | | |
| 150 | 180 | 225 | 400 | 250 | 250kcmll | 4 | 2" | 5 | 25,000 |
| 200 | 240 | 300 | 400 | 350 | 500kcmll | 3 | 3" | 5 | 25,000 |
| 250 | 302 | 378 | 400 | 400 | 600kcmll | 3 | 3" | 6 | 25,000 |
| 277/480 Volts 3Ø 4W 600 amp C.T./Meter Can | | | | | | | | | |
| 300 | 361 | 451 | 600 | 500 | 2-250kcmll | 2#2 | 2-2" | 6 | 30,000 |
| 350 | 414 | 518 | 600 | 550 | 2-300kcmll | 2#1 | 2-2" | 6 | 30,000 |
| 400 | 477 | 596 | 600 | 600 | 2-350kcmll | 2#1 | 2-2 1/2" | 6 | 30,000 |
| 277/480 Volts 3Ø 4W 800 amp C.T./Meter Can | | | | | | | | | |
| 450 | 515 | 644 | 800 | 700 | 2-500kcmll | 2-1/0 | 2-3" | 7 | 30,000 |
| 500 | 590 | 738 | 800 | 800 | 2-600kcmll | 2-1/0 | 2-3" | 7 | 30,000 |
| * Equip. ground conductor refers to bond conductor size on load side of fuses. For bonding requirements on line side of fuses, See Section 700, Paragraph 701.0 Column 3. | | | | | | | | | |

NOTES:

1. All 3Ø services to be served 4 wire.
2. See section 700 for Bonding & Grounding Requirements.
3. See section 300, pages 21 and 22 for 100 & 200 Amp Meter Can Requirements.
4. See sections 300, pages 59 and 43 for 400 Amp Meter, C.T. Requirements.
5. See Section 300, pages 61 and 43 for 600 Amp Meter, C.T. Requirements.
6. See section 300, page 43 for 800 Amp Meter, C.T. Requirements.
7. See section 500 for underground installation.
8. Minimum interrupting and bracing capabilities to be provided by the Customer in his service equipment.
9. Riser conduit size for overhead installation only. See section 500 for underground requirements

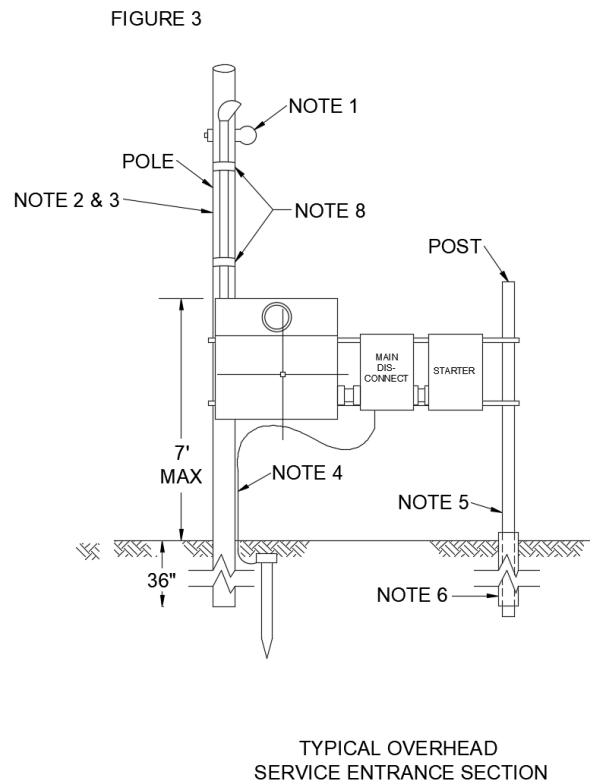
**NOTES:**

1. See Section 400, Paragraphs 401.0 to 401.0-3 for Minimum service heights.
2. See Section 700 - Grounding and Bonding.
3. Pole furnished by customer. See Section 400, Paragraphs 402.2-3 & 402.3 for pole requirements.
4. The post shall be placed in the center of a 12-inch minimum diameter concrete footing. The footing shall be a minimum of 36 inches in the ground and extend a minimum of 4 inches above ground level, and have $\frac{1}{2}$ inch slope away from the post to allow for drainage.
5. All steel or unistrut shall be attached to pole or post securely with a $\frac{1}{2}$ ' minimum galvanized through bolt with a 1-1/2' galvanized backing and lock nut. All services equipment shall be securely fastened to boards or steel with minimum $\frac{1}{4}$ " through bolts. Lag screws shall not be acceptable.
6. Conduit support not over 6 feet apart.
7. See Section 300, Paragraph 306.0 for complete breakdown of requirements
8. Pipe strap supports not over 6'-0" apart.

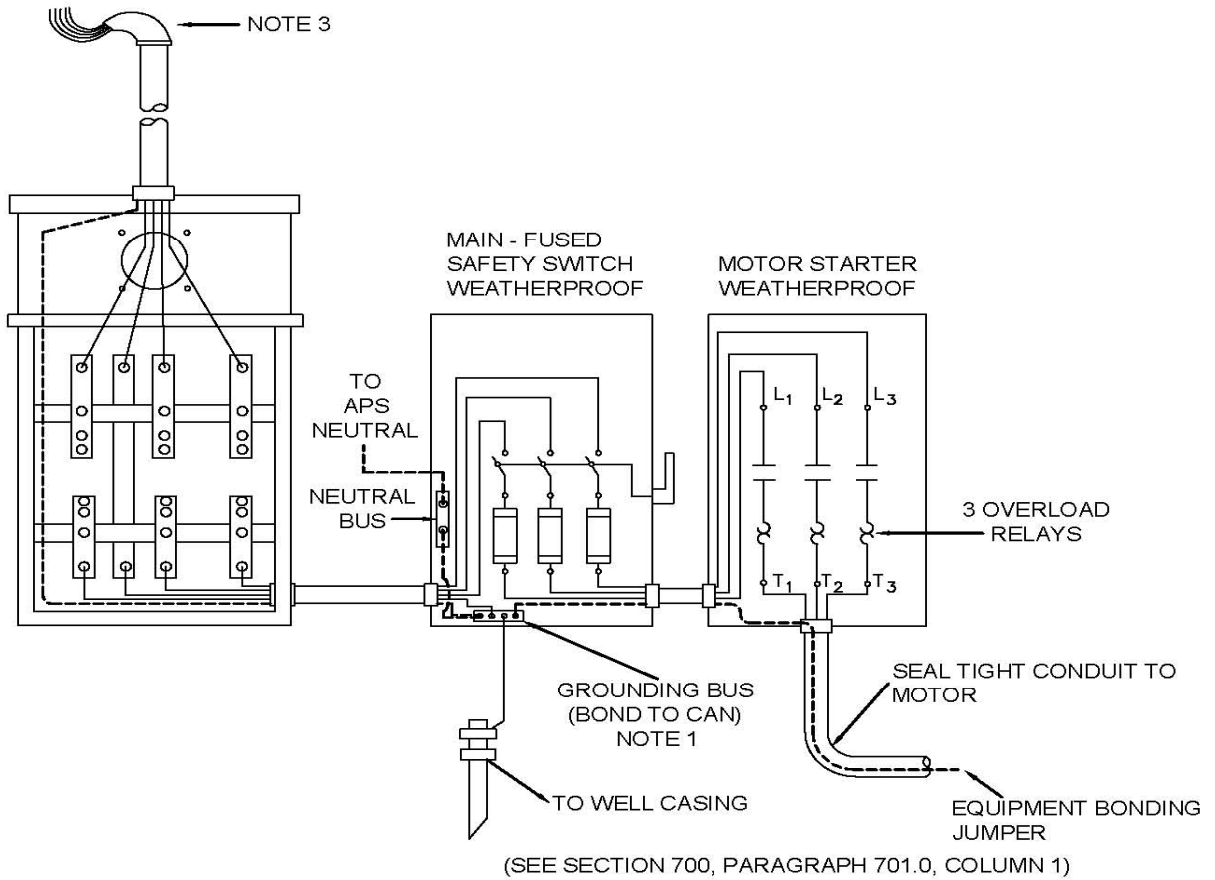

NOTES:

1. Neutral conductor to run through meter can, into main disconnect enclosure where it shall land on a neutral bus bar. All grounding and bonding shall be made on a grounding bus bar. Main bond jumper is required. Neutral need not go any further than the main disconnect if no single phase load is needed.
2. For Bonding and Grounding sizes, see Section 700, Paragraph 701.0
3. See Section 400 for overhead conductor heights and requirements.
4. See Section 500 and 600 for underground installations.
5. For Metering Specification, see Section 300 and 1100.
6. See Sections 306.0 and 306.1 for typical stand-alone service entrance supports for service equipment.

TYPICAL UN-METERED SERVICE (FOR METERED INSTALLATIONS, SEE SECTION 500 PARAGRAPH 506.7) 15 AMP MAXIMUM, 120V 1Ø 2 WIRE OR 120/240V 1Ø 3 WIRE, CONSTANT LOAD:

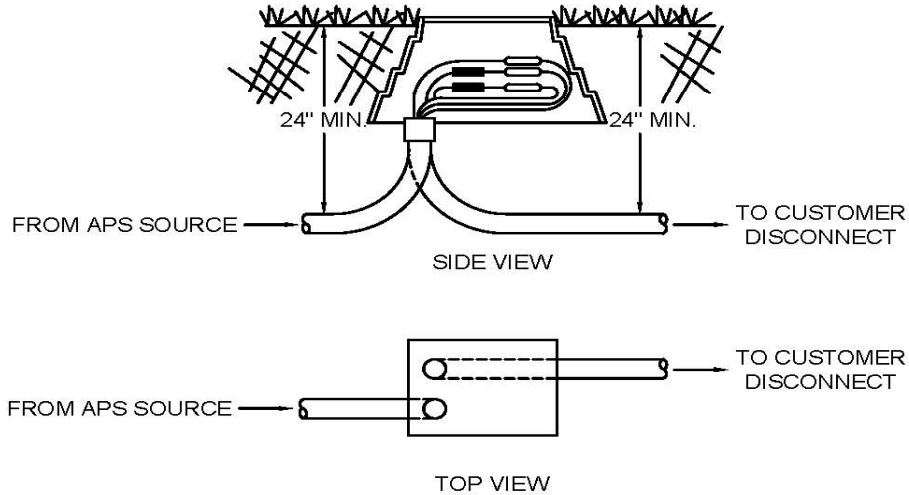

NOTES:

1. Installation shall be per NEC and approved by local jurisdiction having authority.
2. Customer disconnect is required per N.E.C. also requires permanent ID tag.
3. Installation shall be an all conduit systems with a minimum size 1 inch conduit. A 12 radius sweep is acceptable for 1' conduit.
4. See Section 500, Paragraph 502.0 for requirements for conduit system.
5. See Section 500, Paragraph 501.4 regarding coating required on steel conduit below grade.
6. Before digging or diving ground rod, be sure to call blue stake to get location of underground facilities, (See Section 100, Paragraph 100.12)
7. 5/8' X 8' ground rod to be installed at customer disconnect location. Rod must be 8' in the ground.
8. A #4 minimum copper ground wire is to be required for the ground rod connection.
9. Access shall be provided to J-box, with a minimum of 3 feet working clearance required in front of at least two adjacent sides of the box
10. Customer to extend conduit to an APS supplied, Customer installed J-box. APS shall specify J-box type and location. Customer to install j-box per APS specifications.(See local representative)
11. J-boxes shall not be installed in areas exposed to vehicular traffic.
12. Customer to install conductors to APS J-box. APS to terminate service in box.
13. APS provided and installed fuses shall be required at j-box termination. APS "Point-of-Delivery" shall be the fused connection in the J-box.
14. For conduit system design between the j-box and the APS source, see Section 500 Paragraph 502. 12-1 and 502.12-2.

CLEARANCES ABOVE GROUND, IN AGRICULTURAL AREAS-
(TYPICAL CUSTOMER TRANSFORMER BANK)

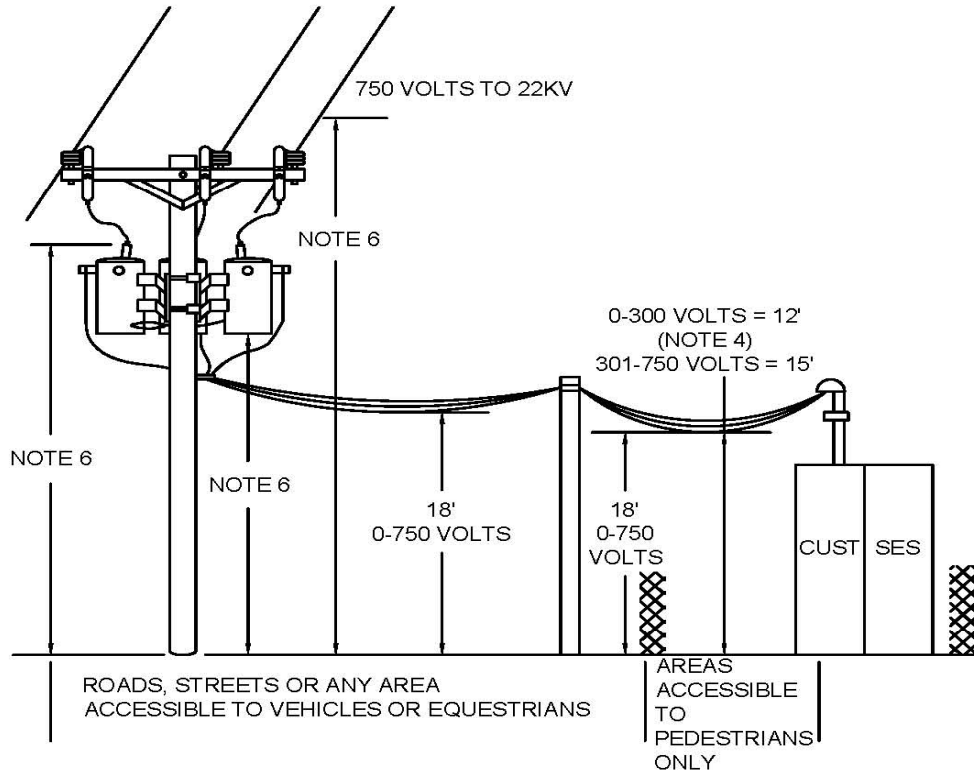

NOTES:

1. All clearances shown are minimums.
2. See Section 400 for clearances from building and other clearances.
3. When it is reasonable to assume vehicles higher than 14 feet will be operating under the line, the clearance shall be increased by the difference between 14 feet and the height of the vehicles.(e.g.--- vehicle 17 feet high---raise the lines an additional 3 feet)
4. If service is not tied to system neutral, clearance must be 15 feet.
5. See paragraph 100.18 section 100, pages 3, 4, 5 and 6 for safe working clearance from electric lines.
6. For minimum heights to transformers and high voltage conductors (over 750 volts) please contact APS Divisions Engineering.

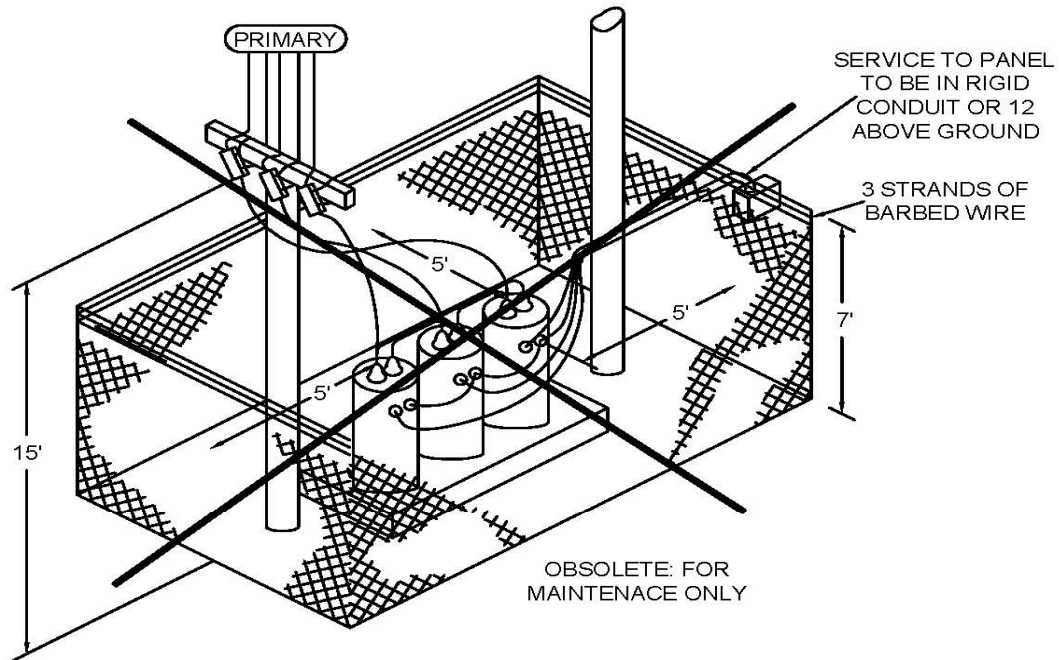
**NOTES:**

1. Fencing shall be required if.
 - a. The platform or bottom of transformers is less than 14 feet above grade.
 - b. The platform braces extend to less than 10 feet above grade.
2. Fencing when required shall consist of chain-link type fence a minimum of 3 strands of barbed wire above the chain-link for total of 7 in height minimum. No part of the fence shall be less than 5 feet from any live parts on the transformer(s), or bare conductor. At least one (1) "Danger High Voltage" sign shall be on each side of the fence (lettering shall be minimum 1' block letters) the fence shall be effectively grounded.
3. The fenced area must be accessible to APS personnel. Customer to install a locking device that will allow one APS lock and one Customer lock on the gate.

