

MANUFACTURING REQUIREMENTS

Table of Contents - Section 1100

PARAGRAPH/DRAWING		PAGE
1100.0	METERING AND SERVICE EQUIPMENT MANUFACTURING REQUIREMENTS.....	1
1100.1	EUSERC - ELECTRIC UTILITY SERVICE EQUIPMENT REQUIREMENTS COMMITTEE.....	1
1100.2	REQUIRED APPROVAL FOR METERING IN SERVICE EQUIPMENT.....	1
1100.3	SWITCHBOARD SERVICE SECTION	1
1101.0	APS DRAWINGS - MISCELLANEOUS SERVICE EQUIPMENT	2
1101.1	LOW-PROFILE SWITCHBOARD	2
	0 - 600 VOLTS, 0 - 3000 AMPS	
1101.2	COMBINATION INSTRUMENT TRANSFORMER & METER BOX	4
	0 - 600 VOLTS, 400 AMP	
1101.3	COMBINATION INSTRUMENT TRANSFORMER & METER BOX	5
	0 - 600 VOLTS, 400 - 600 AMP	
1102.0	EUSERC DRAWINGS - LOW VOLTAGE SERVICE EQUIPMENT	6
1102.1	SWITCHBOARD SERVICE SECTION ILLUSTRATIONS	6
1102.2	APS ADDENDUMS TO EUSERC DRAWINGS	6
DWG 300	MISCELLANEOUS REQUIREMENTS - SHEETS 1 – 19	300
DWG 301	RESIDENTIAL COMBINATION METER PANEL, 225 AMP, MAX. 0 - 600 VOLTS	301
DWG 301B	RESIDENTIAL COMBINATION METER PANEL, 225 AMP, 0 - 600 VOLTS	301B
DWG 302	RINGLESS METER PANEL FOR SINGLE FAMILY RESIDENTIAL	302
	UNDERGROUND SERVICE 400 AMPERE (CLASS 320), 120/240 VOLT, 1 PHASE, 3 WIRE	
302/APS	APS ADDENDUM TO EUSERC DWG 302	302/APS
DWG 302A	METER PANEL WITHOUT SOCKET BYPASS FACILITY RESIDENTIAL	302A
	UNDERGROUND SERVICE 400 AMPERE (CLASS 320), 120/240 VOLT, 1 PHASE, 3 WIRE	
DWG 304	SAFETY SOCKET BOX WITH FACTORY INSTALLED TEST- BYPASS FACILITIES.....	304
	100 AMPERE, 0-600 VOLTS	
304/APS	APS ADDENDUM TO EUSERC DWG 304	304/APS
DWG 305	SAFETY SOCKET BOX WITH FACTORY INSTALLED TEST- BYPASS FACILITIES.....	305
	200 AMPERE, 0-800 VOLTS	
305/APS	APS ADDENDUM TO EUSERC DWG 305	305/APS
DWG 305A	COMBINATION SAFETY-SOCKET PANEL WITH FACTORY INSTALLED TEST BLOCKS	305A
	AND SERVICE DISCONNECT, 100 & 200 AMPERES, 0-600 VOLTS	
305A/APS	APS ADDENDUM TO EUSERC DWG 305A	305A/APS
DWG 306	SELF-CONTAINED METERS INSTALLED IN SWITCHBOARDS	306
306/APS	APS ADDENDUM TO EUSERC DWG 306	306/APS
DWG 307	TYPICAL UNDERGROUND SERVICE AND METER POST, 200 AMP MAXIMUM.....	307
DWG 308	COMMERCIAL HINGED TOP SERVICE PEDESTALS 0-200 AMPERES, 0-600 VOLTS	308
DWG 308A	DUAL SOCKET COMMERCIAL HINGED TOP SERVICE PEDESTAL	308A
	0-400 AMPERES, 0-600 VOLTS, SINGLE PHASE	
DWG 309	COMMERCIAL FIXED TOP SERVICE PEDESTALS, 0-200 AMPS, 0-600 VOLTS	309
DWG 311	TEST BYPASS/DISCONNECT BLOCK FOR SAFETY SOCKETS	311
	100 AND 200 AMPERES, 0-600 VOLTS	
DWG 312	TEST BYPASS/DISCONNECT BLOCK FOR SAFETY SOCKETS 100 AND 200 AMPERES	312
	0-600 VOLTS (BUSSED AND/OR CABLE TERMINATIONS)	
DWG 313	COMBINATION CURRENT-TRANSFORMER CABINET AND METER SOCKET PANEL	313
	FOR OVERHEAD SERVICE 400-800 AMPERES, MAXIMUM 0-600 VOLT	
313/APS	APS ADDENDUM TO EUSERC DWG 306	313/APS
DWG 315	COMBINATION DISCONNECTING DEVICE AND TERMINATING ENCLOSURE	315
	1200 AMPERES, 0-600 VOLT	



MANUFACTURING REQUIREMENTS

Table of Contents - Section 1100

PARAGRAPH/DRAWING	PAGE
DWG 319	319
319/APS	304/APS
DWG 320	320
320/APS	320/APS
DWG 322	322
322/APS	322/APS
DWG 324	324
324/APS	324/APS
DWG 325	325
325/APS	325/APS
DWG 326	326
326/APS	326/APS
DWG 327	327
327/APS	327/APS
DWG 328A	328A
328A/APS	328/APS
DWG 329A	329A
329A/APS	329/APS
DWG 330	330
DWG 331	331
DWG 332	332
332/APS	332/APS
DWG 339	339
DWG 342	342
DWG 343	343
DWG 345	345
DWG 347	347
DWG 348	348
DWG 349	348
DWG 353	353
DWG 354	354



MANUFACTURING REQUIREMENTS

Table of Contents - Section 1100

PARAGRAPH/DRAWING		PAGE
1103.0	EUSERC DRAWINGS – HIGH VOLTAGE SERVICE EQUIPMENT.....	7
1103.1	APS ADDENDUMS TO EUSERC DRAWINGS.....	7
DWG 400	MISCELLANEOUS REQUIREMENTS - SHEETS 1 – 6	400
DWG 401	HIGH VOLTAGE METERING ENCLOSURE 2400 TO 15000 VOLT SERVICE	401
401/APS	APS ADDENDUM TO EUSERC DWG 401	401/APS
401/APS-1	HIGH VOLTAGE BUS ISOLATION SWITCH 2400 TO 25000 VOLT SERVICE	401/APS-1
DWG 407	INDOOR CURRENT TRANSFORMER DIMENSIONS FOR METERING PURPOSES	407
	5000-15000 VOLTS	
DWG 408	HINGED METER PANEL WITH SINGLE SOCKET FOR 2400 TO 27000 VOLT SERVICE	408
DWG 418	UNDERGROUND SERVICE TERMINATING PULL SECTION 5000 TO 15000 VOLT SERVICE ...	418
407/APS	APS ADDENDUM TO EUSERC PAGE 407/APS	407/APS



1100.0 METERING AND SERVICE EQUIPMENT MANUFACTURING REQUIREMENTS

1100.1 EUSERC - ELECTRIC UTILITY SERVICE EQUIPMENT REQUIREMENTS COMMITTEE

Switchboard service sections approved for use in the area served by APS are built to the standards developed by the Electric Utility Service Equipment requirements Committee, and are available to the Customer through electric wholesale distributors.

1100.2 REQUIRED APPROVAL FOR METERING IN SERVICE EQUIPMENT

When a Customer proposes to install a multi-meter panel assembly or service section, the customer shall submit drawings and information to APS for review and approval in accordance with the submittal requirements described in ESRM 302.9.

1100.3 SWITCHBOARD SERVICE SECTION

A standard switchboard service section is a free-standing unit of switchgear which contains bussing for the termination of service entrance conductors, bussing for the connection and mounting of current transformers, panels for the installation of the test switch and meter socket, a service main disconnect switch or breaker, and in many cases, distribution feeder breakers or switches.

The standard switchboard service section is usually built to serve the Customer with heavy electrical supply needs, and is available with service main switch or breaker ratings from 200 amperes through 3000 amperes. For sections above 3000 amperes, consult APS.

Standards for service switchgear have also been developed for self-contained meters, both residential and non-residential, and with either standard duty or heavy duty sockets. These sections of switchgear are built on special order to meet the needs of the Customer's service.

1101.0 MANUFACTURING REQUIREMENTS - APS DRAWINGS

1101.1 LOW-PROFILE SWITCHBOARD

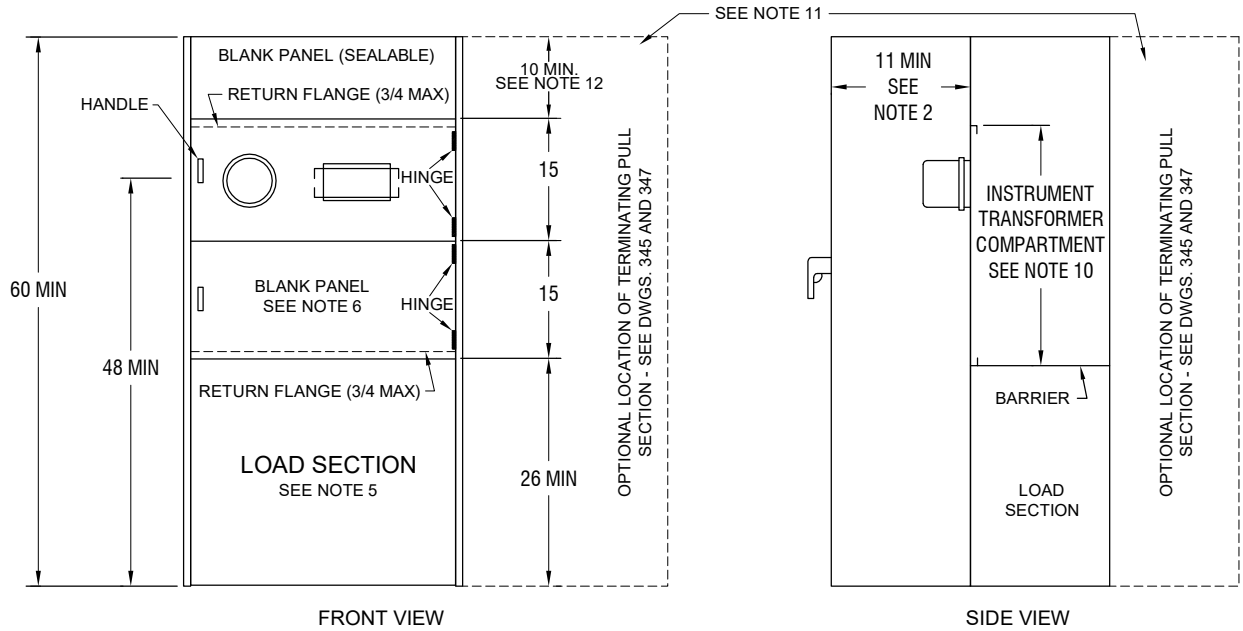

APS DWG. 1101.1
ALL DIMENSIONS SHOWN ARE IN INCHES

NOTES:

1. Terminating pull section shall be located beside or behind the instrument transformer compartment.
2. For outdoor applications only. See EUSERC Dwg. 354 for weatherproof enclosure requirements.
3. Instrument transformer compartments shall be bussed with rectangular bus.
4. Filler panels shall be used where the service section exceeds the meter panel width. Meter panels, either socket or blank, shall not be hinged to hinged filler panels. Non-hinged filler panels shall not extend into the required instrument transformer compartment access opening.
5. The grounding connection shall be made in the main switch or breaker compartment.
6. Meter panels shall be constructed of 12 gauge (minimum) steel and shall be reversible, sealable, hinged, and interchangeable. See EUSERC Drawing 332 for socket meter panel details.
7. Hinges shall be readily interchangeable, left or right, on the job site.

(Notes continue on next page)

1101.1 LOW-PROFILE SWITCHBOARD SERVICE SECTION (Continued)

8. Width of meter panels may in some cases require the service section to be wider than the minimum allowable width of the instrument transformer compartment.
9. Meter panels shall be equipped with stops to prevent inward swinging beyond the front surface of the service section.
10. For requirements regarding instrument transformer compartments, see:
 - 0 to 1000 amperes, see EUSERC Dwgs. 319, 320
 - 1001 to 3000 amperes, see EUSERC Dwg. 322
11. Switchboards 400 amps and above shall be provided with landing lugs in the cable pull section.
12. Dimension may be reduced if the service section is supplied from horizontal cross-bussing.



OBSOLETE - FOR MAINTENANCE ONLY

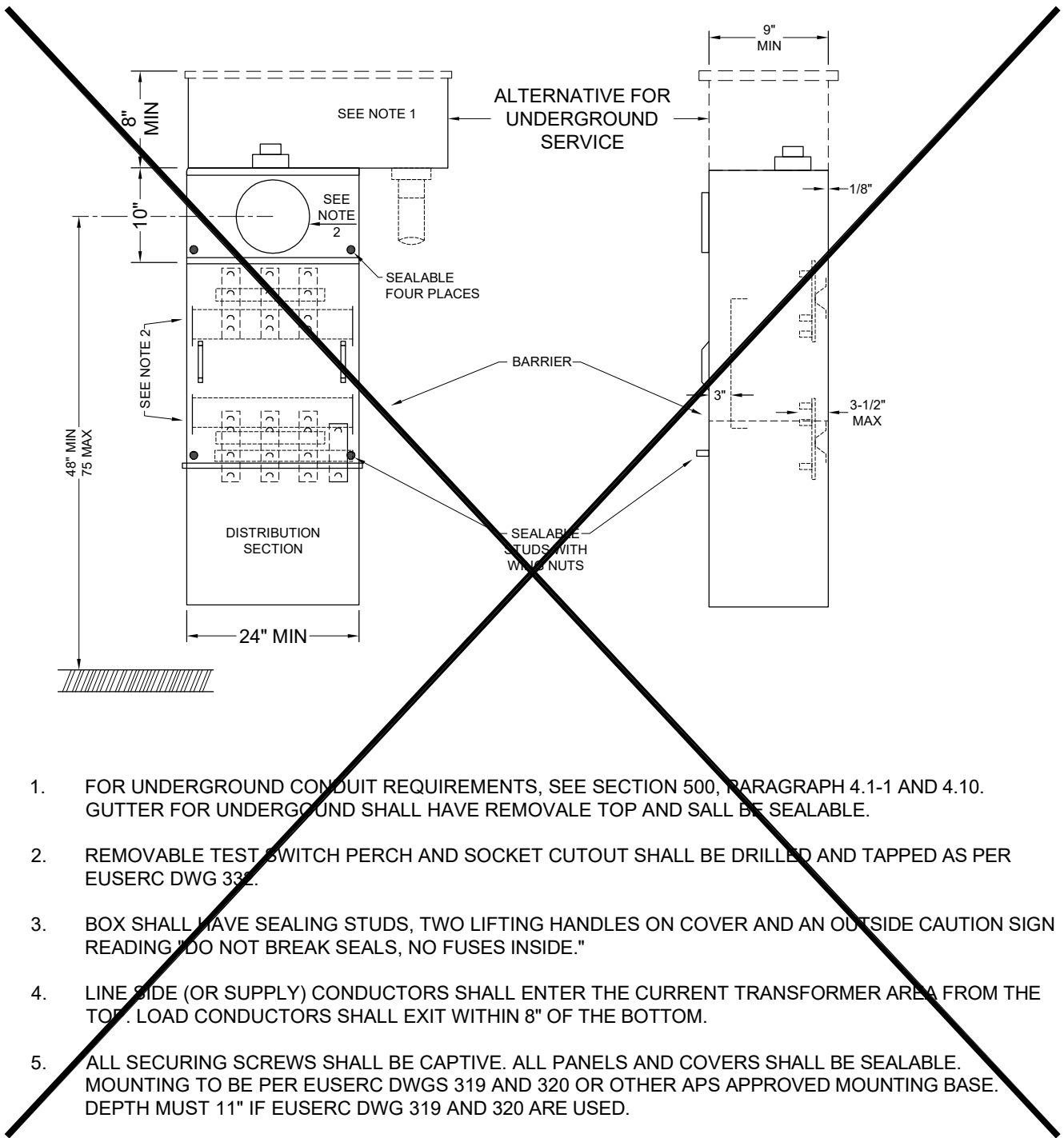

1. FOR UNDERGROUND CONDUIT REQUIREMENTS, SEE SECTION 500, PARAGRAPH 4.1-1 AND 4.10. GUTTER FOR UNDERGROUND SHALL HAVE REMOVABLE TOP AND SHALL BE SEALABLE.
2. REMOVABLE TEST SWITCH PERCH AND SOCKET CUTOUT SHALL BE DRILLED AND TAPPED AS PER EUSERC DWG 332.
3. BOX SHALL HAVE SEALING STUDS, TWO LIFTING HANDLES ON COVER AND AN OUTSIDE CAUTION SIGN READING "DO NOT BREAK SEALS, NO FUSES INSIDE."
4. LINE SIDE (OR SUPPLY) CONDUCTORS SHALL ENTER THE CURRENT TRANSFORMER AREA FROM THE TOP. LOAD CONDUCTORS SHALL EXIT WITHIN 8" OF THE BOTTOM.
5. ALL SECURING SCREWS SHALL BE CAPTIVE. ALL PANELS AND COVERS SHALL BE SEALABLE. MOUNTING TO BE PER EUSERC DWGS 319 AND 320 OR OTHER APS APPROVED MOUNTING BASE. DEPTH MUST BE 11" IF EUSERC DWG 319 AND 320 ARE USED.

1101.3 COMBINATION INSTRUMENT TRANSFORMER AND METER BOX 0 - 600 VOLTS, 400 - 600 AMP

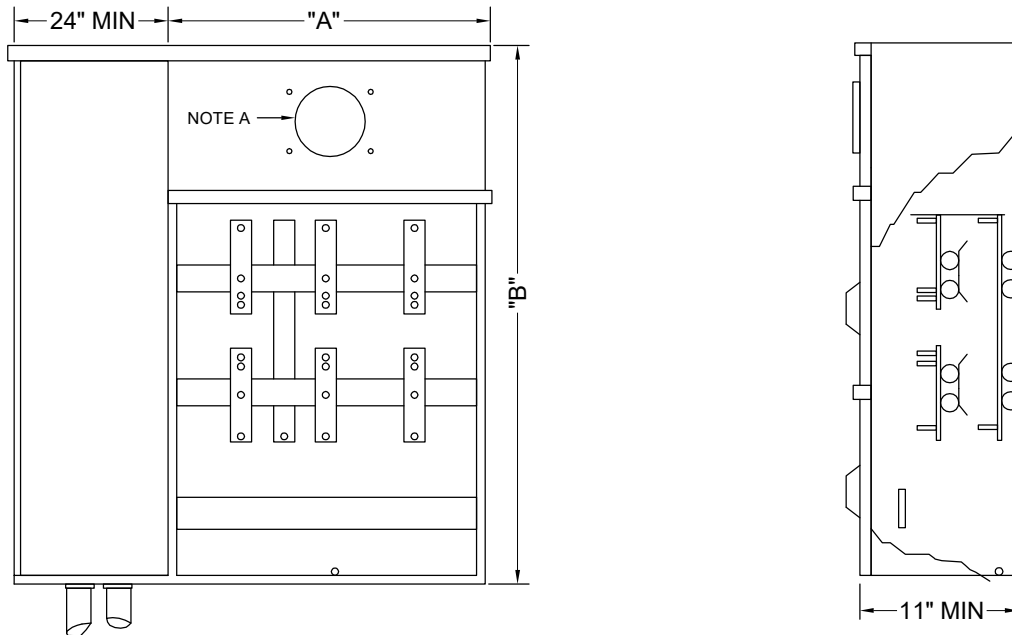

DIMENSIONS	3Ø 4W	1Ø 3W
"A"	36"	3Ø
"B"	54"	48"

1. FOR UNDERGROUND CONDUIT REQUIREMENTS, SEE SECTION 500.
2. ALL PANELS AND COVERS SHALL BE SEALABLE. SEALING PROVISIONS SHALL CONSIST OF TWO DRILLED STUD AND WING NUT ASSEMBLIES ON OPPOSITE SIDES OF EACH PANEL.
3. COVERS SHALL BE PROVIDED WITH TWO LIFTING HANDLES AND BE LIMITED TO A MAXIMUM SIZE OF 9 SQUARE FEET IN AREA.
4. REMOVALBLE TEST SWITCH PERCH AND METER SOCKET CUTOUT TO BE DRILLED AND TAPPED PER EUSERC DWG. 332.
5. C.T. MOUNTING TO BE PER EUSERC DWG. 319 OR 320.

1102.0 EUSERC DRAWINGS - LOW-VOLTAGE SERVICE EQUIPMENT

1102.1 SWITCHBOARD SERVICE SECTION ILLUSTRATIONS

The following pages are inserted to illustrate the appearance of standard switchboard service sections.

The drawings on these pages are basically EUSERC drawings and show only sections as they would be used with overhead service entrance conductors. Pull sections would be added along-side for underground service entrance conductors, and additional distribution feeder sections would be added as needed to supply a particular Customer's electrical load.

1102.2 APS ADDENDUMS TO EUSERC DRAWINGS

Although most EUSERC drawings are accepted by APS "as is", some of the drawings are not. APS has provided an Addendum page for each drawing that it does not accept "as is".

This Addendum will immediately follow the EUSERC page in this manual, and will explain any required changes and/or additions APS requires. **These changes are mandatory, and APS will not accept any equipment in violation of these addendums.**

METERING AND SERVICE EQUIPMENT (0-600V)

I. SCOPE

- A. This section contains minimum manufacturing requirements for utility metering and service equipment rated 0-600V.
- B. The following general notes apply to all drawings in this section where applicable. Each drawing may also contain additional notes which should be considered unique to that drawing unless reference is made to another specific drawing or section.
- C. Refer to Section 200 for specific utility requirements and utility acceptability of these requirements.
- D. Refer to the *installation guide* section for typical application and installation requirements.

II. METERING EQUIPMENT REQUIREMENTS, GENERAL

These Requirements are based on practices that are necessary to supply uniform satisfactory and safe service. Interpretations or clarifications of intent of these Requirements are subject to EUSERC approval. Installations shall also conform to the provisions of applicable codes and ordinances of local inspection authorities and the servicing agency.

A. Grounding, General

1. Lugs for terminating the customer's ground wire (or other grounding conductors) shall be located outside of the sealable section and shall be designed to readily permit the customer's neutral system to be isolated, when necessary, from the serving agency.
2. Ground buss, when provided, shall be located at the rear of underground terminating enclosures (i.e. pull boxes and pull sections).

B. Meter Sequence

The metering arrangement, approved as the standard and required by all the serving agencies, provides for the line current to enter the meter first and then the disconnecting means and overload protective devices (meter-switch-fuse sequence). For multiple meter installations, refer to local codes.

RE	CHANGE	BY	DSGN	APPV	DATE	REV	CHANGE	BY	DSGN	APPV	DATE		
A						D							
B						E							
C						F							
SHEET 1 OF 19		Indicates Latest Revision		<input checked="" type="checkbox"/> Completely Revised		New Page		Information Removed		SECTION 300			
		EUSERC MANUAL											
		METERING & SERVICING EQUIPMENT											

C. Meter Access

Customer locking for meter enclosures shall provide for independent access by the serving agency.

D. Meter Heights

Meters shall be located not more than 75 inches and not less than 48 inches above the ground or standing surface when installed outdoors. When meters are enclosed in a cabinet or indoors in a meter room, the minimum height may be reduced to 36 inches. The meter height shall be measured to the meter axis. Exception: Utilities in snow areas may require increased height.

E. Meter Sockets, General

1. See Section 200 for tabulation of meter socket requirements of member utilities.
2. The socket and enclosure shall be designed in accordance with the latest revision of AEIC-EEI-NEMA Standards for Watthour Meter Sockets, Publication ANSI C12.7, and Underwriters Laboratories Standard for Meter Sockets UL414. Socket rim to jaw clearance shall be no less than ANSI C12.7 (0.500") or more than (0.690").

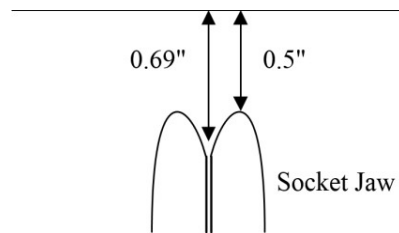

Exception: The 0.690" dimension does not apply to transformer rated sockets and ground and neutral clips on self-contained sockets.

3. Meter sockets provided for self-contained meters shall be rated as follows:
 - a. For residential service applications, meter sockets shall have a maximum ampacity rating not less than the ampacity rating of the associated service disconnect. The maximum ampacity rating is 125% of the continuous-duty rating.
 - b. For commercial and industrial service applications, meter sockets shall have a continuous-duty rating of 100 amperes for service disconnects rated up to 125 amperes (maximum) and a continuous-duty rating of 200 amperes for service disconnects rated up to 250 amperes (maximum)

RE	CHANGE	BY	DSGN	APPV	DATE	REV	CHANGE	BY	DSGN	APPV	DATE
A						D					
B						E					
C						F					

<input type="checkbox"/>	Indicates Latest Revision	<input checked="" type="checkbox"/>	Completely Revised	<input type="checkbox"/>	New Page	<input type="checkbox"/>	Information Removed
--------------------------	---------------------------	-------------------------------------	--------------------	--------------------------	----------	--------------------------	---------------------

SHEET
2 OF 19

EUSERC MANUAL
**METERING & SERVICING
EQUIPMENT**

SECTION
300

4. Sockets for self-contained meters shall be furnished, installed and wired by the customer. Diagrams of connections are shown on Drawing G-1 of the installation guides.
5. When self-contained meter sockets are installed in switchboards, they are to be wired by the switchboard manufacturer. Consult the Utility for use of lever bypass meter sockets.
6. Sockets for instrument transformer installations shall be furnished and installed by the customer. The serving agency will furnish and install the normal secondary wiring from the instrument transformers to the meter socket.
7. Potential taps, including the neutral potential tap, shall be located behind a sealed panel. The customer's grounding electrode connection shall not be located within the meter socket or socket area of a combination CT / meter enclosure.
8. Ring-type sockets shall be furnished with sealing rings. Consult the Utility for usage of ring less sockets.
9. Instrument-rated meter sockets installed on:
 - a. Hinged panels shall be fabricated and installed by the manufacturer for back connection. (See Drawings 332 and 333)

Note: Screws used to mount cast meter sockets to hinged panels shall provide a 1/8" minimum clearance between the screw head and the back of the meter socket ring.
 - b. Non-hinged panels shall be fabricated and installed by the manufacturer for front connection. (See Drawings 313, 314 & 339)

Note: Meter sockets shall be attached with machine screws so that they maybe interchanged or replaced. Sheet metal and self-tapping screws are not acceptable.
10. Instrument-rated meter sockets installed on:

RE	CHANGE	BY	DSGN	APPV	DATE	REV	CHANGE	BY	DSGN	APPV	DATE
A						D					
B						E					
C						F					

SHEET 3 OF 19		Indicates Latest Revision	X	Completely Revised	New Page	Information Removed	
EUSERC MANUAL							
METERING & SERVICING EQUIPMENT							
SECTION 300							

- a. Hinged panels shall be fabricated and installed by the manufacturer for back connection. (See Drawings 332 and 333)

Note: Screws used to mount cast meter sockets to hinged panels shall provide a 1/8" minimum clearance between the screw head and the back of the meter socket ring.

- b. Non-hinged panels shall be fabricated and installed by the manufacturer for front connection. (See Drawings 313, 314 & 339)

Note: Meter sockets shall be attached with machine screws so that they maybe interchanged or replaced. Sheet metal and self-tapping screws are not acceptable.

- 11. All self-contained meter sockets shall be rigidly attached to the backwall of the socket enclosure or to a stationary support connected to the enclosure. For ring-type meter panels, the meter sockets shall be attached to the meter panel to assure alignment of the socket ring to the socket jaws and prevent removal of the panel with the meter in place. Sheet metal or self-tapping screws are not acceptable.

F. Meter Sockets with Test-Bypass, Disconnect Facilities

- 1. Sockets equipped with test-bypass disconnect facilities are required for some installations and prohibited on others. For use in any locality, consult the serving agency.

G. Meter & Cover Panels, General

- 1. The hinged meter panels shown on Drawings 332 & 333 are designed to accommodate only transformer-rated socket meters. Self-contained sockets shall not be mounted on hinged panels.
- 2. The nonhinged meter panels shall not be used in front of a current transformer section. For a specially engineered switchboard, the nonhinged panel as shown on Drawing 336 will accommodate a socket-type meter when used with current transformers.
- 3. Not more than two meters shall be mounted on any removable meter panel.
- 4. Additional space may be required for recording or graphic demand meters (see Drawing 333).
- 5. Hinged meter and filler panels shall be equipped with stops to prevent inward swinging beyond the front surface of the switchboards.

RE	CHANGE	BY	DSGN	APPV	DATE	REV	CHANGE	BY	DSGN	APPV	DATE
A						D					
B						E					
C						F					

SHEET 4 OF 19	Indicates Latest Revision	<input checked="" type="checkbox"/> Completely Revised	<input type="checkbox"/> New Page	<input type="checkbox"/> Information Removed	SECTION 300
	EUSERC MANUAL				
	METERING & SERVICING EQUIPMENT				

6. A hinged instrument transformer cabinet cover may be used provided there is proper clearance to open the cover when the cabinet is installed. A cabinet with a hinged cover shall be designed so that the cover cannot be removed by tampering with the hinges when the cabinet cover is closed. Provisions shall be made for sealing the cabinet cover by use of approved method.

7. All pull and termination section cover panels shall be removable, sealable, provided with two lifting handles, and limited to a maximum size of nine square feet in area.

H. Lifting Handles

1. When lifting handles are required on panels and covers, each handle shall be sized for full hand grasping, securely attached, and have strength to withstand handling stresses of a minimum of 75 pounds.

Note: Chest type handles with a folding bale grasp are not acceptable.

I. Sealing

1. All cover panels, removable access panels, and hinged panels for compartments containing unmetered conductors shall be sealable. When a raceway or conduit for meter secondary wiring is necessary, the raceway or conduit shall be sealable. No removable panel or cover requiring sealing shall be located behind other panels, covers or doors (except raintight enclosure doors).

Note: Carriage bolts may be used to secure cover panels in place of sealing provisions when the bolts are installed at the factory and do not require field removal and installation to complete assembly of the switchboard sections.

2. Sealable latches, stud and wing-nuts, or sealing screws shall be provided as the means of sealing removable or hinged access covers.

3. Hinged cover panels shall be sealed on the side opposite the hinges.

4. Removable cover panels shall be sealed with stud and wing-nut assemblies on opposite sides of the cover. Alternate sealing methods may be used if the removable covers are self-supporting with the captive screws and sealing provisions removed.

RE	CHANGE	BY	DSGN	APPV	DATE	REV	CHANGE	BY	DSGN	APPV	DATE
A						D					
B						E					
C						F					

SHEET 5 OF 19	Indicates Latest Revision	<input checked="" type="checkbox"/> Completely Revised	<input type="checkbox"/> New Page	<input type="checkbox"/> Information Removed
	EUSERC MANUAL			
	METERING & SERVICING EQUIPMENT			
SECTION 300				

5. Sealing and securing devices shall be provided as follows:
 - a. Stud and wing-nut assemblies shall consist of a ¼ inch X 20 (minimum) stud and an associated wing-nut, each drilled .0635 inches (minimum) for sealing purposes. The stud shall be securely attached to not loosen or screw out when being fastened.
 - b. Sealing screws shall be drilled .0635 inches (minimum) for sealing purposes.
 - c. Latching devices shall be designed to permit positive locking and be made of a durable corrosion resistant material.

J. Cover Panel Labeling

Test-bypass block compartment cover panels shall have a caution sign on the front reading

“Do Not Break Seal – No Fuses Inside.”

K. Unmetered Conductors

Customer unmetered service wires and metered load wires are not to be run in the same conduit, raceway or wiring gutter. Metered and unmetered wires shall be separated by suitable barriers. Metered wires from the customer's distribution section (branch circuits) shall not pass through sealable sections. For exceptions, see Apartment Metering.

L. Buss Bars

1. Ampacity

- a. The dimensions in these requirements are based on the use of rectangular bus bar. Ampacities of buss bar conductors shall be based on UL-891. Standard for Dead-Front Switchboard, including ampacities based on thermal limits provided for therein. Maximum widths and number of bus bars shall conform to EUSERC requirements.
- b. Ampacity of instrument transformer compartments bus shall conform to NEMA Standards Publication PB2, Part 6.04, Paragraph A, for Section Bus.

2. Plating

- a. Buss bars shall be plated to prevent corrosion.

RE	CHANGE	BY	DSGN	APPV	DATE	REV	CHANGE	BY	DSGN	APPV	DATE
A						D					
B						E					
C						F					

SHEET 6 OF 19	Indicates Latest Revision	<input checked="" type="checkbox"/> Completely Revised	<input type="checkbox"/> New Page	<input type="checkbox"/> Information Removed
	EUSERC MANUAL			
	METERING & SERVICING EQUIPMENT			
SECTION 300				

3. Attachment to the Enclosure

- a. Buss bars and other hardware attached to the outer walls of the enclosure shall be secured with devices that may not be loosened from the outside. Screws or bolts requiring special tools for installation or removal are not acceptable.

M. Service Disconnects

1. Meter Disconnects, General

- a. For each meter, the customer shall furnish and install a circuit breaker, fused switch, or other approved disconnecting means with over-current protection referred in these requirements as a meter disconnect.
- b. The meter disconnect shall control all the energy registered by its related meter.
- c. Where permitted by the serving agency, the meter disconnect may consist of up to six separate devices.

2. Meter Disconnects, Locking Provisions

- a. Meter disconnects supplied from instrument-transformer compartments shall be capable of being locked in the open off position.
- b. Locking provisions may be:
 - (1) A lockout device which is incorporated as an integral part of each meter disconnect
 - (2) A lockable cover for each meter disconnect where the lock prevents the operation of the disconnect and prevents removal of the cover
 - (3) A lockable cover for multiple meter disconnects where the lock prevents the operation of any of the disconnects, prevents removal of the cover, and all disconnects are supplied from a single instrument transformer compartment.
 - (4) Items 1, 2, and 3 shall be permitted to be accomplished by a maximum of two (2) locking provisions per disconnect.
 - (5) For fused disconnects, the fuse access cover shall be lockable when the disconnect is in the off (open) position.

RE	CHANGE	BY	DSGN	APPV	DATE	REV	CHANGE	BY	DSGN	APPV	DATE
A						D					
B						E					
C						F					

<p>SHEET 7 OF 19</p>	Indicates Latest Revision	<input checked="" type="checkbox"/> Completely Revised	<input type="checkbox"/> New Page	<input type="checkbox"/> Information Removed	<p>SECTION 300</p>
	<p>EUSERC MANUAL</p>				
	<p>METERING & SERVICING EQUIPMENT</p>				

(6) All locking provisions for disconnects rated less than 400 amperes shall accept a lock shank of not less than 1/4 inch.

(7) All locking provisions for disconnects rated 400 amperes and above shall accept a lock shank of not less than 5/16 inch.

3. Main Service Disconnects

- a. A main service disconnect device is installed on the supply (line) side of a group of meter sockets and may be a circuit breaker, fused disconnect, or other approved disconnecting means.
- b. A service disconnect shall be installed on the supply (line) side of more than six-meter sockets.
- c. A service disconnect may be permitted on the supply side of two to six-meter sockets. Consult the serving agency for specific requirements.
- d. A service disconnect is not permitted on the supply (line) side of a single meter socket. (Old Sequence).
- e. The cover on a line side disconnect shall be sealable, (see Drawing 315 Note 5).

N. Utility Compartment Labeling

Manufacturers shall provide information and safety labels in utility compartments as follows:

- 1. Caution labels for switchboard pull sections shall be provided on the safety barrier and cover of each pull section where energized buss is less than 4 inches from removable access cover panels. See Drawing 347 for additional requirements.
- 2. Torque labels shall be provided in each utility compartment where nut and bolt assemblies using cone-type (Belleville) washers are used for utility terminations, test-bypass block circuit closing nuts, or for securing current transformers or current transformer buss removable links. Labels shall be readily visible and shall not be installed on any removable or hinged cover panel.

RE	CHANGE	BY	DSGN	APPV	DATE	REV	CHANGE	BY	DSGN	APPV	DATE
A						D					
B						E					
C						F					

<p>SHEET 8 OF 19</p>	Indicates Latest Revision	<input checked="" type="checkbox"/> Completely Revised	<input type="checkbox"/> New Page	<input type="checkbox"/> Information Removed	<p>SECTION 300</p>
	EUSERC MANUAL				
	METERING & SERVICING EQUIPMENT				

III. SELF-CONTAINED RATED METERING INSTALLATION

Self-contained meters are designed to carry rated current and be energized at line potential. They do not require auxiliary instrument transformers to step down line current or voltage.

A. Residential, General

Four Types of self-contained meters are commonly used for this application.

1. Class 100 socket-type meter
2. Class 200 socket-type meter
3. Class 320 socket-type meter
4. Class 400 bolt-in type meter

*(See Section 200 for specific utility requirements)
Note: Automatic socket bypass devices are not allowed.*

B. Commercial, General

Class 100 or 200 socket-type meters are commonly used; and test-bypass disconnect facilities are required for this application. Some utilities allow Class 320 or Class 400-amp meters for specialized installations (Go to euserc.org for specific utility requirements).

C. Multiple, Switchboard

1. The socket and socket enclosure shall be designed in accordance with the latest revision of AEIC-EEI-NEMA Standards for Watthour Meter Sockets, Publication ANSI C12.7, and with Standard for Meter Sockets UL414.
2. The bussing or cables to each individual meter socket are to be installed so they can be visibly traced.
3. Multiple Meter enclosures that are not factory bussed shall have non-removable, solid metal barriers to isolate the metered conductors from the un-metered conductors.
4. The service termination enclosure, socket enclosures, raceways and sections for test-bypass or manual circuit closing facilities shall have separate, removable and sealable access panels (or plates). Meter socket enclosures shall have a separate sealable cover containing no more than two-meter positions.

RE	CHANGE	BY	DSGN	APPV	DATE	REV	CHANGE	BY	DSGN	APPV	DATE
A						D					
B						E					
C						F					

SHEET 9 OF 19	Indicates Latest Revision	<input checked="" type="checkbox"/> Completely Revised	<input type="checkbox"/> New Page	<input type="checkbox"/> Information Removed
	EUSERC MANUAL			
	METERING & SERVICING EQUIPMENT			
SECTION 300				

D. Meter Spacing and Clearances

1. The rules for spacing of socket meters in multiple residential meter installations shall be as follows:
 Horizontal spacing - 7 1/2 inches minimum on centers.
 Vertical spacing - 8 1/2 inches minimum on centers.
2. See Drawing 353 for Multiple Meter clearances.

E. Apartment Metering Excluding Switchboards

1. Where many apartments in one building are to be individually metered; a combination of service termination, raceway and meter enclosures may be used.
(Consult local utility for approval.)
2. When these units are constructed with metered and un-metered conductors in the same raceway behind adjacent meter sockets, the serving agency will require the following additional specifications.
 - a. Metered and un-metered conductors shall be separated so that all the load is being metered (Line and Load conductors not cabled together).
 - b. Factory "harness-style" wiring (or equivalent) shall be used between the line wire and line terminals of each meter socket, between the load terminals of each meter socket, and the line side of the corresponding circuit breaker.
 - c. Connecting wires between meter socket load terminals and circuit breaker line terminals shall be separately cabled for each position in the row.
 - d. When the installation is completed, all panels must be removable for inspection of wiring.
 - e. Panel design shall permit convenient replacement of any individual meter socket.
3. See installation guides for typical arrangements.

RE	CHANGE	BY	DSGN	APPV	DATE	REV	CHANGE	BY	DSGN	APPV	DATE
A						D					
B						E					
C						F					

SHEET 10 OF 19	Indicates Latest Revision	<input checked="" type="checkbox"/> Completely Revised	<input type="checkbox"/> New Page	<input type="checkbox"/> Information Removed
	EUSERC MANUAL			
	METERING & SERVICING EQUIPMENT			
				SECTION 300

IV. TRANSFORMER RATED METERING INSTALLATIONS

A. General Requirements

1. Instrument transformer compartments are generally required when the connected load exceeds 200 amperes. See Section 200 for exceptions and utility acceptability of these requirements and Section 400 when the voltage between conductors exceeds 600 volts.
2. Meter, instrument transformers and test switches will normally be furnished and installed by the serving agency. Any required conduits or raceways shall be furnished and installed by the switchboard manufacturer or contractor,
(See Section 200 for specific utility requirements).
3. All compartments containing unmetred conductors shall be sealable. When a raceway or conduit for meter secondary wiring is necessary, such raceway or conduit shall be sealable.

B. Switchboard Service Sections, General

1. For both standard and specially engineered switchboard service sections, all service or supply conductors shall enter the service section through one end and leave through the opposite end of the instrument transformer compartment. This stipulation applies to either overhead or underground service or if two or more service sections are connected. The direction of feed shall be vertical through the instrument transformer compartment, (See Drawing 345).
2. When more than one switchboard service section is installed, each service section shall be completely barriered from other service sections, pull sections, or service switches or disconnects. Barriers may have an opening to allow passage of unmetred conductors between sections. Barriers shall be constructed from 16-gauge (minimum) steel in accordance with (B)(3) below.

Note 1: A portion of the barrier between sealed utility metering sections and the pull section may be 1/8" minimum glastic or equivalent due to potential electrical clearance issues.

RE	CHANGE	BY	DSGN	APPV	DATE	REV	CHANGE	BY	DSGN	APPV	DATE
A						D					
B						E					
C						F					

SHEET 11 OF 19	Indicates Latest Revision	<input checked="" type="checkbox"/> Completely Revised	<input type="checkbox"/> New Page	<input type="checkbox"/> Information Removed
	EUSERC MANUAL			
	METERING & SERVICING EQUIPMENT			
				SECTION 300

Note 2: The clearance between bus bar and steel or glastic shall be a maximum of 3". The maximum clearance shall be measured in accordance with Fig. 1. No barrier shall be required between individual phases and neutral.

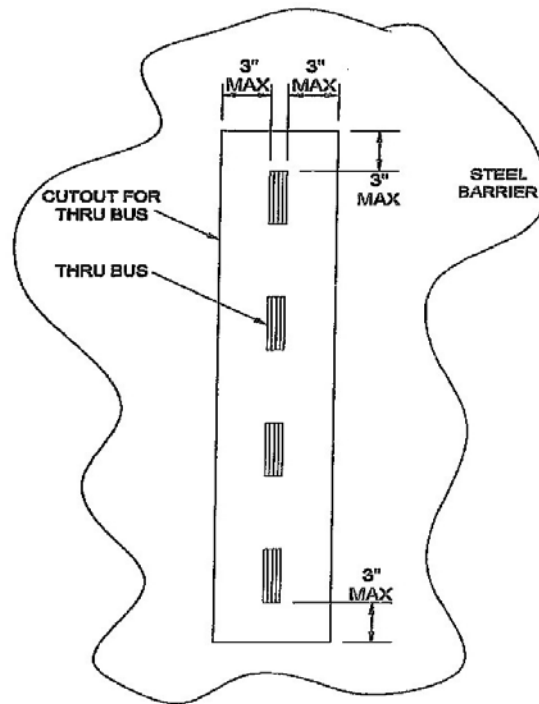

Fig. 1

3. Except where otherwise specified in these requirements, barriers used in switchboard installations to separate customer sections from utility sections (i.e., pull sections and metering sections) and sections containing un-metered conductors or buss shall be constructed from 16-gauge (minimum) steel and shall be secured with devices that are not removable from either the customer sections or the exterior of the switchboard.
4. When two or more switchboard service sections are supplied from one set of service conductors, the supply conductors are to be arranged so they are readily accessible without disturbing the instrument transformers and associated secondary wiring.
5. Additional service connections may be made in the main service termination and pull section where more than one metering installation is necessary or where more than one rate schedule is desired. Additional service connections shall not be made in the instrument transformer compartment. Consult serving agency for approval.

RE	CHANGE	BY	DSGN	APPV	DATE	REV	CHANGE	BY	DSGN	APPV	DATE
A						D					
B						E					
C						F					

SHEET 12 OF 19	Indicates Latest Revision	<input checked="" type="checkbox"/> Completely Revised	<input type="checkbox"/> New Page	<input type="checkbox"/> Information Removed
	EUSERC MANUAL			
	METERING & SERVICING EQUIPMENT			
SECTION 300				

6. Meter installations of six meters or less shall be connected "new sequence". Consult serving agency for exceptions.

C. Standard Switchboard Service Section

1. The general arrangement of a standard switchboard section is shown on Drawings 325 and 326.
2. A standard switchboard service section has a hinged meter panel located in front of the instrument transformer compartment. Drawing 333 shows spacings for various combinations of multiple meters.
3. Hinged meter panels must have handles and open a minimum of 90 degrees with meters and test switches mounted to permit safe and ready access to the instrument transformers. When hinged panels are recessed, the section shall have additional width to meet this requirement. A recessed panel requires utility approval as a specially engineered section, (See Drawing 354).
4. Hinged meter panels must be sealable and easily removable with the hinges readily interchangeable from the right or left side on the job site.
5. The hinged meter panels on Drawings 332 and 333 are designed for transformer-rated, socket-type meters.
6. Meter panels and filler panels shall be equipped with stops to prevent inward swinging beyond the front surface of the switchboard.
7. Not more than two meters shall be mounted on any removable meter panel.
8. For hinged socket meter panels, see Drawings 332 and 333.
9. For underground service application Of Standard Switchboard Service Sections, see Drawing 345

D. Specially Engineered Service Sections

1. Switchboards which do not conform to standard design criteria are considered specially engineered and include installations:
 - a. Rated over 3000 amperes or 600 volts.
 - b. Where the service breaker ampacity rating exceeds that of the standard service section.
 - c. Where multiple metering sections are used.

RE	CHANGE	BY	DSGN	APPV	DATE	REV	CHANGE	BY	DSGN	APPV	DATE
A						D					
B						E					
C						F					

SHEET 13 OF 19	Indicates Latest Revision	<input checked="" type="checkbox"/> Completely Revised	<input type="checkbox"/> New Page	<input type="checkbox"/> Information Removed	SECTION 300
	EUSERC MANUAL				
	METERING & SERVICING EQUIPMENT				

d. Where recessed meter panels are used.

E. Specially Engineered Service Sections

1. Switchboards which do not conform to standard design criteria are considered specially engineered and include installations:
 - a. Rated over 3000 amperes or 600 volts.
 - b. Where the service breaker ampacity rating exceeds that of the standard service section.
 - c. Where multiple metering sections are used.
 - d. Where recessed meter panels are used.

2. When a specially engineered service section is necessary, drawings in triplicate of the proposed section shall be submitted to the serving agency for approval prior to manufacture and bidding. Such drawings shall indicate the contractor's and the customer's name, address and job location.

3. The general arrangement of Specially Engineered Switchboard Service Sections should follow, as nearly as practicable, the Standard Switchboard Service Sections and the following general requirements shall be observed:
 - a. Instrument transformer-rated socket meters, used with current transformers, are normally mounted on hinged panels.
 - b. If a hinged meter panel is located behind a door, a clear space of at least 11 inches between the meter panel and the door is required and shall be designed to open 90 degrees with meters and test switches in place. If needed, additional section width shall be provided to meet this requirement.
 - c. A clear space behind a meter panel shall be provided for the secondary wiring and phase shifting device. For minimum dimensions between the hinged meter panel and the nearest buss, see Drawings 319-324.
 - d. For nonhinged meter panels, a clear space of four inches minimum to any barrier or obstruction shall be provided.
 - e. The nonhinged meter panels shall not be used in front of a current transformer section. For a specially engineered switchboard, nonhinged panels will accommodate socket-type instrument transformer-rated meters.

RE	CHANGE	BY	DSGN	APPV	DATE	REV	CHANGE	BY	DSGN	APPV	DATE
A						D					
B						E					
C						F					

SHEET 14 OF 19	Indicates Latest Revision	<input checked="" type="checkbox"/> Completely Revised	<input type="checkbox"/> New Page	<input type="checkbox"/> Information Removed
	EUSERC MANUAL			
	METERING & SERVICING EQUIPMENT			
SECTION 300				

- f. For minimum clearance between meters, (see Drawings 306, 333, 336, and 353).
- g. Additional panel space is required for recording or graphic demand meters, (see Drawing 333).
- h. Not more than two meters shall be mounted on any removable meter panel.
- i. Busses shall be adequately supported in the metering transformer compartment to withstand the mechanical stresses of a short circuit. The buss supports shall not interfere with installation or removal of current transformers. Current transformers shall not be used to support the busses. The busses shall be entirely self-supporting.
- j. The busses and current transformer mountings shall be designed so that each of the current transformers may be withdrawn from its mounting position directly through the access panel without disturbing any other current transformer. When multi-leaf busses are used, the busses shall be oriented so that they appear "edgewise" when viewed from the access panel.

F. Instrument-Transformer Compartments

- 1. For details of instrument transformer compartments, (see Drawings 319-322).
- 2. Covers for instrument transformer compartments shall be made of code gauge metal. If nonhinged panels are used as covers, they shall be provided with lifting handles and be attached with sealable studs and wing-nuts or by other approved means.
- 3. Copper or aluminum buss bars shall be used on both the line and load sides of all current transformers. When aluminum bus is used, the bus bars shall be plated, (See Bus Bar Plating, Drawing 300).
- 4. When the serving agency requests links and supports for through-type current transformer(s), the bus and removable links must be of a compatible material.
- 5. Instrument transformers supplied by the serving agency for metering shall not be utilized for any other purpose.
- 6. The ends of the current transformer buss stubs shall be located so the current transformers can be installed without removing adjacent panels.

RE	CHANGE	BY	DSGN	APPV	DATE	REV	CHANGE	BY	DSGN	APPV	DATE
A						D					
B						E					
C						F					

SHEET 15 OF 19	Indicates Latest Revision	<input checked="" type="checkbox"/> Completely Revised	<input type="checkbox"/> New Page	<input type="checkbox"/> Information Removed
	EUSERC MANUAL			
	METERING & SERVICING EQUIPMENT			
				SECTION 300

7. The current transformer bus stub supports in the instrument transformer compartment shall be sufficiently rigid to maintain alignment of the buss where the conductors are installed. The current transformers or bus links shall not provide buss support or alignment.
8. Except for factory-installed cross-bussing and conductors, either bus or cable, used to supply the instrument-transformer compartment, no other conductors or devices shall be installed in the instrument-transformer compartment or in the sealed area above the instrument-transformer compartment.

V. SERVICE TERMINATION EQUIPMENT, GENERAL

A. Switchboards Excluded

This paragraph of the Requirements applies to all meter and service equipment when not installed on switchboards.

1. General
 - a. Service termination facilities shall be specifically designed to receive the serving agency's underground service lateral conductors as a single cable entry. Enclosures designed for either overhead or underground cable entry are acceptable provided they meet requirements for both types of cable entry.
 - b. Service cable termination lugs or connectors shall be suitable for use with both aluminum and copper conductors. The serving agency should be consulted for specific lug or connector requirements.
 - c. Socket enclosures designed for single sockets rated up to, and including 200 amperes, shall have service terminating lugs independently mounted from the socket jaw support.
 - d. Test for meter sockets shall be in accordance with the current Standard for Meter Sockets UL414.
 - e. Service terminating space in enclosures rated greater than 200 amperes with multiple meter sockets shall accommodate either compression-type or screw-type mechanical landing lugs. All bussing or cable conductors beyond the terminating lugs shall be provided by the manufacturer or the customer's contractor. Bus stubs or bussing in the service terminating space used for terminating the utility service lateral shall have mounting bolts spaced in accordance with NEMA Standards. For termination buss detail, (see Drawing 343.)

RE	CHANGE	BY	DSGN	APPV	DATE	REV	CHANGE	BY	DSGN	APPV	DATE
A						D					
B						E					
C						F					

SHEET 16 OF 19	Indicates Latest Revision	<input checked="" type="checkbox"/> Completely Revised	<input type="checkbox"/> New Page	<input type="checkbox"/> Information Removed
	EUSERC MANUAL			
	METERING & SERVICING EQUIPMENT			
SECTION 300				

- f. The service cable termination compression or screw type mechanical lugs shall be compatible with the size and type of the service being installed (i.e., aluminum bodied AL-CU with aluminum cables, etc.). The termination lug landings for the neutral and each phase conductor shall be rigidly and permanently affixed in the service termination space and all grouped at one location.
- g. Wireways in the service termination space designed for terminating the utility service lateral shall be clearly identified for such use. Service termination shall be made in the service termination enclosure or in a specially designed space a meter panel which has a separate removable and sealable access plate.
- h. The layout or design of the service termination enclosure that requires bending the utility service conductors should provide space to permit a minimum cable bending radius equal to four times the overall diameter of the cable measured from the inner surface of the cable (from Minimum Bending Radius for Thermo-Plastic Insulated Cables, IPCEA S-61-402 and NEMA WC 5-1961 Standards).

NOTE: The overall termination enclosure size is not predicated solely on the cable bending radius. Adequate working space and electrical clearances are also considered in establishing enclosure dimensions in these requirements.

- i. The service termination enclosure, socket enclosure and test-bypass disconnect block section shall be sealable and isolated or barriered from other integral enclosure sections which are accessible to the customer to effectively prevent unauthorized connections to unmetered conductors or terminals.
- j. The manufacturer's rating label, or other markings used in lieu of a label, shall show among other things:
 - (1) The socket or socket enclosure is designed for overhead service entry, underground service entry, or both.
 - (2) The terminating lugs are designed for both aluminum and copper conductors.
 - (3) The wire size range of the terminating lugs.

2. Single Self-Contained Meter Termination, Underground Service

- a. The socket and enclosure shall be specifically designed to receive service cables from an underground supply system. Separate service terminating lugs supported independent of the socket and connected by buss bars are required for single family residential meter socket enclosures, (See Drawing 301).

RE	CHANGE	BY	DSGN	APPV	DATE	REV	CHANGE	BY	DSGN	APPV	DATE
A						D					
B						E					
C						F					

SHEET 17 OF 19	Indicates Latest Revision <input checked="" type="checkbox"/> Completely Revised	New Page	Information Removed
	EUSERC MANUAL		
	METERING & SERVICING EQUIPMENT		
			SECTION 300

- b. Wiring space for service lateral conductors shall be clearly identified as intended for such use. The wiring space shall be clear of all projections and shall be used exclusively for such purposes.
- c. A separate removable cover, independent of the meter panel, is required in front of the pull section, (See Drawing 301).
- d. Knockouts in cable wireways shall be positioned to minimize service lateral cable bending.
- e. The service cable entry and the meter socket section shall be sealable and isolated or barriered from other integral enclosure sections which are accessible to the customer to effectively prevent the attachment of unauthorized connections to unmetered conductors or terminals.
- f. The load wires from the distribution section (branch circuits) shall not pass through any sealable section.

3. Multiple Self-Contained Meter Termination, Underground Service

- a. When self-contained meters are installed on switchboards, the service termination requirements for switchboards shall be followed (see Switchboards).
- b. When self-contained meters are installed in multiple arrangements, in separate meter enclosures, the GENERAL service equipment requirements shall be followed. (See Drawing 343 for termination enclosure requirements and installation guide section for typical arrangements).

B. Switchboards

1. Switchboard Termination, Underground Service

- a. For underground services, the serving agency will terminate its service conductor on lug landings at the current transformer bus stubs only when the service is a single-meter installation and the switchboard is rated 400 amperes or less.

NOTE: Some utilities require the service conductors to be terminated in the pull section for switchboards rated less than 400 amperes.

- (i) The serving agency will terminate its service conductors on lug landings the pull section when the service is for multiple metering or the switchboard is rated 401 amperes or larger, (see Figure 1 on Drawing 345).

RE	CHANGE	BY	DSGN	APPV	DATE	REV	CHANGE	BY	DSGN	APPV	DATE
A						D					
B						E					
C						F					

SHEET 18 OF 19	Indicates Latest Revision	<input checked="" type="checkbox"/> Completely Revised	<input type="checkbox"/> New Page	<input type="checkbox"/> Information Removed
	EUSERC MANUAL			
	METERING & SERVICING EQUIPMENT			
				SECTION 300

- (a) On switchboards rated 401-800 amperes, the customer shall install conductors from the service termination lug landings to the line side of the current transformer compartment.
- (b) On switchboards rated 800 amperes or with multiple meters, bus bars shall extend from the service terminating lug landings into the current transformer compartment or the meter sockets.

2. Switchboard Termination, Overhead

For overhead services, the customer shall furnish lugs and connect the cable to line and load sides of the bus stubs in the current transformer compartment, (see Drawing 348).

RE	CHANGE	BY	DSGN	APPV	DATE	REV	CHANGE	BY	DSGN	APPV	DATE
A						D					
B						E					
C						F					

SHEET 19 OF 19	Indicates Latest Revision	<input checked="" type="checkbox"/> Completely Revised	<input type="checkbox"/> New Page	<input type="checkbox"/> Information Removed
	EUSERC MANUAL			
	METERING & SERVICING EQUIPMENT			
SECTION 300				

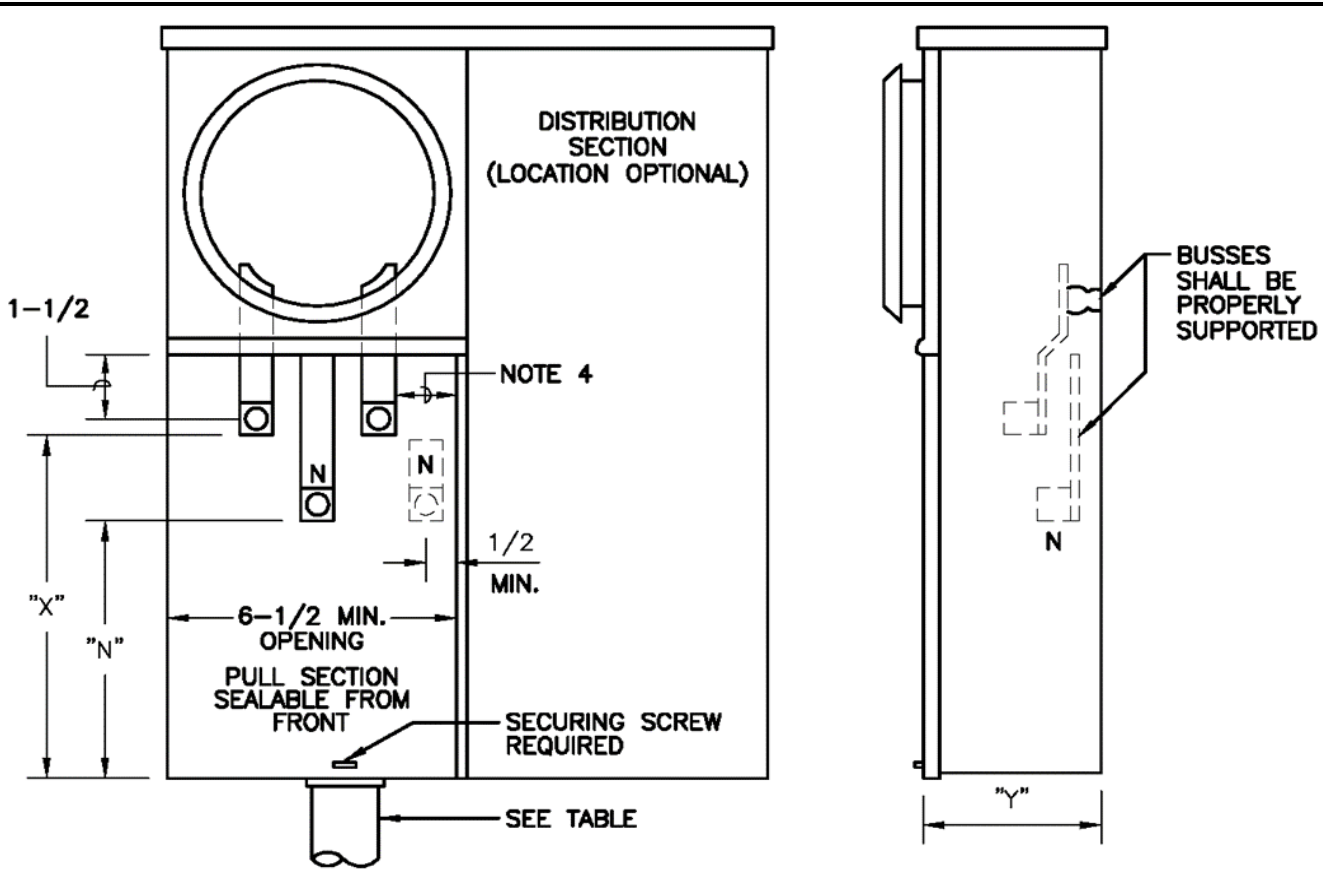

FRONT VIEW

SIDE VIEW

MAXIMUM AMPACITY	"X" MIN. DIM.	"N" MIN. DIM.	"Y" MIN. DIM.	CONDUIT RANGE
125	8"	6"	4"	1-1/4" TO 2-1/2"
225	11"	8-1/2"	5"	1-1/2" TO 3"

NOTES:

1. This equipment may be constructed for underground service supply or as a combination panel allowing either overhead or underground service supply applications.
2. Only one set of terminating facilities shall be provided and located as shown for both underground and overhead service supply applications. The terminating facilities for the service conductors shall be aluminum bodied mechanical lugs with a range of No. 6 through 1/0 AWG for the 125 ampere device and No. 4 AWG through 250 KCMIL for the 225 ampere device.
3. Provide a bonding screw or jumper if the neutral terminal is insulated from the enclosure.
4. A minimum radial clearance of 1-1/2 inches shall be provided between the hot bus terminals, hot bus and ground, and hot bus and neutral surfaces.

Exception: The clearance from the hot bus to the back of the enclosure may be reduced to 1-inch.

ALL DIMENSIONS SHOWN ARE IN INCHES

RE	CHANGE	BY	DSGN	APPV	DATE	REV	CHANGE	BY	DSGN	APPV	DATE
A						D					
B						E					
C						F					

SHEET 1 OF 1	<input type="checkbox"/> Indicates Latest Revision	<input checked="" type="checkbox"/> Completely Revised	<input type="checkbox"/> New Page	<input type="checkbox"/> Information Removed
	EUSERC MANUAL			
	RESIDENTIAL COMBINATION METER PANEL 225 AMPERES MAXIMUM 0-600 VOLTS			
SECTION 300 DRAWING 301				

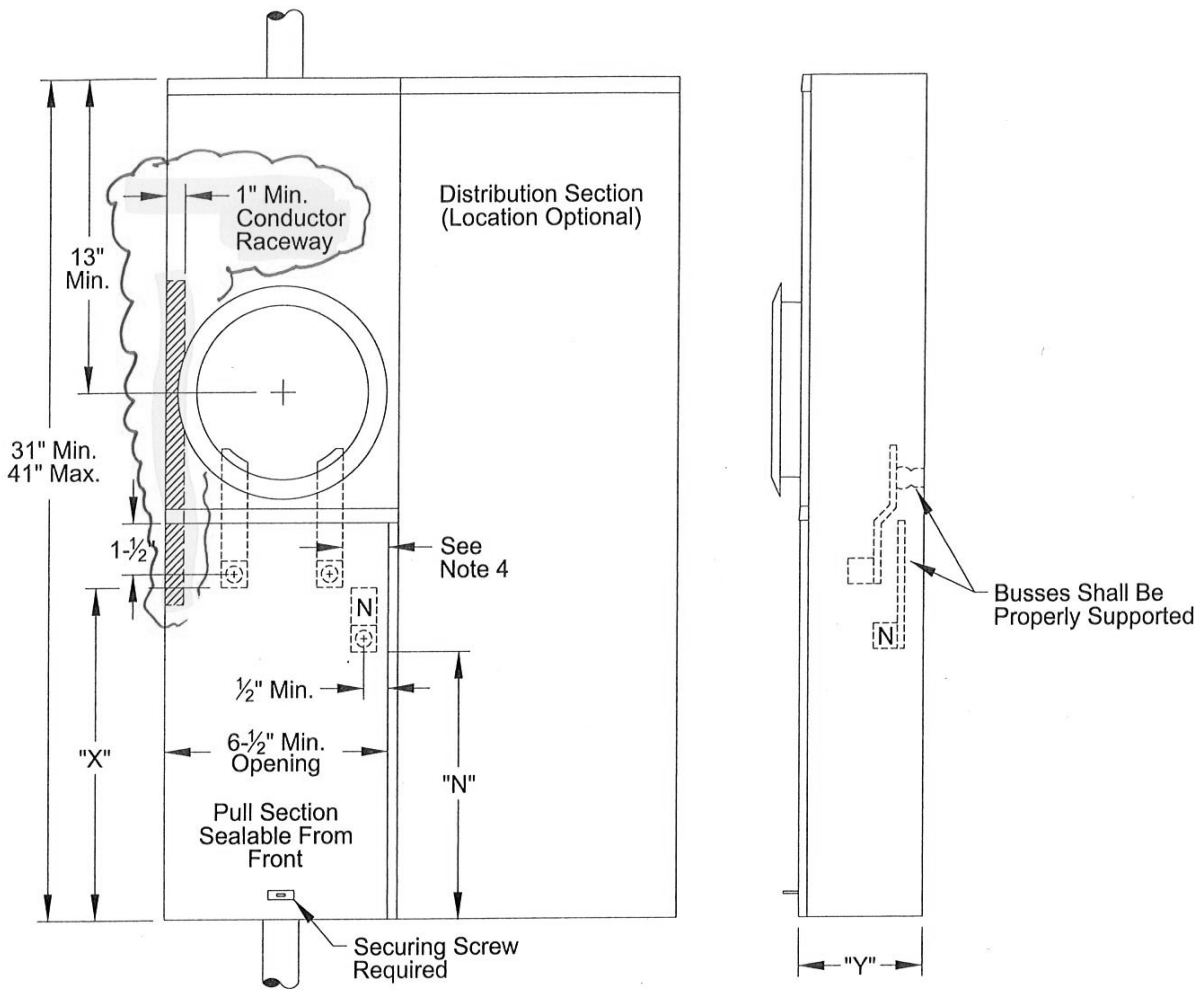

Maximum Ampacity	"X" Min. Dim.	"N" Min. Dim.	"Y" Min. Dim.	Conduit Range
125	-	-	-	1-1/4" to 2-1/2"
225	12"	9-1/2"	7"	1-1/2" to 4"

All Dimensions Shown Are In Inches

Notes:

1. This equipment may be constructed as a combination panel allowing either Overhead or underground service supply applications.
2. Only one set of terminating facilities shall be provided and placed on the bottom side, as shown, for both underground and overhead service supply applications. In overhead applications a dedicated wire way shall be provided to allow conductor to pass by meter socket jaws. The terminating facilities for the service conductors shall be aluminum bodied mechanical lugs with a range of NO.6 through 1/0 AWG for the 125 ampere device and No.4 AWG through 250 KCMIL for the 225 ampere device.
3. Provide a bonding screw or jumper if the neutral terminal is insulated from the enclosure.
4. A minimum radial clearance of 1-1/2 inches shall be provided between the hot bus terminals, hot bus and ground, and hot bus and neutral surfaces.

Exception: The clearance from the hot bus to the back of the enclosure may be reduced to 1 inch.

RE	CHANGE	BY	DSGN	APPV	DATE	REV	CHANGE	BY	DSGN	APPV	DATE
A					02/18	D					
B						E					
C						F					

SHEET 1 OF 1	<input type="checkbox"/> Indicates Latest Revision	<input checked="" type="checkbox"/> Completely Revised	<input type="checkbox"/> New Page	<input type="checkbox"/> Information Removed
	EUSERC MANUAL			
	RESIDENTIAL COMBINATION METER PANEL 225 AMPERES 0-600 VOLTS			

**SECTION
300
DRAWING
301B**

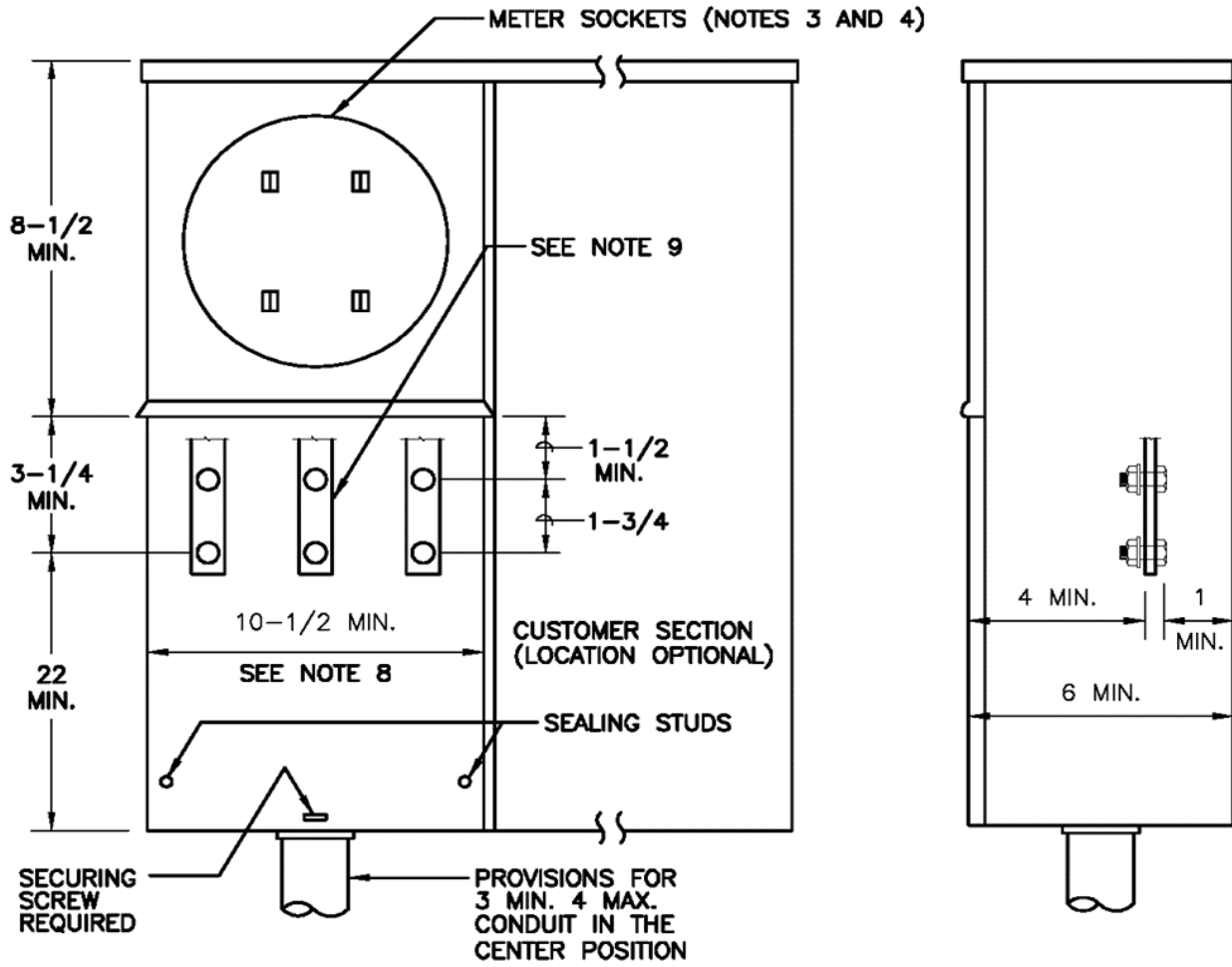

FRONT VIEW

SIDE VIEW

NOTES:

1. The panel shown is a combination device having both a utility section (i.e. pull section and metering section) and customer section, but may also be constructed without an attached customer section.
2. The panel shall be marked with either a rating of "320 amperes continuous" or "400 amperes maximum (320 amperes continuous)".
3. The meter panel shall be removable, sealable, and rainproof.

ALL DIMENSIONS SHOWN ARE IN INCHES

RE	CHANGE	BY	DSGN	APPV	DATE	REV	CHANGE	BY	DSGN	APPV	DATE
A						D					
B						E					
C						F					

SHEET 1 OF 2	Indicates Latest Revision	<input checked="" type="checkbox"/> Completely Revised	New Page	Information Removed	SECTION 300 DRAWING 302
	EUSERC MANUAL				
	RINGLESS METER PANEL FOR SINGLE FAMILY RESIDENTIAL UNDERGROUND SERVICE 400 AMPERE (CLASS 320), 120/240 VOLT, 1 PHASE, 3 WIRE				

4. The meter socket may be located above, to the left, or right of the terminating pull section.
5. Manual bypass facilities which maintain service continuity to the customer while the meter is removed for test or inspection shall be provided. Automatic bypasses are unacceptable. Bypass provisions which de-energize the meter socket are preferred but not required. Manufacturers shall submit proposed manual bypass methods to EUSERC Materials Committee for approval.
6. Manual bypass access panels shall be padlockable and sealable.
7. Pull section cover panels shall be removable, sealable, provided with two lifting handles, and limited to a maximum size of 9 square feet in area.
8. The access opening dimension shown is measured between the return flanges.
9. Cable terminating facilities shall consist of single-position studs with clearance and access requirements complying with Drawing 347.

Exception: The neutral clearance to the back wall of the enclosure may be reduced.

RE	CHANGE	BY	DSGN	APPV	DATE	REV	CHANGE	BY	DSGN	APPV	DATE
A						D					
B						E					
C						F					

SHEET 2 OF 2	Indicates Latest Revision	<input checked="" type="checkbox"/> Completely Revised	<input type="checkbox"/> New Page	<input type="checkbox"/> Information Removed	SECTION 300 DRAWING 302
	EUSERC MANUAL				
	RINGLESS METER PANEL FOR SINGLE FAMILY RESIDENTIAL UNDERGROUND SERVICE 400 AMPERE (CLASS 320), 120/240 VOLT, 1 PHASE, 3 WIRE				

**APS ADDENDUM TO EUSERC REQUIREMENTS
PAGE 302/APS**

NOTES:

1. Change note #1 to indicate that APS requires the main disconnect to be adjacent to, and in the same workspace as the meter.
2. Change note #3 to indicate that APS does not accept ringless style meter cans.
3. Change note #5 to indicate that APS does not accept any manual bypass meter sockets.



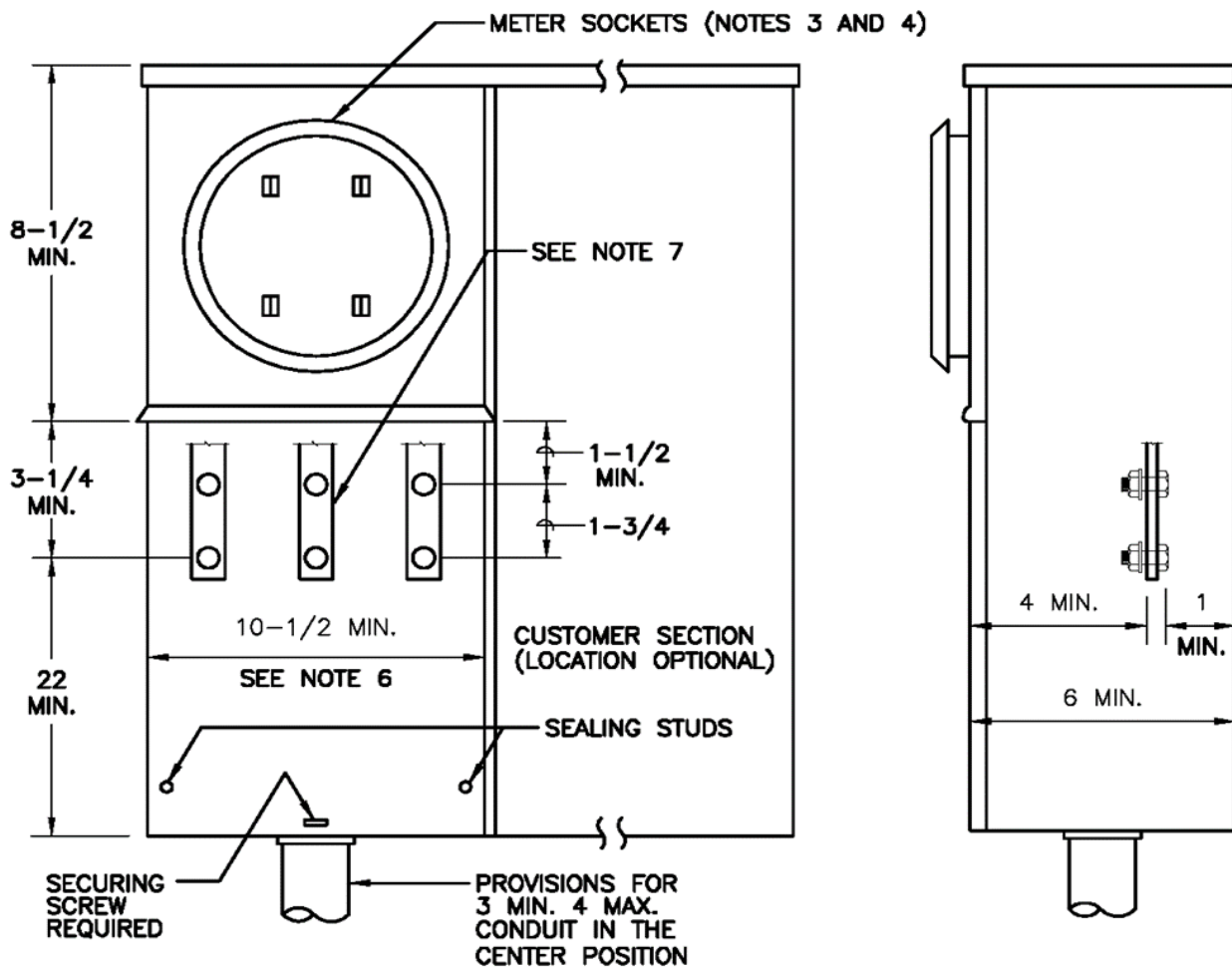

FRONT VIEW

SIDE VIEW

NOTES:

1. The panel shown is a combination device having both a utility section (i.e. pull section and metering section) and customer section, but may also be constructed without an attached customer section.
2. The panel shall be marked with either a rating of "320 amperes continuous" or "400 amperes maximum (320 amperes continuous)".
3. The panel shall be provided with a sealing ring and the meter socket shall be rigidly mounted on a support and attached to the meter panel.

ALL DIMENSIONS SHOWN ARE IN INCHES

RE	CHANGE	BY	DSGN	APPV	DATE	REV	CHANGE	BY	DSGN	APPV	DATE
A						D					
B						E					
C						F					

SHEET 1 OF 2	<input type="checkbox"/> Indicates Latest Revision	<input checked="" type="checkbox"/> Completely Revised	<input type="checkbox"/> New Page	<input type="checkbox"/> Information Removed
	EUSERC MANUAL			
	METER PANEL WITHOUT SOCKET BYPASS FACILITY RESIDENTIAL UNDERGROUND SERVICE 400 AMPERE (CLASS 320), 120/240 VOLT, 1 PHASE, 3 WIRE			

**SECTION
300
DRAWING
302A**

4. The meter socket may be located above, to the left, or right of the terminating pull section.
5. Pull section cover panels shall be removable, sealable, provided with two lifting handles, and limited to a maximum size of 9 square feet in area.
6. The access opening dimension shown is measured between the return flanges.
7. Cable terminating facilities shall consist of single-position studs with clearance and access requirements complying with Drawing 347.

Exception: The neutral clearance to the back wall of the enclosure may be reduced.

RE	CHANGE	BY	DSGN	APPV	DATE	REV	CHANGE	BY	DSGN	APPV	DATE
A						D					
B						E					
C						F					

SHEET 2 OF 2	Indicates Latest Revision	<input checked="" type="checkbox"/> Completely Revised	<input type="checkbox"/> New Page	<input type="checkbox"/> Information Removed	SECTION 300 DRAWING 302A
	EUSERC MANUAL				
	METER PANEL WITHOUT SOCKET BYPASS FACILITY RESIDENTIAL UNDERGROUND SERVICE 400 AMPERE (CLASS 320), 120/240 VOLT, 1 PHASE, 3 WIRE				

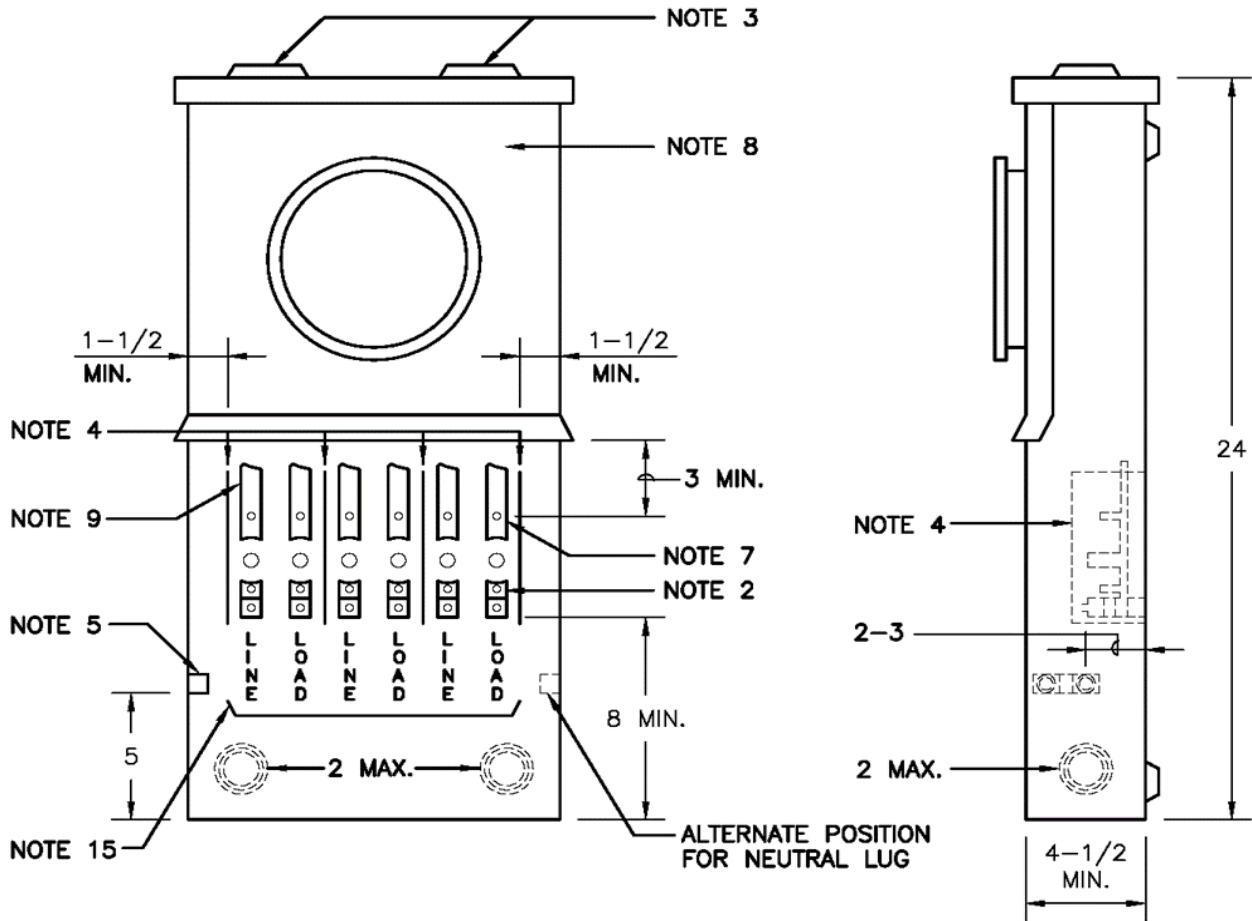

ALL DIMENSIONS SHOWN ARE IN INCHES

RE	CHANGE	BY	DSGN	APPV	DATE	REV	CHANGE	BY	DSGN	APPV	DATE
A						D					
B						E					
C						F					

Indicates Latest Revision Completely Revised New Page Information Removed

SHEET
1 OF 2

EUSERC MANUAL

SAFETY SOCKET BOX WITH FACTORY INSTALLED TEST-BYPASS FACILITIES, 100 AMPERE, 0-600 VOLTS

SECTION
300
DRAWING
304

NOTES:

1. This device may be used for commercial, multi-family residential (not separately metered) and other types of occupancies.
2. Cable terminating facilities shall be aluminum bodied mechanical lugs with a range of No. 6 AWG through No. 1/0 AWG.
3. Hubs capped off if used for underground feed.
4. Rigid insulating barriers.
5. Insulated bondable vertical lay-in, double neutral lug with No. 1/0 wire capacity, mounted on either sidewall.
6. Test-bypass blocks shall be bussed or wired to socket jaws or terminals.
7. Upper test connector studs.
8. All panels shall be independently removable. Meter panel shall be provided with a sealing ring and the meter socket shall be rigidly mounted on support and attached to the meter panel. Test-bypass compartment cover panel shall be sealable and permanently labeled: "DO NOT BREAK SEALS. NO FUSES INSIDE".
9. Test-bypass block detail on Dwg. 312.
10. For 3-phase, 4 wire, connect 7th jaw to body of neutral lug with No. 12 Min. copper wire, white in color.
11. For 3-phase, 4 wire delta, identify right hand test-bypass block (2 poles) as power leg. Identification to be orange in color.
12. For 3-phase, 3 wire, install bus to connect line and load poles together at top of center test-bypass block and connect 5th jaw to this bus, using No. 12 Min. copper wire. Color shall be other than white, gray, green or orange.
13. For 1-phase, 3 wire, provide two test-bypass blocks mounted in the outer positions and a four jaw socket.
14. For 1-phase, 3 wire, 120/208 volt, provide two test-bypass blocks mounted in the outer positions and a five jaw socket. Connect 5th jaw of meter socket to body of neutral lug with a No. 12 Min. copper wire, white in color.
15. Test-bypass block connection sequences shall be LINE-LOAD from left to right and shall be clearly identified in 3/4 inch minimum block letters.
16. Minimum width of access opening shall be 11-1/2 inches.

RE	CHANGE	BY	DSGN	APPV	DATE	REV	CHANGE	BY	DSGN	APPV	DATE
A						D					
B						E					
C						F					

	Indicates Latest Revision	<input checked="" type="checkbox"/>	Completely Revised	<input type="checkbox"/>	New Page	<input type="checkbox"/>	Information Removed
SHEET 2 OF 2	EUSERC MANUAL						SECTION 300 DRAWING 304
SAFETY SOCKET BOX WITH FACTORY INSTALLED TEST-BYPASS FACILITIES, 100 AMPERE, 0-600 VOLTS							

**APS ADDENDUM TO EUSERC REQUIREMENTS
PAGE 304/APS**

NOTES:

1. Eliminate note #12 - APS does not allow 3 Phase 3 Wire services.



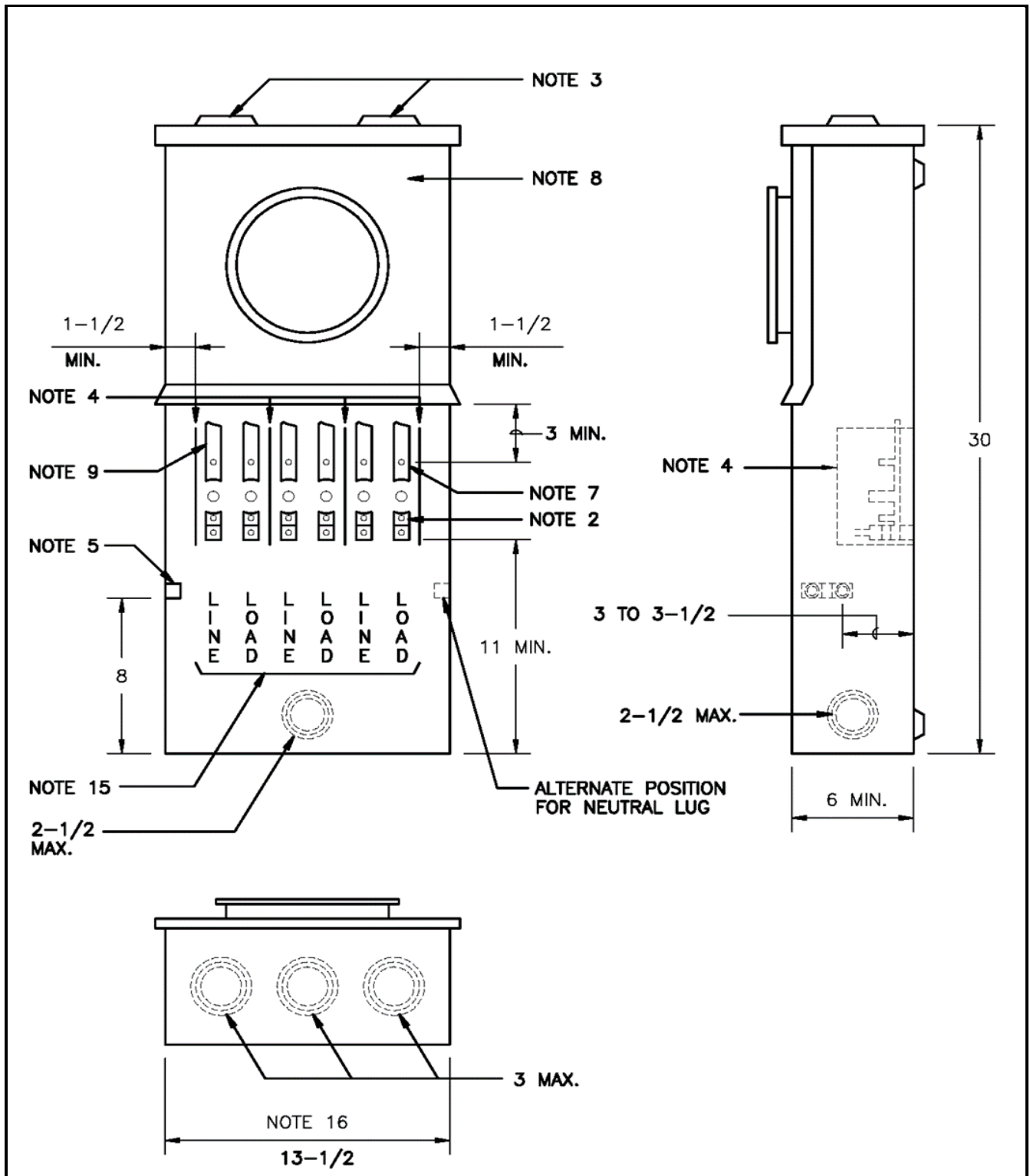

ALL DIMENSIONS SHOWN ARE IN INCHES

RE	CHANGE	BY	DSGN	APPV	DATE	REV	CHANGE	BY	DSGN	APPV	DATE
A						D					
B						E					
C						F					

<input type="checkbox"/> Indicates Latest Revision	<input checked="" type="checkbox"/> Completely Revised	<input type="checkbox"/> New Page	<input type="checkbox"/> Information Removed
--	--	-----------------------------------	--

SHEET
1 OF 2

EUSERC MANUAL
SAFETY SOCKET BOX WITH FACTORY INSTALLED TEST-BYPASS FACILITIES, 200 AMPERE, 0-800 VOLTS

SECTION
300
DRAWING
305

NOTES:

1. This device may be used for commercial, multi-family residential (not separately metered) and other types of occupancies.
2. Cable terminating facilitates shall be aluminum bodied mechanical lugs with a range of No. 1/0 AWG through No. 250 KCMIL.
3. Hubs capped off if used for underground feed and permanently labeled: "DO NOT BREAK SEALS. NO FUSES INSIDE".
4. Rigid insulating barriers.
5. Insulated bondable vertical lay-in, double neutral lug with No. 250 KCMIL wire capacity, mounted on either sidewall.
6. Test-bypass blocks shall be bussed or wired to socket jaws or terminals.
7. Upper test connector studs.
8. All panels shall be independently removable. Meter panel shall be provided with a sealing ring and the meter socket shall be rigidity mounted on support and attached to the meter panel. Test-bypass compartment cover panel shall be sealable and permanently labeled: "DO NOT BREAK SEALS. NO FUSES INSIDE".
9. Test-bypass block detail on Dwg. 312.
10. For 3-phase, 4 wire, connect 7th jaw to body of neutral lug with No. 12 Min. copper wire, white in color.
11. For 3-phase, 4 wire delta, identify right hand test-bypass block (2 poles) as power leg. Identification to be orange in color.
12. For 3-phase, 3 wire, install bus to connect line and load poles together at top of center test-bypass block and connect 5th jaw to this bus, using No. 12 Min. copper wire. Color shall be other than white, gray, green or orange.
13. For 1-phase, 3 wire, provide two test-bypass blocks mounted in the outer positions and a four jaw socket.
14. For 1-phase, 3 wire, 120/208 volt, provide two test-bypass blocks mounted in the outer positions and a five jaw socket. Connect 5th jaw of meter socket to body of neutral lug with a No. 12 Min. copper wire, white in color.
15. Test-bypass block connection sequences shall be LINE-LOAD from left to right and shall be clearly identified in 3/4 inch minimum block letters.
16. Minimum width of access opening shall be 11-1/2 inches.

RE	CHANGE	BY	DSGN	APPV	DATE	REV	CHANGE	BY	DSGN	APPV	DATE
A						D					
B						E					
C						F					

SHEET 2 OF 2	Indicates Latest Revision	<input checked="" type="checkbox"/> Completely Revised	<input type="checkbox"/> New Page	<input type="checkbox"/> Information Removed	SECTION 300 DRAWING 305
	EUSERC MANUAL				
	SAFETY SOCKET BOX WITH FACTORY INSTALLED TEST- BYPASS FACILITIES, 200 AMPERE, 0-800 VOLTS				

**APS ADDENDUM TO EUSERC REQUIREMENTS
PAGE 305/APS**

NOTES:

1. Eliminate note #12 - APS does not allow 3 Phase 3 Wire services.
2. The Title in the Title Block for this Drawing should read:
SAFETY SOCKET BOX WITH FACTORY INSTALLED TEST-BYPASS FACILITIES, 200 AMPERE,
0-600 VOLTS (not 800 VOLTS).



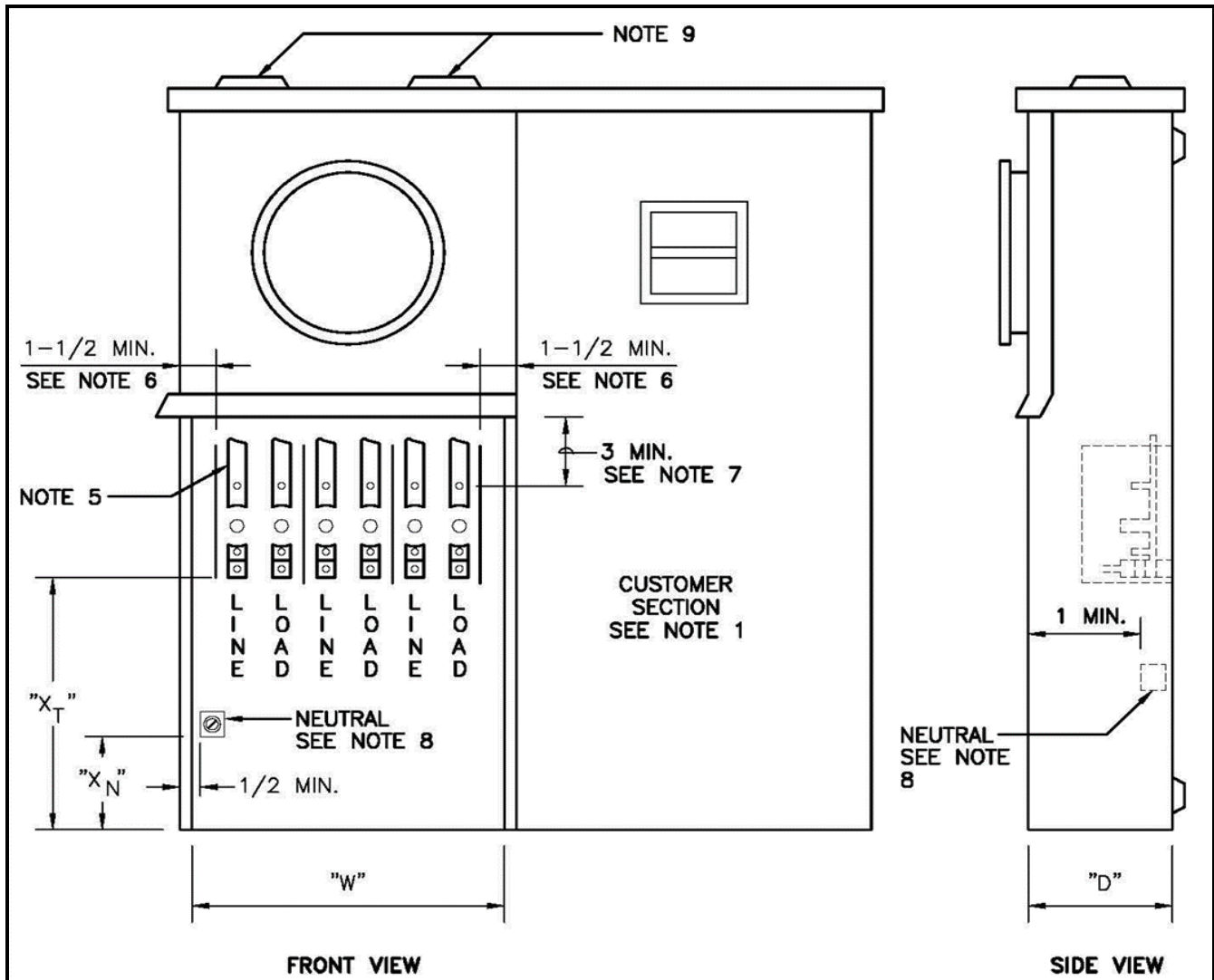

TABLE - MINIMUM DIMENSIONS

PANEL TYPE	PANEL RATING* (AMPERS)	"D"	"W" SEE NOTE 4	"XT"	"XN"
STANDARD	100	4-1/2	11-1/2	8	5
HEAVY-DUTY	200	6	13-1/2	11	8

* Continuous-duty

NOTES:

- The panel shown above is typical with the customer's distribution section located to the side of the metering compartment. The distribution section may also be located below the test-bypass compartment (overhead supply only) or above the meter panel.

ALL DIMENSIONS SHOWN ARE IN INCHES

RE	CHANGE	BY	DSGN	APPV	DATE	REV	CHANGE	BY	DSGN	APPV	DATE
A						D					
B						E					
C						F					

Indicates Latest Revision
 Completely Revised
 New Page
 Information Removed

SHEET
1 OF 2

EUSERC MANUAL
**COMBINATION SAFETY-SOCKET PANEL WITH FACTORY
 INSTALLED TEST BLOCKS AND SERVICE DISCONNECT,
 100 AND 200 AMPERES, 0-600 VOLTS**

**SECTION
 300
 DRAWING
 305A**

2. Meter socket shall be mounted on a rigid support and attached to the meter socket panel.
3. All panels shall be independently removable. Meter panel shall be provided with a sealing ring and the meter socket shall be rigidly mounted on a support and attached to the meter panel. test-bypass compartment cover shall be sealable.
4. Minimum test compartment access opening dimension.
5. Test-bypass blocks with rigid insulating barriers shall be furnished installed, and bussed or wired to the meter socket by the manufacturer as follows:
 - a. For 1 ϕ , 3-wire, provide two test-bypass blocks mounted in the outer positions and a 4-jaw socket. For 120/208 volts, 1 ϕ 3-wire, provide two test-bypass blocks mounted in the outer positions and a 5-jaw socket connect the 5th jaw of the meter socket to the neutral lug with a white No. 12 AWG (minimum) copper wire.
 - b. For 3 ϕ , 3-wire, provide three test-bypass blocks and a 5-jaw meter socket-connect the line and load poles together at the top of the center position test-bypass block with a bus section and connect the bus to the 5th jaw of the meter socket with a No. 12 AWG (minimum) copper wire. Color used to identify the wire shall not be either white, gray, green or orange.
 - c. For 3 ϕ , 4-wire, provide three test-bypass blocks and a 7-jaw meter socket-connect the 7th jaw of the meter socket to the neutral lug with a white No. 12 AWG (minimum) copper wire. For 120/240 volts, 4-wire delta, the right hand test-bypass block shall be the power leg (measures 208 volts-to-ground) and shall be identified with an orange color.
 - d. Test-bypass block connection sequence shall be LINE-LOAD from left to right and shall be clearly identified in 3/4-inch minimum block letters.
 - e. Cable terminals shall be aluminum-bodied mechanical lugs with a range on No. 6 AWG through 1/0 AWG for the 100 ampere test-bypass block and No. 1/0 AWG through 250 KCMIL for the 200 ampere test-bypass block.
6. 1-1/2 inch (minimum) dimension measured from compartment side to the test-bypass block rigid insulating barrier.
7. 3-inch (minimum) dimension measured from the upper test connector stud (stud "A") to the socket meter cover.
8. The neutral terminal may be provided as follows:
 - a. A single mechanical lug or lay-in lug, located on either side or side wall. The lug shall be mounted on a neutral bus bar extending into, and terminating in, the customer section.
 - b. Two mechanical lugs or lay-in lugs, located on either side or side wall. the neutral conductor provided from one of the lugs to the neutral bus in the customer section may be factory or field installed.
 - c. Overhead supply only - a single insulated, bondable, vertical, lay-in lug located on either side or side wall with the neutral conductor installed unbroken through the lug and terminating on the neutral bus in the customer section.
9. Knockouts for the service supply conduit may be cut in the locations shown at the top of the panel.

RE	CHANGE	BY	DSGN	APPV	DATE	REV	CHANGE	BY	DSGN	APPV	DATE
A						D					
B						E					
C						F					

SHEET 2 OF 2	<input type="checkbox"/> Indicates Latest Revision	<input checked="" type="checkbox"/> Completely Revised	<input type="checkbox"/> New Page	<input type="checkbox"/> Information Removed	SECTION 300 DRAWING 305A
	EUSERC MANUAL				
	COMBINATION SAFETY-SOCKET PANEL WITH FACTORY INSTALLED TEST BLOCKS AND SERVICE DISCONNECT, 100 AND 200 AMPERES, 0-600 VOLTS				

**APS ADDENDUM TO EUSERC REQUIREMENTS
PAGE 305A/APS**

NOTES:

1. Eliminate note #5b - APS does not allow 3 Phase 3 Wire services.



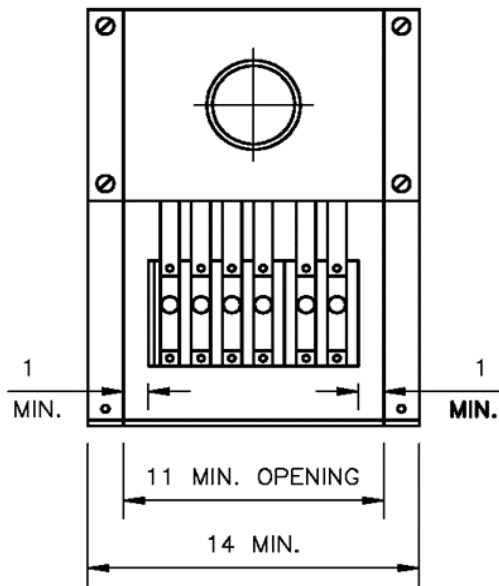

**BARRIER
(SEE NOTE 6)**

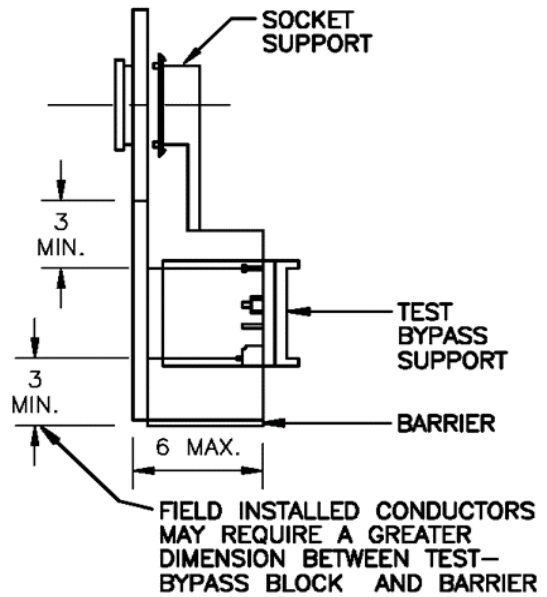

**BARRIER
(SEE NOTE 6)**

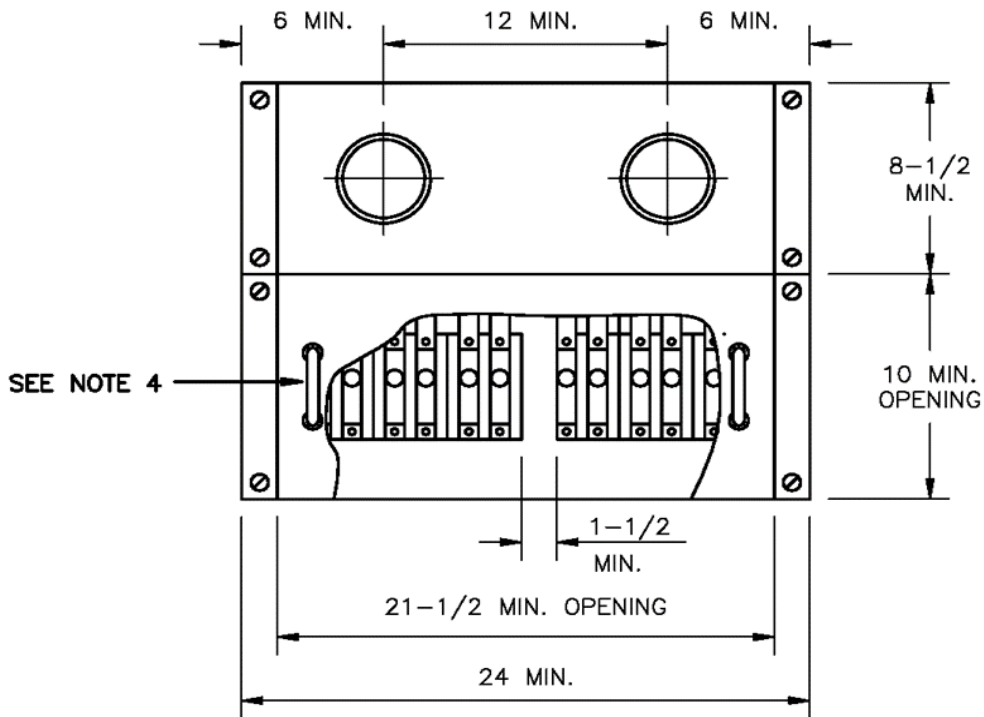

**TEST-BYPASS BLOCK WITH
4 RIGID INSULATING BARRIERS
(SEE NOTE 1)**

ALL DIMENSIONS SHOWN ARE IN INCHES

RE	CHANGE	BY	DSGN	APPV	DATE	REV	CHANGE	BY	DSGN	APPV	DATE
A						D					
B						E					
C						F					

Indicates Latest Revision Completely Revised New Page Information Removed

EUSERC MANUAL

SHEET
1 OF 2

**SELF-CONTAINED METERS INSTALLED IN
SWITCHBOARDS 0-200 AMPS, 0-600 VOLTS**

**SECTION
300
DRAWING
306**

NOTES:

1. Test-bypass blocks with rigid insulating barriers shall be furnished, installed, and wired or bussed to the meter socket by the manufacturer. Connection sequence shall be LINE-LOAD from left to right and shall be identified IN 3/4 inch block letters.
2. Metered conductors shall not pass through adjacent metering compartments except in enclosed wireways. To insure proper identification of cables in factory cabled equipment, metered cables (except in the test-bypass area), shall be either physically barriered or bundled so as to separate them from un-metered cable or permanently marked and isolated from un-metered cables. Physical barriers will not be required if the un-metered conductors are bus.
3. Meter panels shall be removable with a maximum of two meters per panel. Meter panels shall be provided with a sealing ring for each meter socket and each meter socket shall be rigidly mounted on a support and attached to the meter panel.
4. Test-bypass block cover panel shall be sealable and fitted with a lifting handle. All panels exceeding 16 inches in width shall require two lifting handles.
5. When a neutral is required for metering or testing, an insulated neutral terminal shall be provided behind each test-bypass cover panel. The terminal shall be readily accessible when the cover panel is removed and shall be individually connected to the neutral bus with a minimum size No. 12 AWG copper wire.
6. A factory-installed, full-width insulating barrier shall be located at the bottom of each test-bypass compartment. In addition, a full width and depth isolating barrier shall be located below the bottom test-bypass compartments and above the load terminals of the meter disconnect devices. If a factory-installed rear load wireway is provided, the isolating barrier shall extend back to that wireway. Ventilation openings, when provided, shall not exceed a maximum diameter of 3/8 inch. A slot in the isolating barrier provided for the load conductors supplied from the test-bypass blocks shall be a maximum of 3 inches in depth and may extend to the width of the meter disconnect devices. The slot may not be located in the front 6 inches of the test-bypass compartment insulating barrier.
7. For 3 phase, 4 wire, connect 7th jaw of meter socket to body of neutral lug with a white No. 12 AWG copper wire.
8. For 3 phase, 4 wire delta, identify right hand test-bypass block (2 poles) as power leg. identification to be orange in color.
9. For 3 phase 3 wire, install bus to connect line and load poles together at top of center test-bypass block and connect 5th jaw of meter socket to this bus using minimum No. 12 AWG copper wire. Color used to identify the wire shall not be white, gray, green, or orange.
10. For 1 phase, 3 wire, omit center test-bypass block.
11. For 1 phase, 3 wire, 208Y/120 volts, omit center test-bypass block and connect 5th jaw of meter socket to body of neutral lug with white No. 12 AWG copper wire.
12. Separate line and load conductors shall be installed by the contractor or manufacturer for each meter socket.
13. All access panels shall be sealable. See drawing 300, note II (I).
14. All panels shall be independently removable. Meter panel shall be provided with a sealing ring and the meter socket shall be rigidly mounted on support and attached to the meter panel. Test-bypass compartment cover panel shall be sealable and permanently labeled: "DO NOT BREAK SEALS. NO FUSES INSIDE".

RE	CHANGE	BY	DSGN	APPV	DATE	REV	CHANGE	BY	DSGN	APPV	DATE
A						D					
B						E					
C						F					

	<input type="checkbox"/> Indicates Latest Revision	<input checked="" type="checkbox"/> Completely Revised	<input type="checkbox"/> New Page	<input type="checkbox"/> Information Removed	
SHEET 2 OF 2	EUSERC MANUAL SELF-CONTAINED METERS INSTALLED IN SWITCHBOARDS 0-200 AMPS, 0-600 VOLTS				SECTION 300 DRAWING 306

**APS ADDENDUM TO EUSERC REQUIREMENTS
PAGE 306/APS**

NOTES:

1. Eliminate note #9 - APS does not allow 3 Phase 3 Wire services.
2. Minimum width of NEMA 3R Cabinet shall be 30". Dimensioned widths of 14 & 24 inches shown on EUSERC dwg. no. 306, sht. 1 of 2 are not acceptable.



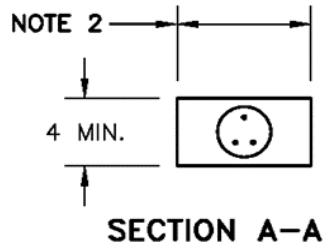
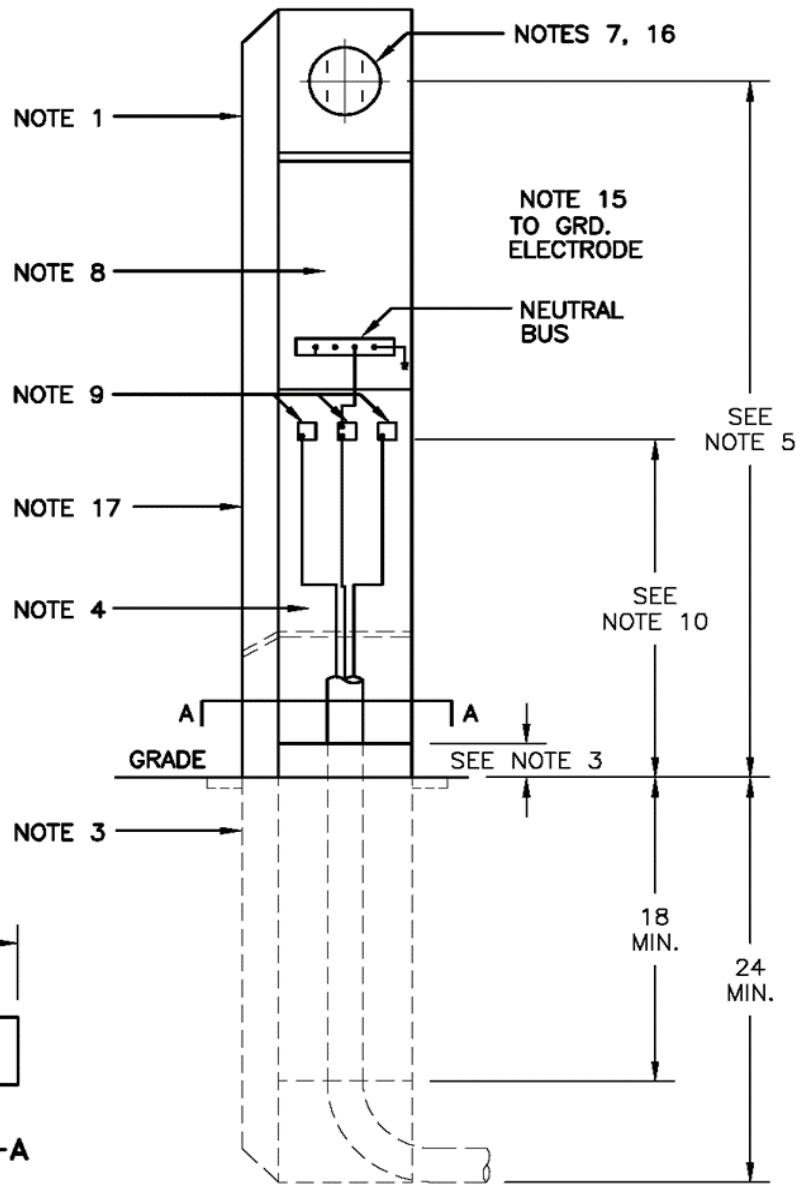

NOTES:

GENERAL CONSTRUCTION:

1. This type post shall have minimum rating of 100 amperes. Construction, material, and corrosive-resistant finish shall be approved by a Committee-recognized test laboratory.
2. Minimum width of access opening shall be 7-1/2 inches.
3. The minimum depth of the post in the ground shall be 24 inches, with openings at the base to permit the service lateral conduit or conductors to sweep into the post from the front (meter side). A fixed panel shall extend 2 inches minimum to 6 inches maximum above grade, and 18 inches minimum below grade.

ALL DIMENSIONS SHOWN ARE IN INCHES

RE	CHANGE	BY	DSGN	APPV	DATE	REV	CHANGE	BY	DSGN	APPV	DATE
A						D					
B						E					
C						F					

Indicates Latest Revision
 Completely Revised
 New Page
 Information Removed

SHEET
1 OF 2

EUSERC MANUAL
**UNDERGROUND SERVICE AND METER POST FOR
 MOBILE HOME OR NON-COMMERCIAL USE 200
 AMPERES MAXIMUM, 240 VOLTS MAXIMUM**

**SECTION
 300
 DRAWING
 307**

4. Adequate ventilation shall be provided to inhibit the condensation of moisture within the enclosure.
5. The minimum meter height shall be 36 inches above the grade line when the meter is enclosed or 48 inches when exposed. Consult the serving agency for permissible deviations.
6. The service cable pull and terminating section shall be accessible from either the front or rear of the post by removing an 8 inch minimum width sealable panel (or panels). The removable panel (or panels) shall extend from the top of the fixed panel (See note 3) and when removed, allow full access to the terminating lugs. The service cable pull and terminating section space shall be restricted to serving agency use.
7. If the meter is enclosed, the enclosing cover shall be hinged and self-supporting, equipped with a reading window and be removable for meter testing or inspection.
8. The service main disconnect and power outlet section shall have barriers installed to prevent access to the service cable pull and termination section and to un-metered conductors which connect to the socket.

TERMINATING FACILITIES, WIRING AND CONNECTIONS:

9. Termination for service conductors shall be aluminum-bodied mechanical lugs accepting two sets of conductors with a range of No. 2 AWG through 350 KCMIL (consult the utility for permissible deviations).
10. Lug height, measured from the bottom of the terminating lug from the top of the fixed panel, shall be a 18 inches minimum to 48 inches maximum.
11. The space between the lugs, from lugs to sides of post, from lugs to any grounded surface, or from lugs to panel above, shall be 1-1/2 inches minimum. Rigid insulating barriers, projecting 1/4 inch minimum beyond any energized parts, are required when the required lug spacing is reduced.
12. Terminating lugs may be positioned either in line or staggered and access shall be unobstructed when all service conductors are in place.
13. The conductors which extend to the meter socket shall be connected at the service terminating lugs independently of the connection for the service laterals.
14. The pedestal shall be factory-wired from the service terminating lugs to the meter socket. The conductors shall be located in a separate or barriered raceway.

GROUNDING FACILITIES:

15. An accessible equipment grounding lug shall be provided.

METERING FACILITIES:

16. Meter panel shall be provided with a sealing ring and the meter socket shall be rigidly mounted on a support and attached to the meter panel.

ENCLOSURE ATTACHMENTS:

17. For authorization to attach telephone and cable TV terminating facilities to the post, consult the serving agency.

RE	CHANGE	BY	DSGN	APPV	DATE	REV	CHANGE	BY	DSGN	APPV	DATE
A						D					
B						E					
C						F					

SHEET 2 OF 2	Indicates Latest Revision	<input checked="" type="checkbox"/>	Completely Revised	New Page	Information Removed
	EUSERC MANUAL				
	UNDERGROUND SERVICE AND METER POST FOR MOBILE HOME OR NON-COMMERCIAL USE 200 AMPERES MAXIMUM, 240 VOLTS MAXIMUM				
SECTION 300 DRAWING 307					

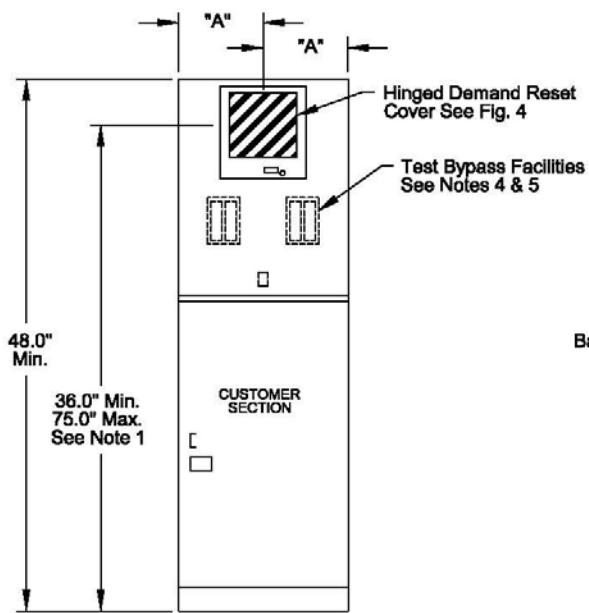

Fig. 1
FRONT VIEW

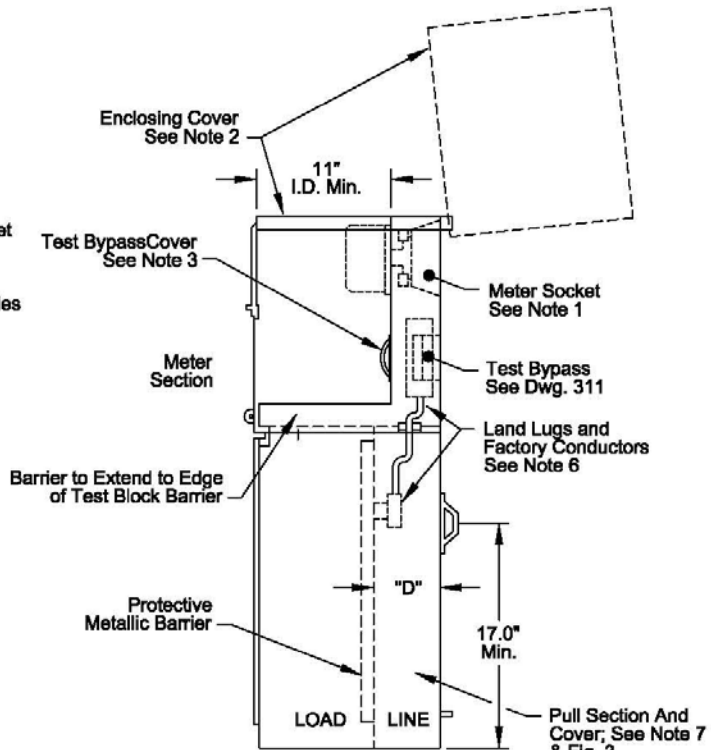

Fig. 2
SIDE VIEW

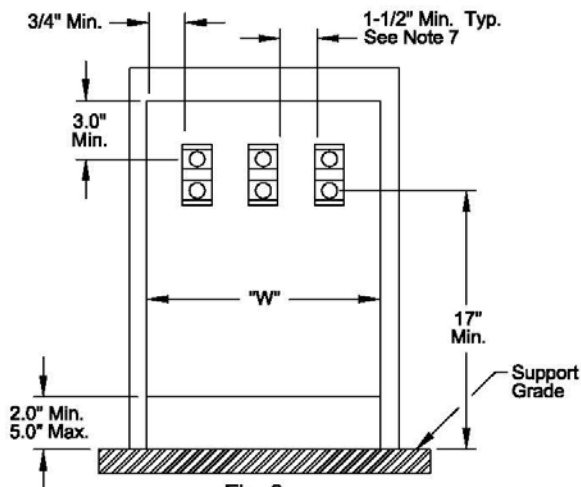

Fig. 3
WIREWAY PULL SECTION

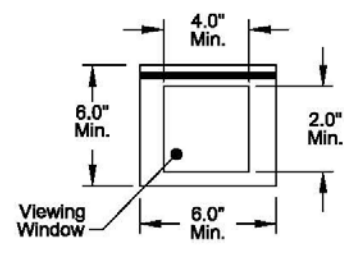

Fig. 4
FRONT VIEW
Hinged Demand Reset
with Polycarbonate View

Table 1 - Minimum Dimensions		
Service	A**	W*
1 Phase	10"	10-1/2
3 Phase		12-1/2

** See Note 2
* See Note 6

All Dimensions Shown Are In Inches

RE	CHANGE	BY	DSGN	APPV	DATE	REV	CHANGE	BY	DSGN	APPV	DATE
A	Updated Views				10/18	D					
B						E					
C						F					

SHEET 1 OF 2	Indicates Latest Revision	<input checked="" type="checkbox"/> Completely Revised	<input type="checkbox"/> New Page	<input type="checkbox"/> Information Removed
	EUSERC MANUAL			
	COMMERCIAL HINGED TOP SERVICE PEDESTALS 0-200 AMPERES, 0-600 VOLTS			
SECTION 300 DRAWING 308				

Notes:

1. The meter panel shall be provided with a sealing ring and the meter socket shall be rigidly mounted on a support and attached to the meter panel. Ringless sockets are not acceptable. Meter height is measured from the center of the meter socket.
2. The meter socket shall be enclosed and the enclosing cover shall be:
 - a. Hinged to allow the top front and sides to be rotated back or laterally as one unit to expose the metering section. The lifting force required to open the cover shall not exceed 25 pounds.
 - b. Equipped with a lifting handle.
 - c. Sealable and lockable with a padlock having a 5/16 inch lack shaft.
 - d. Provided with a demand reset cover with a viewing window (See Fig. 3). The reset cover shall be sealable and lockable with a padlock having 5/16 inch lock shaft.
3. Test-bypass compartment covers shall be sealable and provided with a lifting handle. Covers exceeding 16 inches in width shall require two lifting handles.
4. Test-bypass blocks with rigid barriers shall be furnished, installed and wired or bussed to the meter socket by the manufacturer. Connection sequences shall be LINE-LOAD from left to right and clearly identified by 3/4 inch minimum black letter labeling. See Drawings 311 and 312 for test-bypass block details.
5. Test-bypass section shall be installed with the following clearances:
 - a. 3-inches of vertical clearance from the upper test connector stud to the upper compartment access opening and 3-inches from the center of the cable terminal screw to the lower compartment access opening.
 - b. 1-1/2 inches of side clearance from the rigid insulating barriers to the compartment sides and 1 inch t to the compartment access opening.
6. When a neutral is required for metering or testing, an insulated neutral terminal shall be provided behind the test-bypass compartment cover. The terminal shall be readily available when the cover is removed and shall be connected to the neutral terminal in the pull section by a minimum size no. 12 copper wire.
7. The terminating pull section shall:
 - a. Comply with minimum dimensions shown in Table an Sheet 1, be equipped with lifting handles, and accept a minimum 3-inch conduit. The "W" dimension is measured between the access opening return flanges.
 - b. Be equipped with aluminum-bodied, pressure-type lugs with range of No. 6 AWG through 250 KCMIL, for termination of the service supply conductors. Insulated cable or bus shall be provided between the terminating lugs and the test-bypass facilities.
 - c. A 1-1/2" minimum spacing shall be provided between the energized lugs or bussing. The 1-1/2" spacing may be reduced if rigid insulating barriers (1/16" minimum thickness) are provided which extend a minimum of 1/2" beyond any exposed energized part when the maximum wire size is installed.
 - d. Have a protective metal barrier (16 gauge minimum) installed between the pull section and the customer section. The barrier shall provide 1/4-inch minimum clearance between the customer section wall and barrier to prevent damage by screws and bolts from protruding into the pull section area.
8. The utility pull section cover shall be equipped with a lifting handle and be sealable and lockable with a padlock having a 5/16 inch lock shaft.
9. Internal equipment attached to the outer walls of the enclosure shall be secured in place with devices that may not be loosened from the outside. Screws or bolts requiring special tools for installation or removal are not acceptable.
10. For structural mounting and support of the pedestal consult the serving agency.

RE	CHANGE	BY	DSGN	APPV	DATE	REV	CHANGE	BY	DSGN	APPV	DATE
A	Updated Notes				10/18	D					
B						E					
C						F					

SHEET 2 OF 2	Indicates Latest Revision	<input checked="" type="checkbox"/> Completely Revised	<input type="checkbox"/> New Page	<input type="checkbox"/> Information Removed	SECTION 300 DRAWING 308
	EUSERC MANUAL				
	COMMERCIAL HINGED TOP SERVICE PEDESTALS 0-200 AMPERES, 0-600 VOLTS				

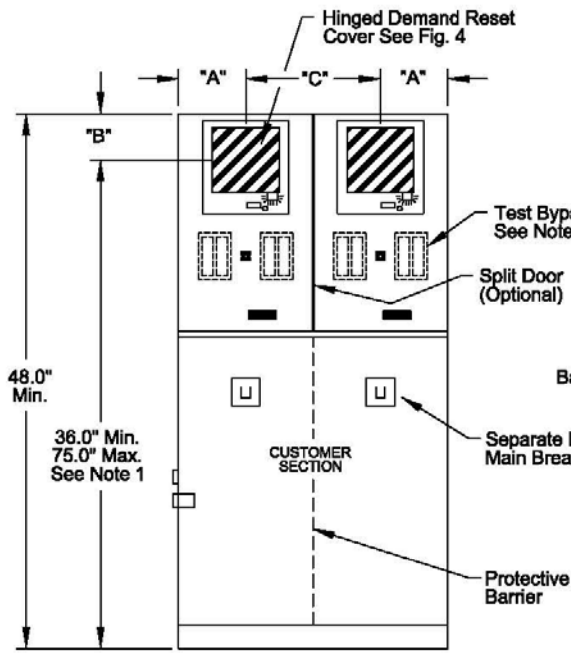

Fig. 1
FRONT VIEW

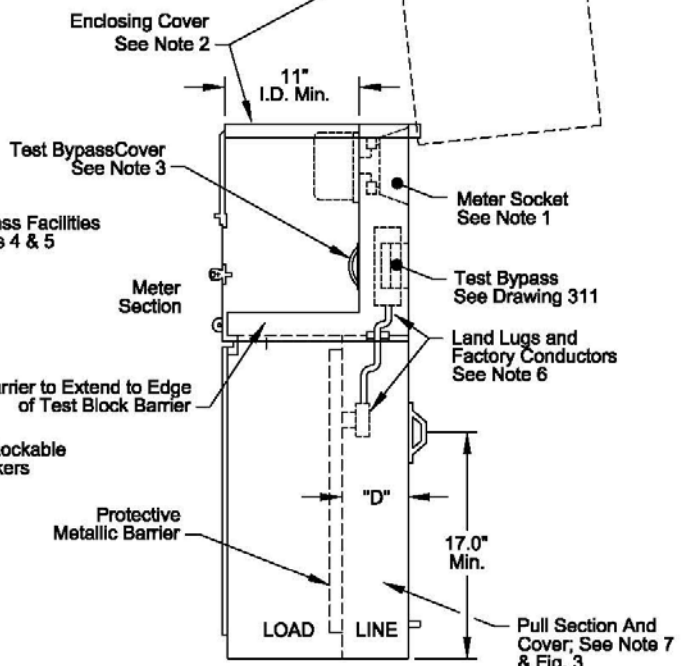

Fig. 2
SIDE VIEW

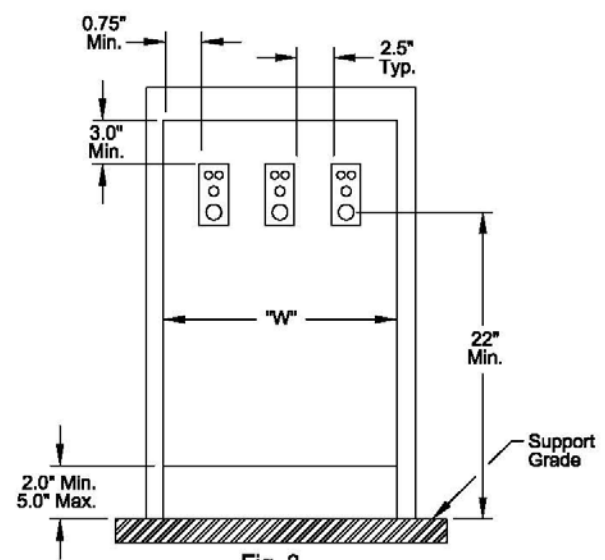

Fig. 3
WIREWAY PULL SECTION

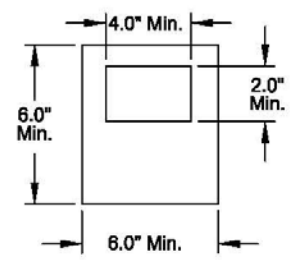

Fig. 4
FRONT VIEW
Hinged Demand Reset
with Polycarbonate View

Service	"A"	"B"	"C"	"D"	"W"
1 Phase	6.0"	4.5"	12.0"	5.25"	12.0"

All Dimensions Shown Are In Inches

RE	CHANGE	BY	DSGN	APPV	DATE	REV	CHANGE	BY	DSGN	APPV	DATE
A	Added as new EUSERC Drawing				05/18	D					
B						E					
C						F					

SHEET 1 OF 2	Indicates Latest Revision	<input checked="" type="checkbox"/> Completely Revised	<input type="checkbox"/> New Page	<input type="checkbox"/> Information Removed
	EUSERC MANUAL			
	DUAL SOCKET COMMERCIAL HINGED TOP SERVICE PEDESTAL 0-400 AMPERES, 0-600 VOLTS SINGLE PHASE			
SECTION 300 DRAWING 308A				

Notes:

1. The meter panel shall be provided with a sealing ring and the meter socket shall be rigidly mounted on a support and attached to the meter panel. Ringless sockets are not acceptable. Meter height is measured from the center of the meter socket. Meter socket shall be no larger than 200A. Max. per section.
2. The meter socket shall be enclosed and the enclosing cover shall be:
 - a. Hinges to allow the top front and sides to be rotated back or laterally as one unit metering compartment. The "A" dimension applies then the metering compartment side panels are fixed in place and obstruct the meter socket side clearance. The lifting force required to open the cover shall not exceed 25 pounds.
 - b. Equipped with a lifting handle.
 - c. Sealable and lockable with a padlock having a 5/16" inch lock shaft.
 - d. Provide with a demand reset cover with a viewing window (See Fig. 3). The reset cover shall be sealable and lockable with a padlock having 5/16 inch lock-shaft.
3. Test-bypass compartment cover shall be sealable and provided with a lifting handles, covers exceeding 16 inches in width shall require two lifting handles.
4. Test-bypass blocks with rigid barriers shall be furnished, installed and wired or bussed to the master socket by the manufacturer. Connection sequence shall be LINE-LOAD from left to right and clearly identified by 3/4 inch minimum block letter labeling. See Drawing 311 and 312 for test-bypass block details.
5. The terminating pull section shall:
 - a. 3 inches of vertical clearance for the upper test connector stud to the upper compartment access opening and 3 inches from the center of the center of the cable terminal screw to the lower compartment access opening.
 - b. 1-1/2 inches of side clearance from the rigid insulating barriers to the compartment sides and 1 inch to the compartment access opening.
6. When a neutral is required for metering or testing, an insulated neutral terminal shall be provided behind the test-bypass compartment cover. The terminal shall be readily available when the cover is removed and shall be connected to the neutral terminal in the pull section by a minimum size no. 12 copper wire.
7. The terminating pull section shall:
 - a. Comply with minimum dimensions shown in Table on Sheet 1, be equipped with lifting handles, and accept a minimum 3-inch conduit. The "W" dimension is measured between the access opening return flanges.
 - b. Be equipped with aluminum-bodied, pressure-type lugs with range of No. 6 AWG through 350 KCMIL, for termination of the service supply conductors. Insulated cable or bus shall be provided between the terminating lugs and the test-bypass facilities.
 - c. 1-1/2" minimum spacing shall be provided between the energized lugs or bussing. The 1-1/2" spacing may be reduced if rigid insulating barrier (1/16" minimum thickness) are provided which extend a minimum of 1/2" beyond any exposed energized part when the maximum wire size installed.
 - d. Have a protective metal barrier (16 gauge minimum) installed between the pull section and the customer section. The barrier shall provide 1/4 inch minimum clearance between the customer section wall and barrier to prevent damage by screws and bolts from protruding into the pull section area.
8. The utility pull section cover shall be equipped lifting handle and be sealable and lockable with a padlock having a 5/16 inch lockshaft.
9. Internal equipment attached to the outer walls of the enclosure shall be secured in place with devices that may not be loosened from outside. Screw or bolts requiring special tools for installation or removal are not acceptable.
10. For structural mounting and support of the pedestal consult the serving agency.

RE	CHANGE	BY	DSGN	APPV	DATE	REV	CHANGE	BY	DSGN	APPV	DATE
A	Added as new EUSERC Drawing				05/18	D					
B						E					
C						F					

SHEET 2 OF 2	<input type="checkbox"/> Indicates Latest Revision	<input checked="" type="checkbox"/> Completely Revised	<input type="checkbox"/> New Page	<input type="checkbox"/> Information Removed
	EUSERC MANUAL			
	DUAL SOCKET COMMERCIAL HINGED TOP SERVICE PEDESTAL 0-400 AMPERES, 0-600 VOLTS SINGLE PHASE			
SECTION 300 DRAWING 308A				

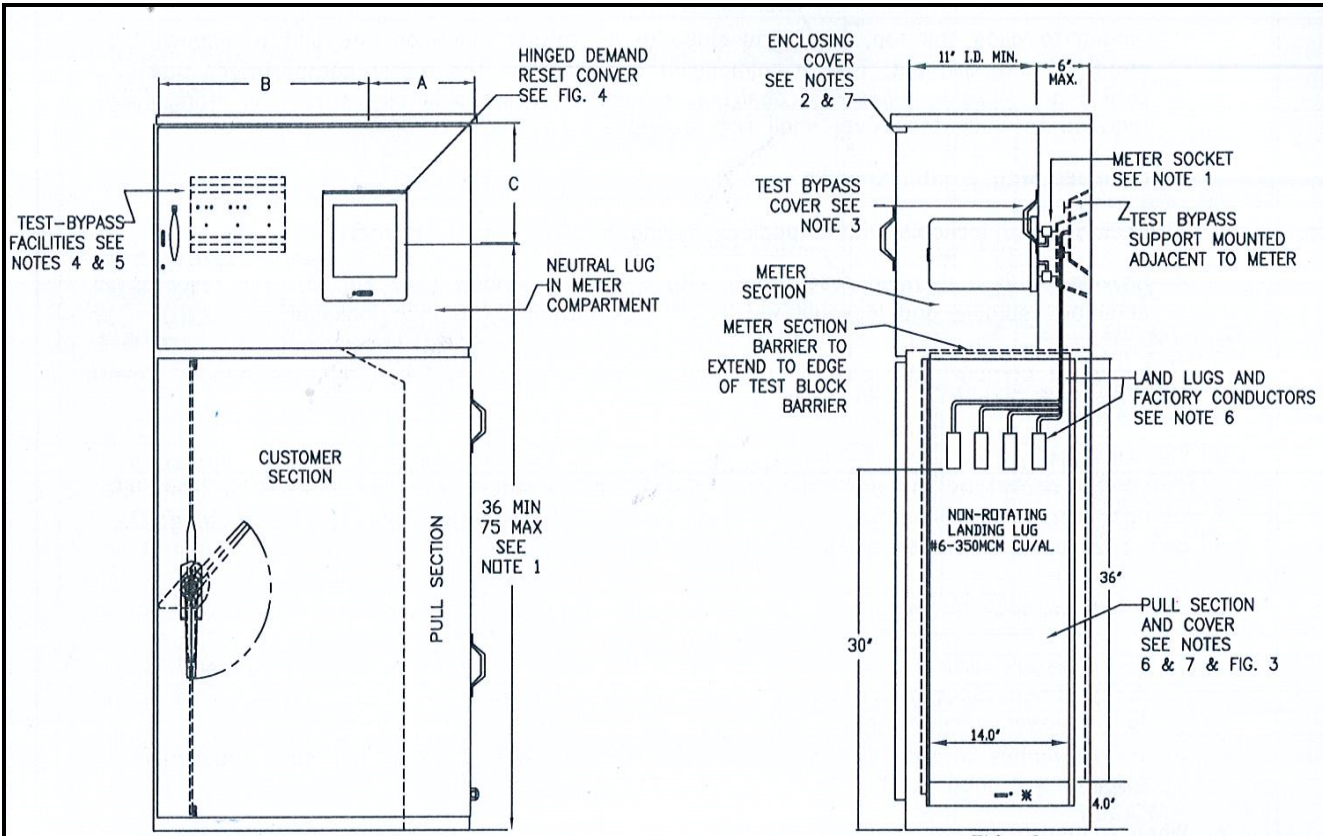

FIG. 1
FRONT VIEW

FIG. 2
SIDE VIEW

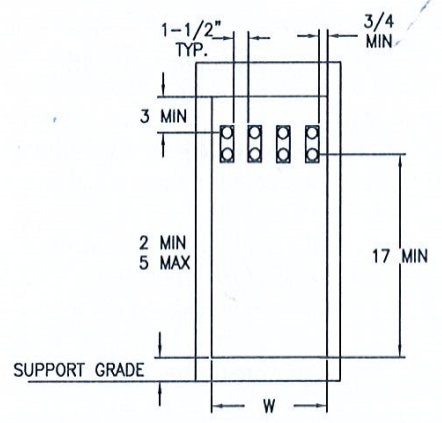

FIG. 3
WIREWAY PULL SECTION

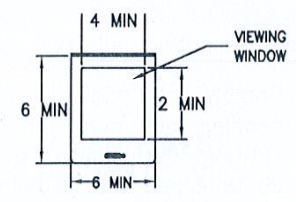

FIG. 4

HINGED DEMAND RESET
WITH POLYCARBONATE VIEWING

TABLE 1 - MINIMUM DIMENSIONS

SERVICE	W*	A**	B**	C**
1 PHASE	10-1/2	10	20	9
3 PHASE	12-1/2			

* SEE NOTE 6 & 7 ** SEE NOTE 2 & 7

ALL DIMENSIONS ARE SHOWN IN INCHES

RE	CHANGE	BY	DSGN	APPV	DATE	REV	CHANGE	BY	DSGN	APPV	DATE
A	UPDATED DRAWING				1/16	D					
B						E					
C						F					

SHEET 1 OF 2	Indicates Latest Revision	<input checked="" type="checkbox"/> Completely Revised	<input type="checkbox"/> New Page	<input type="checkbox"/> Information Removed	SECTION 300 DRAWING 309
	EUSERC MANUAL				
	COMMERCIAL FIXED TOP SERVICE PEDESTALS 0-200 AMPERES, 0-600 VOLTS				

NOTES:

1. The meter panel shall be provided with a sealing ring and the meter socket shall be rigidly mounted on a support and attached to the meter panel. Ringless sockets are not acceptable. Meter height is measured from the center of the meter-socket.
2. The meter shall be enclosed and the enclosing cover shall meet the following conditions:
 - a. Constructed with fixed top and sided with access to the metering compartment provided through a hinged door. Meter socket shall be located on the hinged side of the enclosure. The hinged door shall be equipped with a device to hold the door in the open position at 90 degrees or more.

Note: "A" and "B" dimensions are measured from the center of the meter socket to the access opening return flanges.

 - b. Sealable and lockable with a padlock having a 5/16-inch lock shaft.
 - c. Provided with a demand reset cover with a viewing window (see fig. 4). The reset cover shall be sealable and lockable with a padlock having a 5/16-inch lock shaft.
3. Test-bypass compartment covers shall be sealable and fitted with a lifting handle. Covers exceeding 16 inches in width shall require two lifting handles.
4. Test-bypass blocks with rigid barriers shall be furnished, installed and wired or bussed to the meter socket by the manufacturer. Connection sequences shall be LINE-LOAD from left to right and clearly identified by 3/4 inch minimum block letter labeling. See Drawing 311 and 312 for test-bypass block details.
5. Test-bypass shall be installed with the following clearances:
 - a. 3-inches of vertical clearance from the upper test connector stud to the upper compartment access opening and 3-inches from the center of the cable terminal screw to the lower compartment access opening.
 - b. 1-1/2 inches of side clearance from the rigid insulating barriers to the compartment sides and 1 inch to the compartment access openings.
6. When a neutral is required for metering or testing, an insulated neutral terminal shall be provided behind the test-bypass compartment cover. The terminal shall be readily available when the cover is removed and shall be connected to the neutral terminal in the pull section by a minimum size no. 12 copper wire.
7. The terminating pull section shall:
 - a. Comply with the minimum dimensions shown in Table on sheet 1, be equipped with lifting handles, and accept a minimum 3-inch conduit. The "W" dimension is measured between the access opening return flanges.
 - b. Be equipped with an aluminum-bodied, pressure-type lugs, with a range of No. 6 AWG through 350 Kcmil, for termination of the service supply conductors. Insulated cable or bus shall be provided between the termination lugs and the test-bypass facilities.
 - c. A 1-1/2" minimum spacing shall be provided between the energized lugs or bussing. The 1-1/2" spacing may be reduced if rigid insulating barriers (1/16" minimum thickness) are provided which extend a minimum of 1/2" beyond any exposed energized part when the maximum wire size is installed.
 - d. Have a protective metal barrier (16 gauge minimum) provided between the pull section and the customer distribution section. There shall be a 1/4 inch minimum clearance between the customer section wall and the barrier to prevent screws and bolts from protruding into the pull section.
8. Utility compartment covers (i.e., meter cover, demand reset cover, and pull section) shall be sealable and lockable with a padlock having a 5/16 inch lock shaft.
9. Internal equipment attached to the outer walls of the enclosure shall be secured in place with devices that may not be loosened from the outside. Screws or bolts requiring special tools for installation or removal are not acceptable.
10. For structural mounting and support of the pedestal consult the serving agency.

RE	CHANGE	BY	DSGN	APPV	DATE	REV	CHANGE	BY	DSGN	APPV	DATE
A	UPDATED DRAWING				1/16	D					
B						E					
C						F					

SHEET 2 OF 2	Indicates Latest Revision	<input checked="" type="checkbox"/> Completely Revised	New Page	Information Removed
	EUSERC MANUAL			
	COMMERCIAL FIXED TOP SERVICE PEDESTALS 0-200 AMPERES, 0-600 VOLTS			
SECTION 300 DRAWING 309				

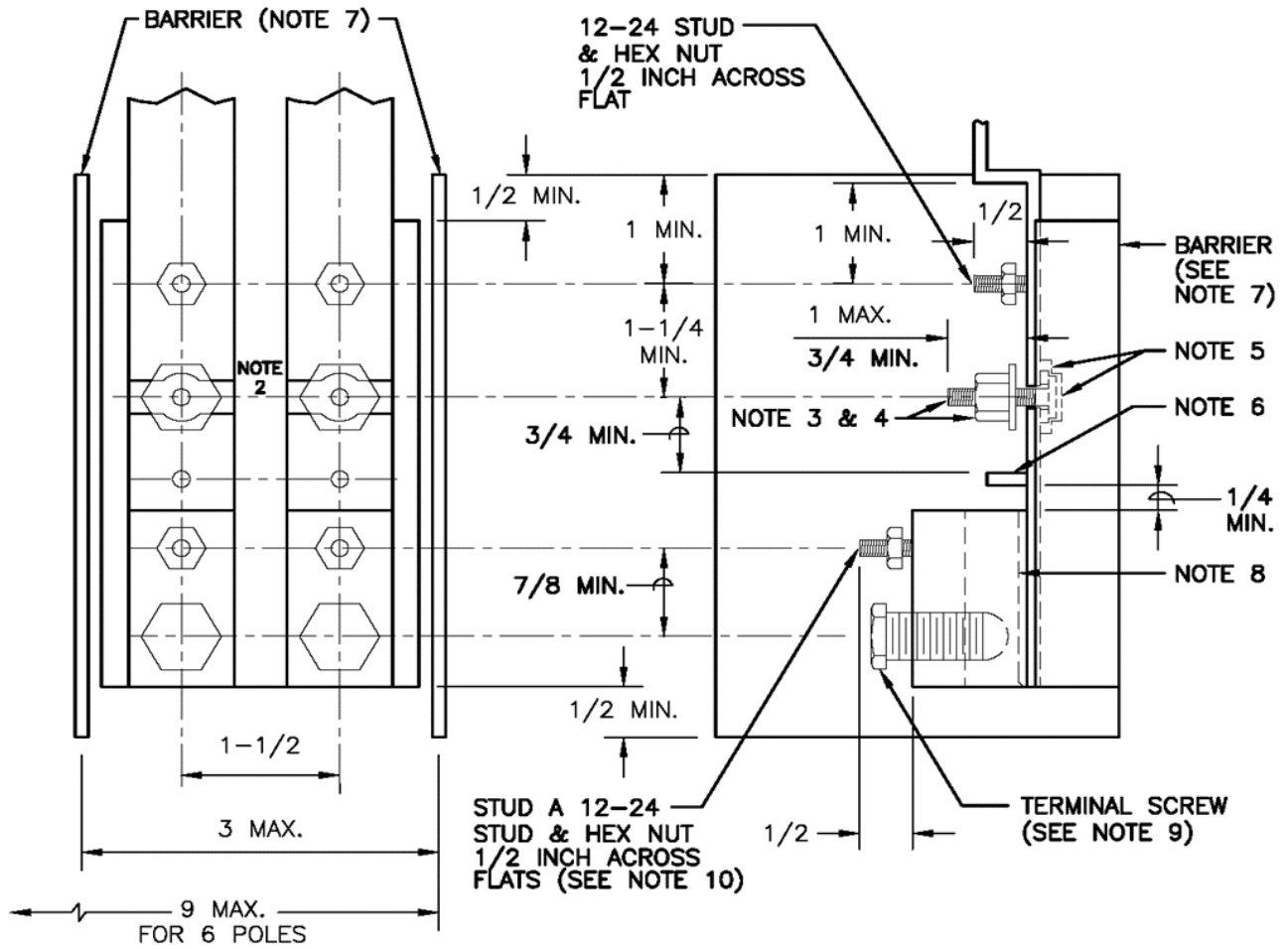

NOTES:

1. All designs must receive approval of the EUSER Committees prior to production.
2. Strike distance between upper and lower bus sections shall not be less than 1/4 inch when the circuit-closing nut is backed off.
3. Circuit-closing nut shall be a hex nut 5/8 inch across flats with plated copper washer attached and have threads counter-bored at bottom to facilitate re-installation. Bolt head shall be secured in place to prevent turning and backout.
4. The circuit-closing nut and bolt assembly shall maintain the applied contact pressure between the plated copper washer and the bus members of the test-bypass block.

ALL DIMENSIONS SHOWN ARE IN INCHES

RE	CHANGE	BY	DSGN	APPV	DATE	REV	CHANGE	BY	DSGN	APPV	DATE
A						D					
B						E					
C						F					

Indicates Latest Revision Completely Revised New Page Information Removed

SHEET
1 OF 2

EUSERC MANUAL

**TEST BYPASS/DISCONNECT BLOCK FOR SAFETY
SOCKETS 100 AND 200 AMPERES, 0-600 VOLTS**

SECTION
300
DRAWING
311

5. Insulating washer shall be made from dimensionally stable, nontracking material and shall provide a minimum of 1/8 inch creep distance between the bolt and the bus sections. Bus sections shall be plated.
6. Wire stops shall extend to center of terminal opening or beyond.
7. Rigid insulating barriers shall project at least 1/4 inch beyond any energized parts when the maximum wire size is installed.
8. Cable terminating facilities shall be aluminum bodied mechanical lugs (for required conductor range, see Dwgs, 304 and 305). The opening shall extend through the terminal body and, if wire hole is round, shall be chamfered as necessary to facilitate installation of the largest size wire.
9. The terminal screw may be of Allen type (3/16 inch across flats for 100 amp, 5/16 inch across flats for 200 amp).
10. Stud "A" may be located either on the terminal body, on the bus member between the circuit-closing nut and the wire stop, or incorporated as part of the wire stop.

RE	CHANGE	BY	DSGN	APPV	DATE	REV	CHANGE	BY	DSGN	APPV	DATE
A						D					
B						E					
C						F					

SHEET 2 OF 2	Indicates Latest Revision	<input checked="" type="checkbox"/> Completely Revised	<input type="checkbox"/> New Page	<input type="checkbox"/> Information Removed
	EUSERC MANUAL			
	TEST BYPASS/DISCONNECT BLOCK FOR SAFETY SOCKETS 100 AND 200 AMPERES, 0-600 VOLTS			

SECTION 300 DRAWING 311

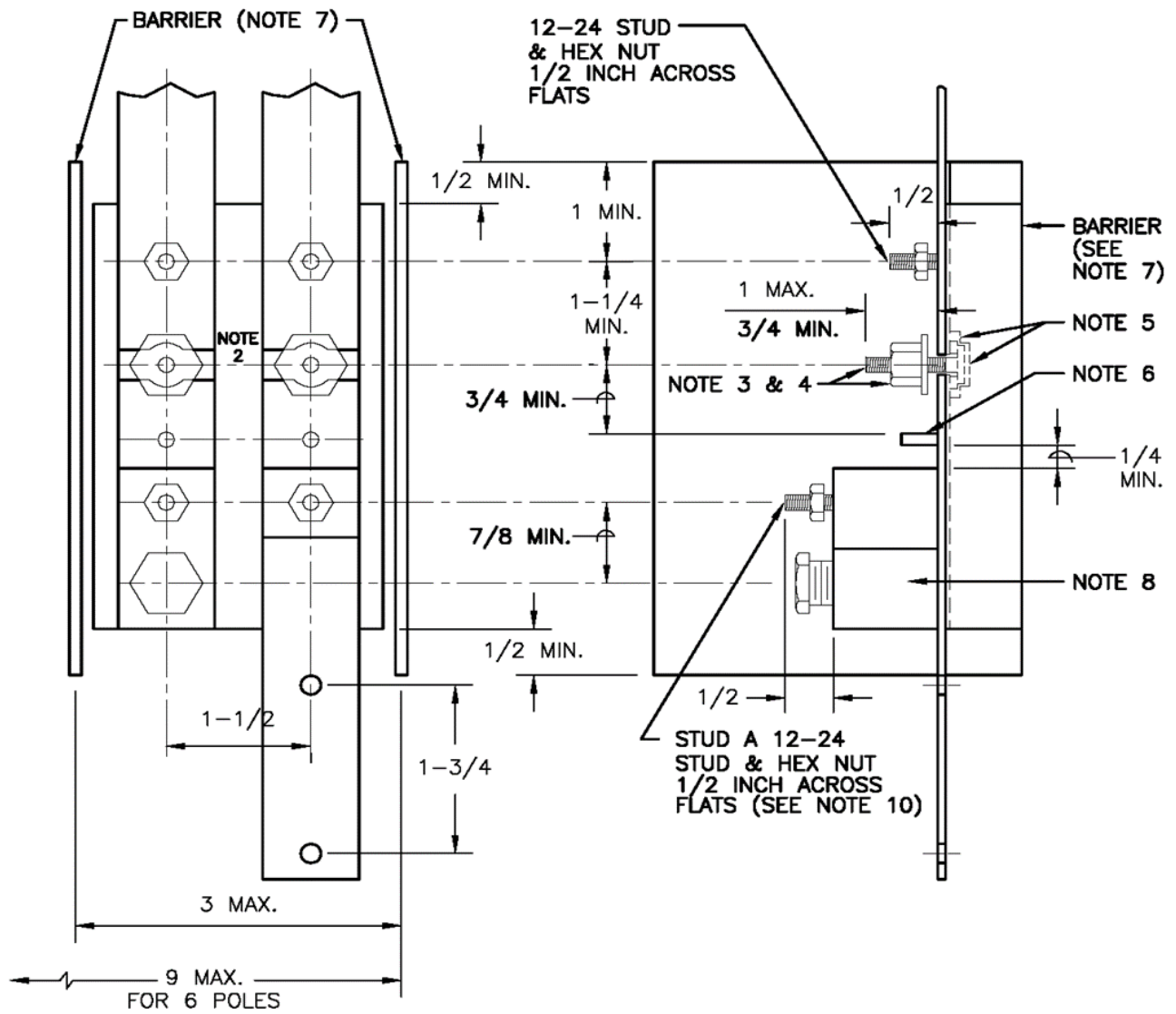

NOTES:

1. All designs must receive approval of the EUSER Committee prior to production.
2. Strike distance between upper and lower bus sections shall not be less than 1/4 inch when the circuit-closing nut is backed off.
3. Circuit-closing nut shall be a hex nut 5/8 inch across flats with plated copper washer attached and have threads counter-bored at bottom of facilitate re-installation. Bolt head shall be secured in place to prevent turning and backout.

ALL DIMENSIONS SHOWN ARE IN INCHES

RE	CHANGE	BY	DSGN	APPV	DATE	REV	CHANGE	BY	DSGN	APPV	DATE
A						D					
B						E					
C						F					

Indicates Latest Revision
 Completely Revised
 New Page
 Information Removed

SHEET
1 OF 2

EUSERC MANUAL
**TEST BYPASS/DISCONNECT BLOCK FOR SAFETY
 SOCKETS 100 AND 200 AMPERES, 0-600 VOLTS
 (BUSSED AND/OR CABLE TERMINATIONS)**

**SECTION
 300
 DRAWING
 312**

4. The circuit-closing nut and bolt assembly shall maintain the applied contact pressure between the plated copper washer and the bus members of the test-bypass block.
5. Insulating washer shall be made from dimensionally stable, nontracking material and shall provide a minimum of 1/8 inch creep distance between the bolt and the bus sections. Bus sections shall be plated.
6. Wire stops are not required if line and/or load is connected with bus bar. If cable terminals are used, Drawing 311 construction requirements shall apply.
7. Rigid insulating barriers shall project at least 1/4 inch beyond any energized parts when the maximum wire size is installed.
8. Terminals shall be aluminum bodied (for required conductor range, see Dwgs. 304 and 305). The opening shall extend through the terminal body and, if wire hole is round, shall be chamfered as necessary to facilitate installation of the largest size wire.
9. The terminal screw may be of Allen type (3/16 inch across flats for 100 amp, 5/16 inch across flats for 200 amp).
10. Stud "A" may be located either on the terminal body, on the bus member between the circuit-closing nut and the wire stop, or incorporated as part of the wire stop.

RE	CHANGE	BY	DSGN	APPV	DATE	REV	CHANGE	BY	DSGN	APPV	DATE
A						D					
B						E					
C						F					

SHEET 2 OF 2	Indicates Latest Revision	<input checked="" type="checkbox"/> Completely Revised	<input type="checkbox"/> New Page	<input type="checkbox"/> Information Removed
	EUSERC MANUAL			
	TEST BYPASS/DISCONNECT BLOCK FOR SAFETY SOCKETS 100 AND 200 AMPERES, 0-600 VOLTS (BUSSED AND/OR CABLE TERMINATIONS)			
SECTION 300 DRAWING 312				

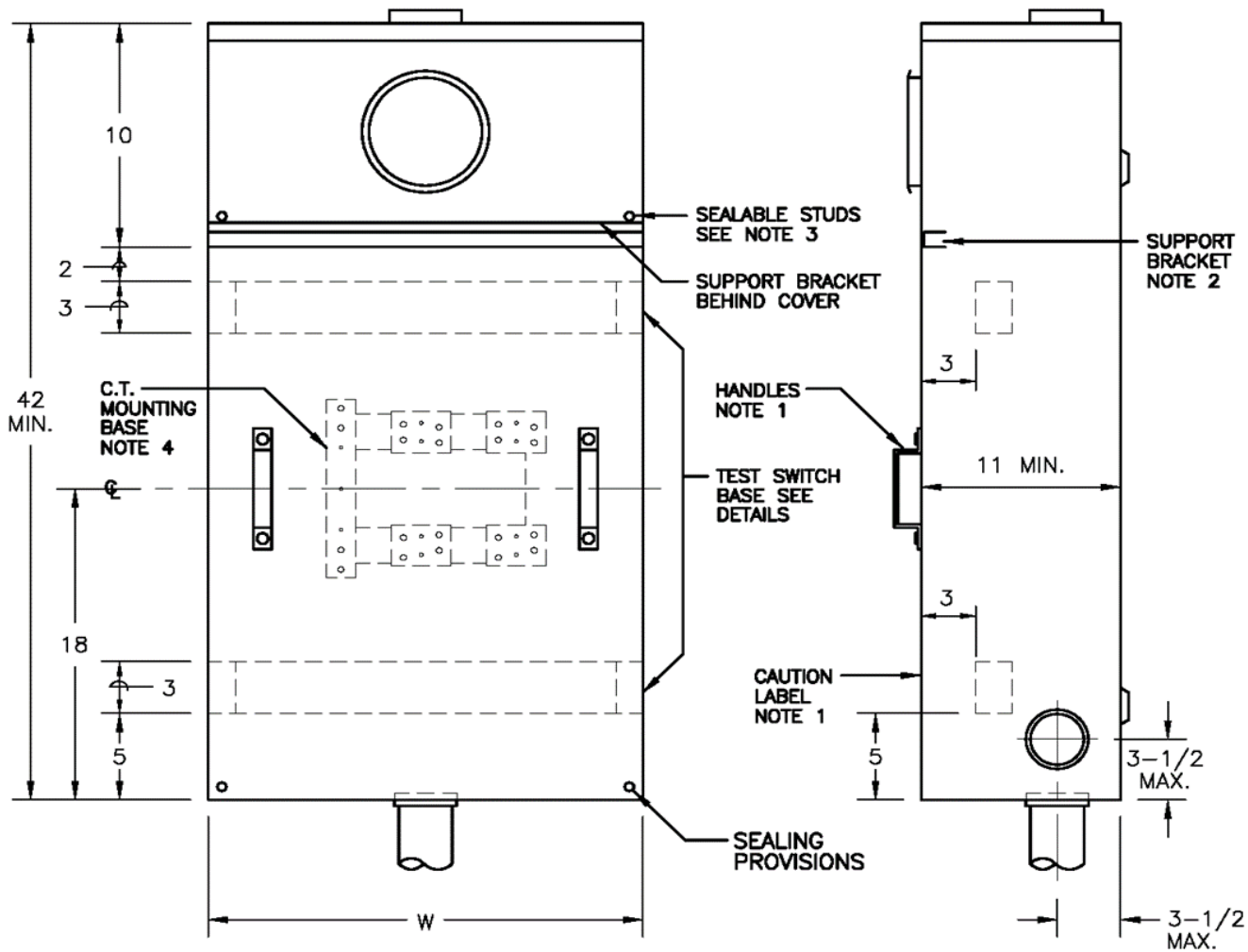

FRONT VIEW

SIDE VIEW

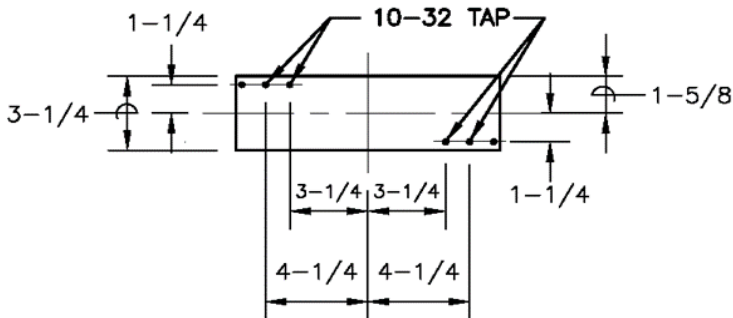

REMOVABLE TEST SWITCH MOUNTING BASE DETAIL

MINIMUM BOX DIMENSIONS

W (MIN.)	
3 PHASE, 4 WIRE WYE OR DELTA	SINGLE PHASE 3 PHASE, 3 WIRE
36"	24"

ALL DIMENSIONS SHOWN ARE IN INCHES

RE	CHANGE	BY	DSGN	APPV	DATE	REV	CHANGE	BY	DSGN	APPV	DATE
A						D					
B						E					
C						F					

Indicates Latest Revision
 Completely Revised
 New Page
 Information Removed

SHEET
1 OF 2

EUSERC MANUAL
**COMBINATION CURRENT-TRANSFORMER CABINET AND
 METER SOCKET PANEL FOR OVERHEAD SERVICE
 400-800 AMPERES, MAXIMUM 0-600 VOLT**

**SECTION
 300
 DRAWING
 313**

NOTES:

1. The current-transformer compartment cover panel(s) shall be limited to a maximum of 9 square feet in area, shall have two lifting handles and a caution label reading "DO NOT BREAK SEALS, NO FUSES INSIDE".
2. A panel support bracket shall be provided as shown for the meter and current transformer panels. The meter panel shall be attached to the bracket with securing screws to prevent the panel from pulling out when the meter is removed from the socket.
3. The meter panel and current transformer compartment cover shall be sealable. See Drawing 300, note 11(l).
4. See Drawings 328A, 328B and 329B for CT, mounting base details.
5. Consult the Utility for 800 ampere applications.

RE	CHANGE	BY	DSGN	APPV	DATE	REV	CHANGE	BY	DSGN	APPV	DATE
A						D					
B						E					
C						F					

SHEET 2 OF 2	Indicates Latest Revision	<input checked="" type="checkbox"/> Completely Revised	<input type="checkbox"/> New Page	<input type="checkbox"/> Information Removed	SECTION 300 DRAWING 313
	EUSERC MANUAL				
	COMBINATION CURRENT-TRANSFORMER CABINET AND METER SOCKET PANEL FOR OVERHEAD SERVICE 400-800 AMPERES, MAXIMUM 0-600 VOLT				

**APS ADDENDUM TO EUSERC REQUIREMENTS
PAGE 313/APS**

NOTES:

1. Device shown is allowable on Overhead Services only, unless Underground Termination Section is included.
2. Device must meet APS's available Fault Current requirements. See Section 800.



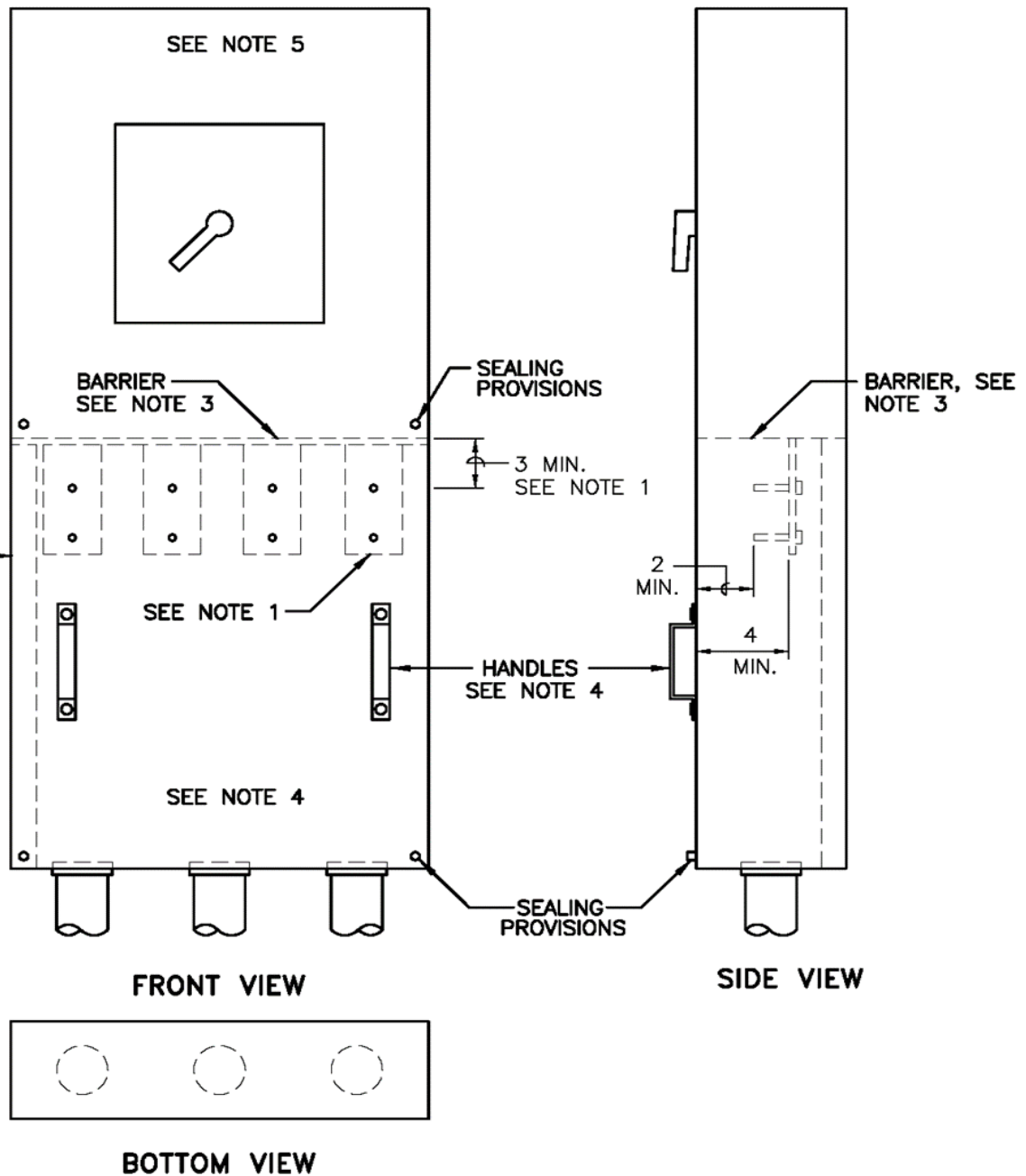

NOTES:

1. A vertical clearance of 3 inches minimum shall be maintained between the centerline of the top bolts of the terminating facilities to any obstruction. See Drawing 343 for terminating enclosure dimensions, and terminating facility clearances and construction details.

ALL DIMENSIONS SHOWN ARE IN INCHES

RE	CHANGE	BY	DSGN	APPV	DATE	REV	CHANGE	BY	DSGN	APPV	DATE
A						D					
B						E					
C						F					

Indicates Latest Revision
 Completely Revised
 New Page
 Information Removed

SHEET
1 OF 2

EUSERC MANUAL
**COMBINATION DISCONNECTING DEVICE AND
 TERMINATING ENCLOSURE 1200 AMPERES, 0-600 VOLT**

**SECTION
 300
 DRAWING
 315**

2. The grounding electrode conductor may be installed in a fully enclosed, factory installed wireway located in either back corner of the pullbox. The raceway shall not impede the serving utility's required working space or reduce any specified clearances.
3. A full width and depth, insulated, rigid barrier shall be provided to separate the termination and main disconnect device compartments.
4. Terminating enclosure covers shall be:
 - a. Independent of other equipment and removable without disturbing adjacent panels.
 - b. Sealable, and provided with two lifting handles, and limited to maximum of 9 square feet in area.
5. The main disconnect cover shall be sealable.

RE	CHANGE	BY	DSGN	APPV	DATE	REV	CHANGE	BY	DSGN	APPV	DATE
A						D					
B						E					
C						F					

SHEET 2 OF 2	Indicates Latest Revision	<input checked="" type="checkbox"/> Completely Revised	<input type="checkbox"/> New Page	<input type="checkbox"/> Information Removed	SECTION 300 DRAWING 315
	EUSERC MANUAL				
	COMBINATION DISCONNECTING DEVICE AND TERMINATING ENCLOSURE 1200 AMPERES, 0-600 VOLT				

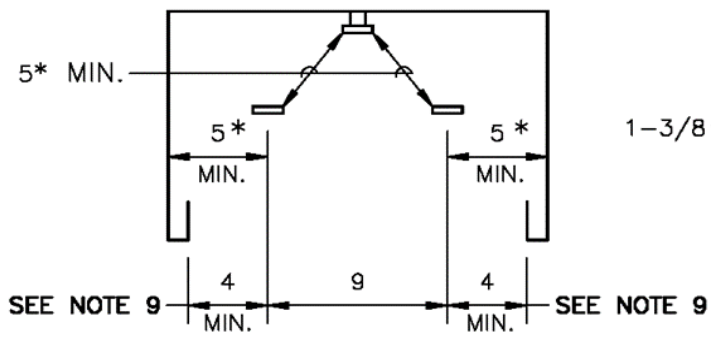

SEE NOTE 9 SEE NOTE 9

TOP VIEW

* SEE NOTE 6

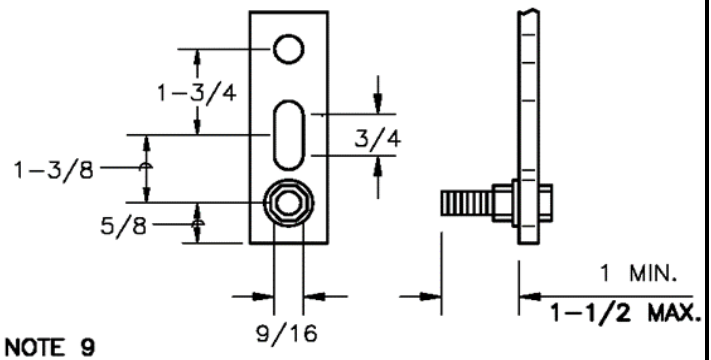

BUS DRILLING DETAIL
TYPICAL 4 LOCATIONS
SEE NOTE 3

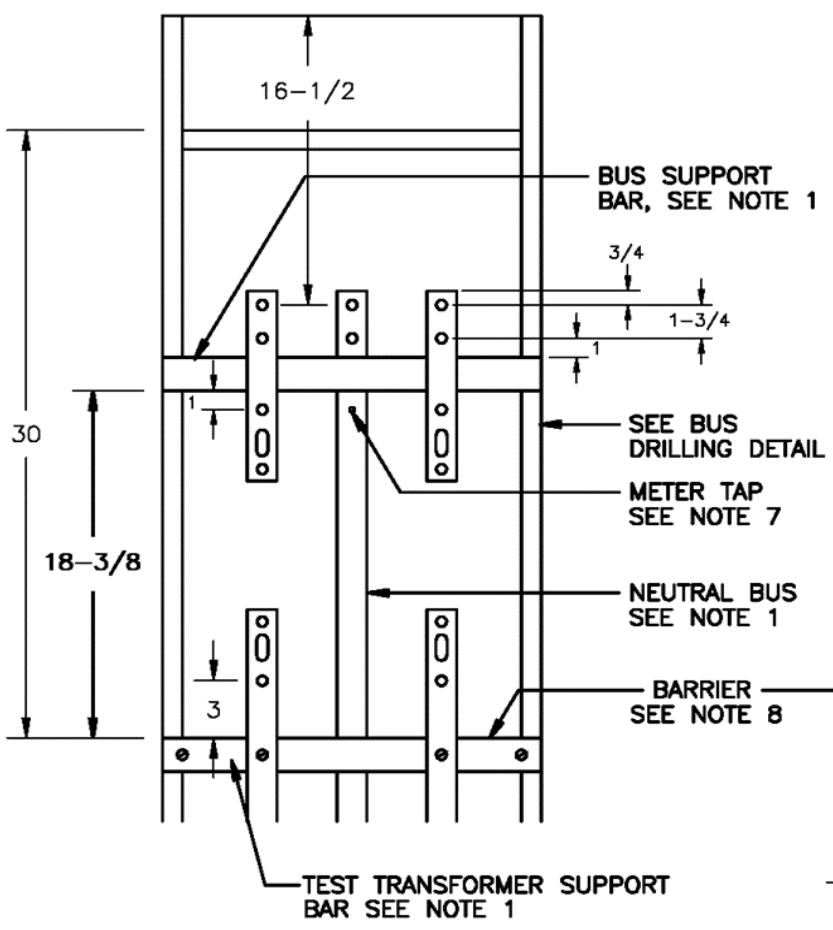

FRONT VIEW

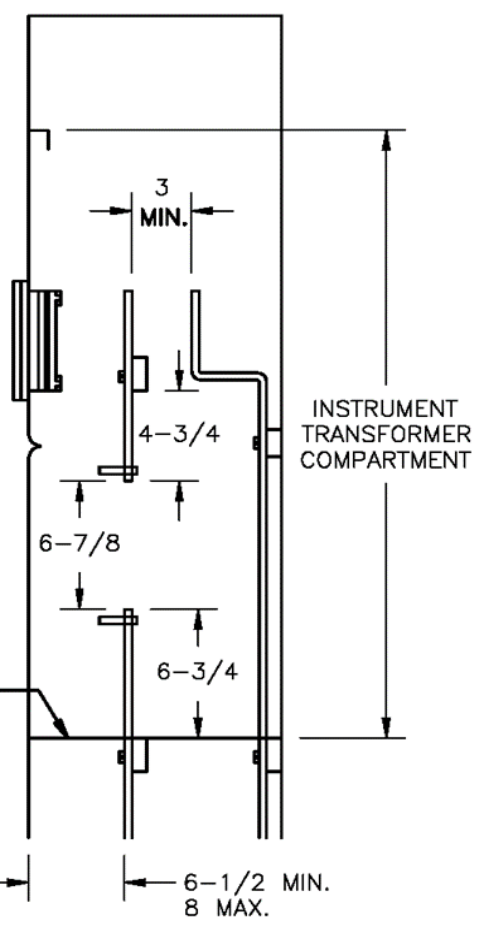

SIDE VIEW

ALL DIMENSIONS SHOWN ARE IN INCHES

RE	CHANGE	BY	DSGN	APPV	DATE	REV	CHANGE	BY	DSGN	APPV	DATE
A						D					
B						E					
C						F					

Indicates Latest Revision Completely Revised New Page Information Removed

SHEET
1 OF 2

EUSERC MANUAL
INSTRUMENT-TRANSFORMER COMPARTMENT FOR
SWITCHBOARDS 0-1000 AMPERES, 0-600 VOLTS,
SINGLE PHASE 3 WIRE AND 3 PHASE 3 WIRE

SECTION
300
DRAWING
319

NOTES:

1. Bus arrangement and supports shall be provided as shown, except the neutral bus may be located at either side or on either side wall. Bus supports shall be constructed of a continuous bar of insulating material and shall be rigid to prevent misalignment of the bus units with the cables in place.

2. The bus units may be supplied from the top or bottom, and shall be anchored to prevent turning. Bus units shall be constructed of rectangular bus and when laminated shall have no space between laminations. Bus dimensions shall be provided as follows:

Minimum: 1/4 inch X 2 inches
 Maximum: 3/4 inch X 2 inches

3. Bus unit shall be provided with a fixed stud as shown for mounting the current transformers. Each shall:

- a. Consist of a 1/2-inch steel bolt and shall be provided with a spring washer and a nut. The spring washer may be either a cone-type (belleville) washer or a split-ring washer and flat washer. All parts shall be plated to prevent corrosion.
- b. Be secured in place. "Secured in place" shall mean that the stud will not turn, back-out, or loosen in any manner when tightening or loosening the associated nuts (including cross-threaded situations).

4. When the compartment is supplied from horizontal cross-bussing, the bussing shall pass through the compartment or in the sealed area above the compartment.

5. Except for conductors supplying the instrument-transformer compartment, and the ground bus, no other conductors or devices shall be installed in, or routed through, the compartment or the sealed area above the compartment. The ground bus shall not infringe on utility compartment space, or reduce any clearances. Customer connections to the ground bus shall not be allowed in the instrument transformer compartment.

6. A clear unobstructed work space shall be provided around the current-transformer bus units from the barrier to the upper support bar.

7. Taps for attachment of meter wiring shall be provided on the neutral bus unit shown, or when the compartment is supplied from cross-bussing, a tap may be provided on the neutral cross-bus, or on a bus bar extension provided from the neutral cross-bus. A 10-32 screw and washer shall be provided for the neutral bus. Tap locations shall be centered between phase bus units, or at either side, and shall be readily accessible under energized conditions and with the current-transformers in place.

8. The barrier shall be constructed of a rigid insulating material resistant to ARC tracking, and shall be secured in place with a maximum deflection of 1/2 inch from an applied force of 25 pounds downward. Openings in the barrier (i.e., peripheral gaps around barrier, cutouts around bus bars, and hole diameters provided for ventilation) shall not exceed 3/8 inch. The barrier shall be attached with nonconductive fasteners.

9. Dimension measured to inside edge of the compartment access opening.

10. Torque labels shall be provided in each utility compartment where nut and bolt assemblies using cone-type (Belleville) washers are used for utility terminations, test-bypass block circuit closing nuts or for securing current-transformers or current transformer bus removable links. Labels shall be readily visible and shall not be installed on any removable or hinges cover panel.

RE	CHANGE	BY	DSGN	APPV	DATE	REV	CHANGE	BY	DSGN	APPV	DATE
A						D					
B						E					
C						F					

SHEET 2 OF 2	Indicates Latest Revision	<input checked="" type="checkbox"/> Completely Revised	New Page	Information Removed
	EUSERC MANUAL			
	INSTRUMENT-TRANSFORMER COMPARTMENT FOR SWITCHBOARDS 0-1000 AMPERES, 0-600 VOLTS, SINGLE PHASE 3 WIRE AND 3 PHASE 3 WIRE			
				SECTION 300 DRAWING 319

**APS ADDENDUM TO EUSERC REQUIREMENTS
PAGE 319/APS**

NOTES:

1. APS does not allow 3 Phase 3 Wire services.
2. Maximum allowable service for 1 Phase 3 Wire services is 800 Amp.



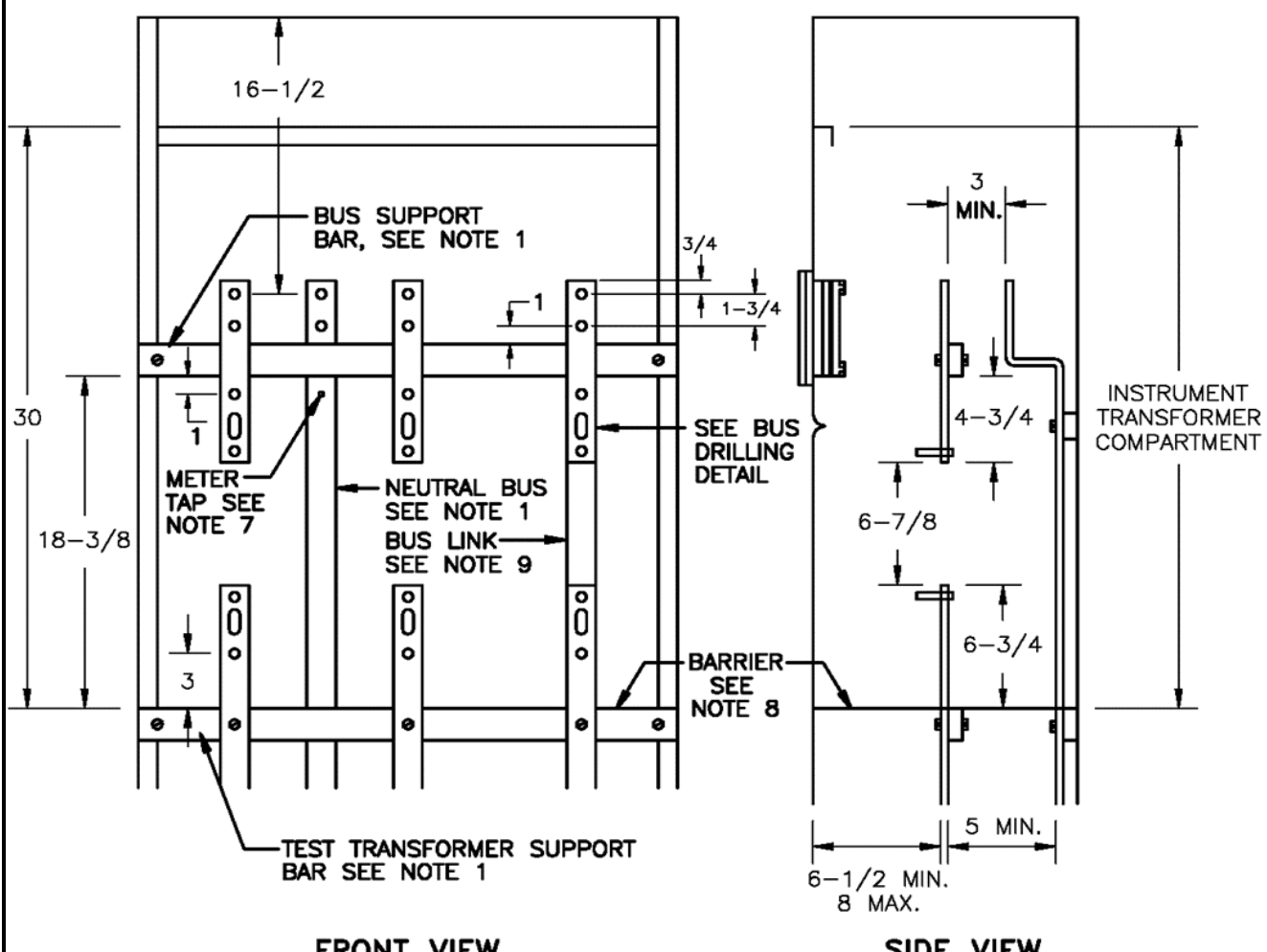
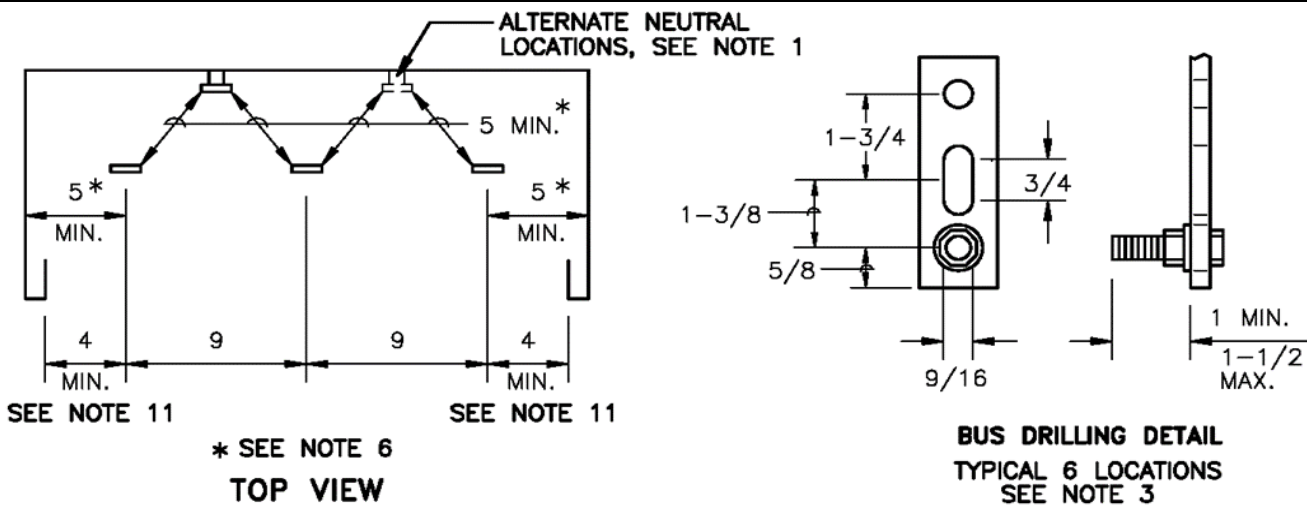

ALL DIMENSIONS SHOWN ARE IN INCHES

RE	CHANGE	BY	DSGN	APPV	DATE	REV	CHANGE	BY	DSGN	APPV	DATE
A	ADDED NOTE 13				05/18	D					
B						E					
C						F					

SHEET 1 OF 2	Indicates Latest Revision	<input checked="" type="checkbox"/> Completely Revised	<input type="checkbox"/> New Page	<input type="checkbox"/> Information Removed
	EUSERC MANUAL			
	INSTRUMENT-TRANSFORMER COMPARTMENT FOR SWITCHBOARDS 0-1000 AMPERES, 0-600 VOLTS, 3 PHASE 3 WIRE AND 4 WIRE			
SECTION 300 DRAWING 320				

NOTES:

1. Bus arrangement and supports shall be provided as shown, except the neutral bus may be located at either side or on either side wall (Note: neutral bus not required for 3-phase 3-wire service). Bus supports shall be constructed of a continuous bar of insulating material and shall be rigid to prevent misalignment of the bus units with the cables in place.
2. The bus units may be supplied from the top or bottom, and shall be anchored to prevent turning. Bus units shall be constructed of rectangular bus and when laminated shall have no space between laminations. Bus dimensions shall be provided as follows:
 Minimum: 1/4 inch X 2 inches
 Maximum: 3/4 inch X 2 inches
3. Bus unit shall be provided with a fixed stud as shown for mounting the current transformers. Each shall:
 - a. Consist of a 1/2-inch steel bolt and shall be provided with a spring washer and a nut. The spring washer may be either a cone-type (belleville) washer or a split-ring washer and flat washer. All parts shall be plated to prevent corrosion.
 - b. Be secured in place. "Secured in place" shall mean that the stud will not turn, back-out, or loosen in any manner when tightening or loosening the associated nuts (including cross-threaded situations).
4. When the compartment is supplied from horizontal cross-bussing, the bussing shall pass through the compartment or in the sealed area above the compartment.
5. Except for conductors supplying the instrument-transformer compartment, and the ground bus, no other conductors or devices shall be installed in, or routed through, the compartment or the sealed area above the compartment. The ground bus shall not infringe on utility compartment space, or reduce any clearances. Customer connections to the ground bus shall not be allowed in the instrument transformer compartment.
6. A clear unobstructed work space shall be provided around the current-transformer bus units from the barrier to the upper support bar.
7. Taps for attachment of meter wiring shall be provided on the neutral bus unit shown, or when the compartment is supplied from cross-bussing, a tap may be provided on the neutral cross-bus, or on a bus bar extension provided from the neutral cross-bus. A 10-32 screw and washer shall be provided for the neutral bus. Tap locations shall be centered between phase bus units, or at either side, and shall be readily accessible under energized conditions and with the current-transformers in place.
8. The barrier shall be constructed of a rigid insulating material resistant to ARC tracking, and shall be secured in place with a maximum deflection of 1/2 inch from an applied force of 25 pounds downward. Openings in the barrier (i.e., peripheral gaps around barrier, cutouts around bus bars, and hole diameters provided for ventilation) shall not exceed 3/8 inch. The barrier shall be attached with nonconductive fasteners.
9. A removable link shall be installed in the right side phase bus for 3-phase, 3-wire service.
10. The power leg bus for a 4-wire delta service shall be identified by an orange outer finish or by tagging or other effective means.
11. Dimension measured to inside edge of the compartment access opening.
12. Torque labels shall be provided in each utility compartment where nut and bolt assemblies using cone-type (Belleville) washers are used for utility terminations, test-bypass block circuit closing nuts or for securing current-transformers or current-transformer bus removable links. Labels shall be readily visible and shall not be installed on any removable or hinges cover panel.

RE	CHANGE	BY	DSGN	APPV	DATE	REV	CHANGE	BY	DSGN	APPV	DATE
A	ADDED NOTE 13				05/18	D					
B						E					
C						F					

SHEET 2 OF 2	Indicates Latest Revision	<input checked="" type="checkbox"/>	Completely Revised	<input type="checkbox"/>	New Page	<input type="checkbox"/>	Information Removed	SECTION 300 DRAWING 320
	EUSERC MANUAL							
	INSTRUMENT-TRANSFORMER COMPARTMENT FOR SWITCHBOARDS 0-1000 AMPERES, 0-600 VOLTS, 3 PHASE 3 WIRE AND 4 WIRE							

**APS ADDENDUM TO EUSERC REQUIREMENTS
PAGE 320/APS**

NOTES:

- 1. APS does not allow 3 Phase 3 Wire services.



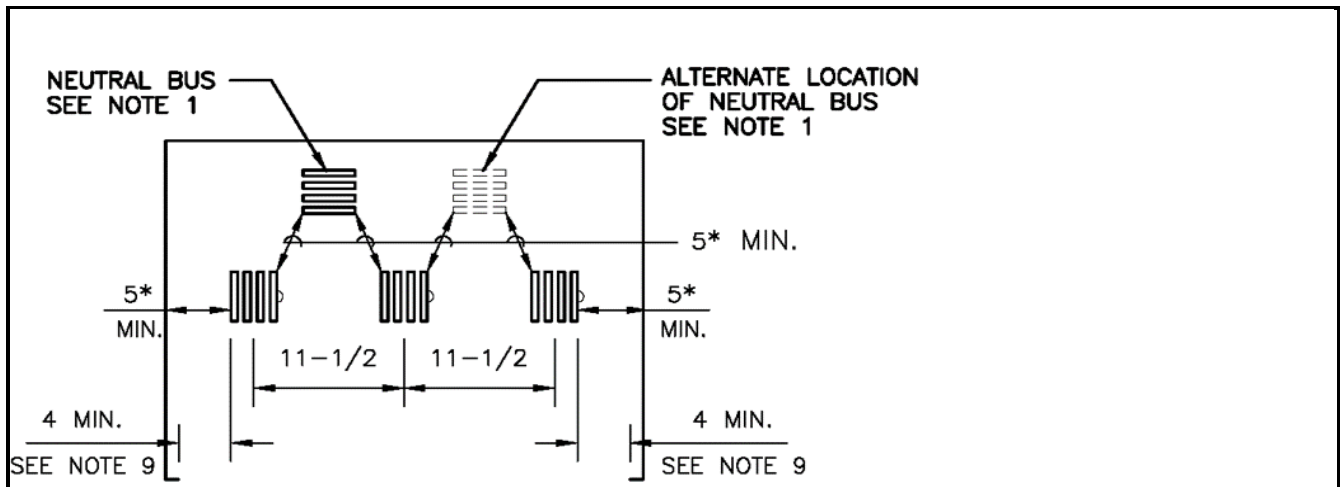

* SEE NOTE 6

TOP VIEW

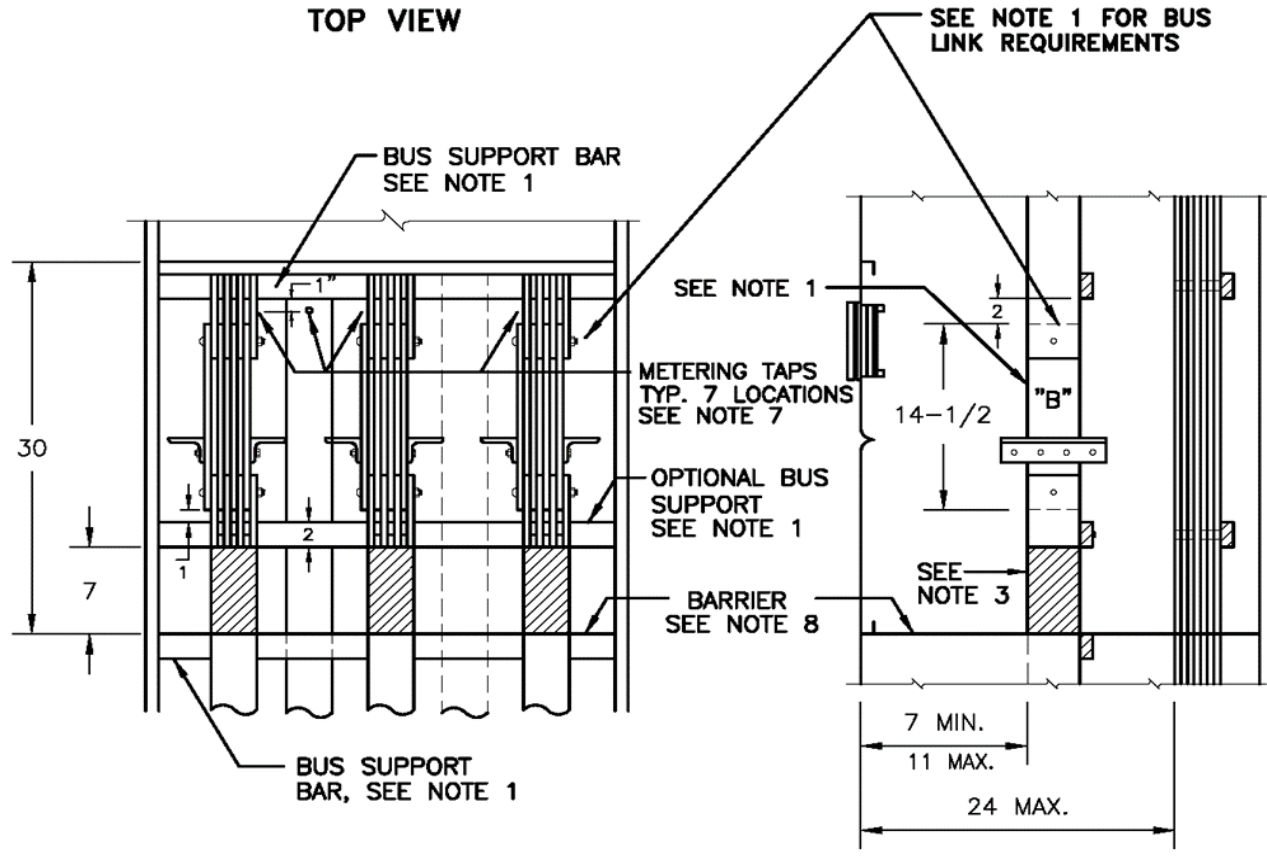

FRONT VIEW

SIDE VIEW

ALL DIMENSIONS SHOWN ARE IN INCHES

RE	CHANGE	BY	DSGN	APPV	DATE	REV	CHANGE	BY	DSGN	APPV	DATE
A						D					
B						E					
C						F					

Indicates Latest Revision Completely Revised New Page Information Removed

SHEET
1 OF 2

EUSERC MANUAL
**INSTRUMENT-TRANSFORMER COMPARTMENT FOR
 SWITCHBOARDS 1001-3000 AMPERES AND ABOVE, 0-600 VOLTS,
 THREE PHASE 3 WIRE AND 4 WIRE**

SECTION
300
DRAWING
322

NOTES:

1. Bus arrangements and supports shall be provided as shown, except the neutral bus may located at either side or on either side wall. (Note: neutral bus not required for 3-phase, 3-wire service). Bus units shall be anchored so that busses will remain in position when section "B" is removed. For details of section "B" and the insulated current-transformer support, see Drawing 330 and Drawing 331. Bus supports shall be constructed of a continuous bar of insulating material.
2. The bus units may be supplied from the top or bottom, and shall be constructed of rectangular bus. Maximum allowable bus size shall be four 1/4-inch x 4-inch bars spaced 1/4-inch.
3. Bus units shall be insulated as shown and the insulating material shall be rated for the serving voltage. Round bus corners as necessary to prevent damage to insulation.
4. When the compartment is supplied from horizontal cross-bussing, the bussing shall pass through the compartment or in the sealed area above the compartment.
5. Except for conductors supplying the instrument transformer compartment, and the ground bus, no other conductors or devices shall be installed in, or routed through, the compartment or the sealed area above the compartment. The ground bus shall not infringe on utility compartment space, or reduce any clearances. Customer connections to the ground bus shall not be allowed in the instrument transformer compartment.
6. A clear unobstructed work space shall be provided around the current-transformer bus units from the barrier to 2 inches above the removable current-transformer bus sections ("B").
7. A 10-32 tap for attachment of meter wiring shall be provided as follows:
 - a. One tap on each upper and lower phase bus unit with a 10-32 screw and washer provided for each phase bus in either the upper or lower position.
 - b. One tap on the neutral bus as shown, or when the compartment is supplied from cross-bussing, a tap may be provided on the neutral cross-bus, or on a bus bar extension provided from the neutral cross-bus. A 10-32 screw and washer shall be provided for the neutral bus. Tap locations shall be centered between phase bus units, or at either side, and shall be readily accessible under energized conditions and with the current-transformers in place.
8. The barrier shall be constructed of a rigid insulating material resistant to ARC tracking and shall be secured in place with a maximum deflection of 1/2 inch from an applied force of 25 pounds downward. Openings in the barrier (i.e., peripheral gaps around barrier, cutouts around bus bars, and hole diameters provided for ventilation) shall not exceed 3/8 inch. The barrier shall be attached with nonconductive fasteners.
9. Dimension measured to inside edge of the compartment access opening.

RE	CHANGE	BY	DSGN	APPV	DATE	REV	CHANGE	BY	DSGN	APPV	DATE
A						D					
B						E					
C						F					

SHEET 2 OF 2	Indicates Latest Revision	<input checked="" type="checkbox"/> Completely Revised	<input type="checkbox"/> New Page	<input type="checkbox"/> Information Removed
	EUSERC MANUAL			
	INSTRUMENT-TRANSFORMER COMPARTMENT FOR SWITCHBOARDS 1001-3000 AMPERES AND ABOVE, 0-600 VOLTS, THREE PHASE 3 WIRE AND 4 WIRE			

SECTION 300 DRAWING 322

**APS ADDENDUM TO EUSERC REQUIREMENTS
PAGE 322/APS**

NOTES:

1. APS does not allow 3 Phase 3 Wire services.



NEUTRAL BUS
SEE NOTE 1

ALTERNATE LOCATION
OF NEUTRAL BUS
SEE NOTE 1

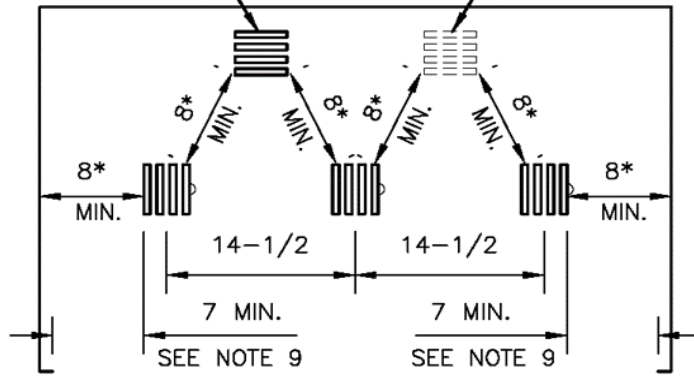
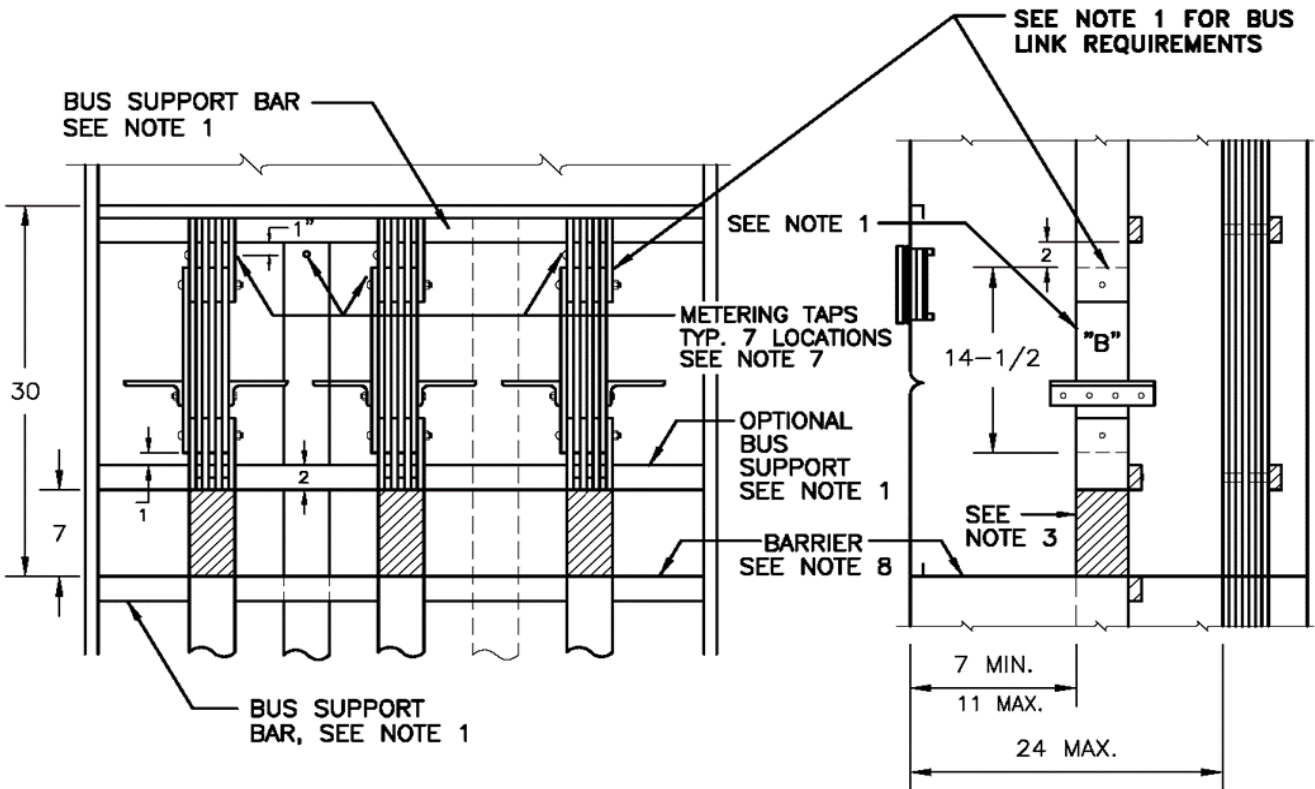

TABLE 1

MAXIMUM ALLOWABLE BUS			
FOUR	1/4 INCHx4 INCH	BARS SPACED 1/4	
SIX	1/4 INCHx5 INCH	BARS SPACED 1/4	
FIVE	3/8 INCHx5 INCH	BARS SPACED 3/8	

* SEE NOTE 6

TOP VIEW



FRONT VIEW

SIDE VIEW

ALL DIMENSIONS SHOWN ARE IN INCHES

RE	CHANGE	BY	DSGN	APPV	DATE	REV	CHANGE	BY	DSGN	APPV	DATE
A						D					
B						E					
C						F					

Indicates Latest Revision

Completely Revised

New Page

Information Removed

SHEET
1 OF 2

EUSERC MANUAL

INSTRUMENT-TRANSFORMER COMPARTMENT FOR
SWITCHBOARDS 3001 AMPERES AND ABOVE, 0-600 VOLTS,
THREE PHASE 3 WIRE AND 4 WIRE

SECTION
300
DRAWING
324

NOTES:

1. Bus arrangements and supports shall be provided as shown, except the neutral bus may be located at either side or on either side wall. (Note: neutral bus not required for 3-phase, 3-wire service). Bus units shall be anchored so that busses will remain in position when section "B" is removed. For details of section "B" and the insulated current-transformer support, see Drawing 330 for 4-inch and Drawing 331 for 5-inch bus. Consult serving agency for the use of bus larger than 5-inches. Bus supports shall be constructed of a continuous bar of insulating material.
2. The bus units may be supplied from the top or bottom, and shall be constructed of rectangular bus. For maximum allowable bus sizes, see Table 1.
3. Bus units shall be insulated as shown and the insulating material shall be rated for the serving voltage. Round bus corners as necessary to prevent damage to insulation.
4. When the compartment is supplied from horizontal cross-bussing, the bussing shall pass through the compartment or in the sealed area above the compartment.
5. Except for conductors supplying the instrument transformer compartment, and the ground bus, no other conductors or devices shall be installed in, or routed through, the compartment or the sealed area above the compartment. The ground bus shall not infringe on utility compartment space, or reduce any clearances. Customer connections to the ground bus shall not be allowed in the instrument transformer compartment.
6. A clear unobstructed work space shall be provided around the current-transformer bus units from the barrier to 2 inches above the removable current-transformer bus sections ("B").
7. A 10-32 tap for attachment of meter wiring shall be provided as follows:
 - a. One tap on each upper and lower phase bus unit with a 10-32 screw and washer provided for each phase bus in either the upper or lower position.
 - b. One tap on the neutral bus as shown, or when the compartment is supplied from cross-bussing, a tap may be provided on the neutral cross-bus, or on a bus bar extension provided from the neutral cross-bus. A 10-32 screw and washer shall be provided for the neutral bus. Tap locations shall be centered between phase bus units, or at either side, and shall be readily accessible under energized conditions and with the current-transformers in place.
8. The barrier shall be constructed of a rigid insulating material resistant to ARC tracking and shall be secured in place with a maximum deflection of 1/2 inch from an applied force of 25 pounds downward. Openings in the barrier (i.e., peripheral gaps around barrier, cutouts around bus bars, and hole diameters provided for ventilation) shall not exceed 3/8 inch. The barrier shall be attached with nonconductive fasteners.
9. Dimension measured to inside edge of the compartment access opening.

RE	CHANGE	BY	DSGN	APPV	DATE	REV	CHANGE	BY	DSGN	APPV	DATE
A						D					
B						E					
C						F					

SHEET 2 OF 2	<input type="checkbox"/> Indicates Latest Revision	<input checked="" type="checkbox"/> Completely Revised	<input type="checkbox"/> New Page	<input type="checkbox"/> Information Removed	SECTION 300 DRAWING 324
	EUSERC MANUAL				
	INSTRUMENT-TRANSFORMER COMPARTMENT FOR SWITCHBOARDS 3001 AMPERES AND ABOVE, 0-600 VOLTS, THREE PHASE 3 WIRE AND 4 WIRE				

**APS ADDENDUM TO EUSERC REQUIREMENTS
PAGE 324/APS**

NOTES:

1. APS does not allow 3 Phase 3 Wire services.



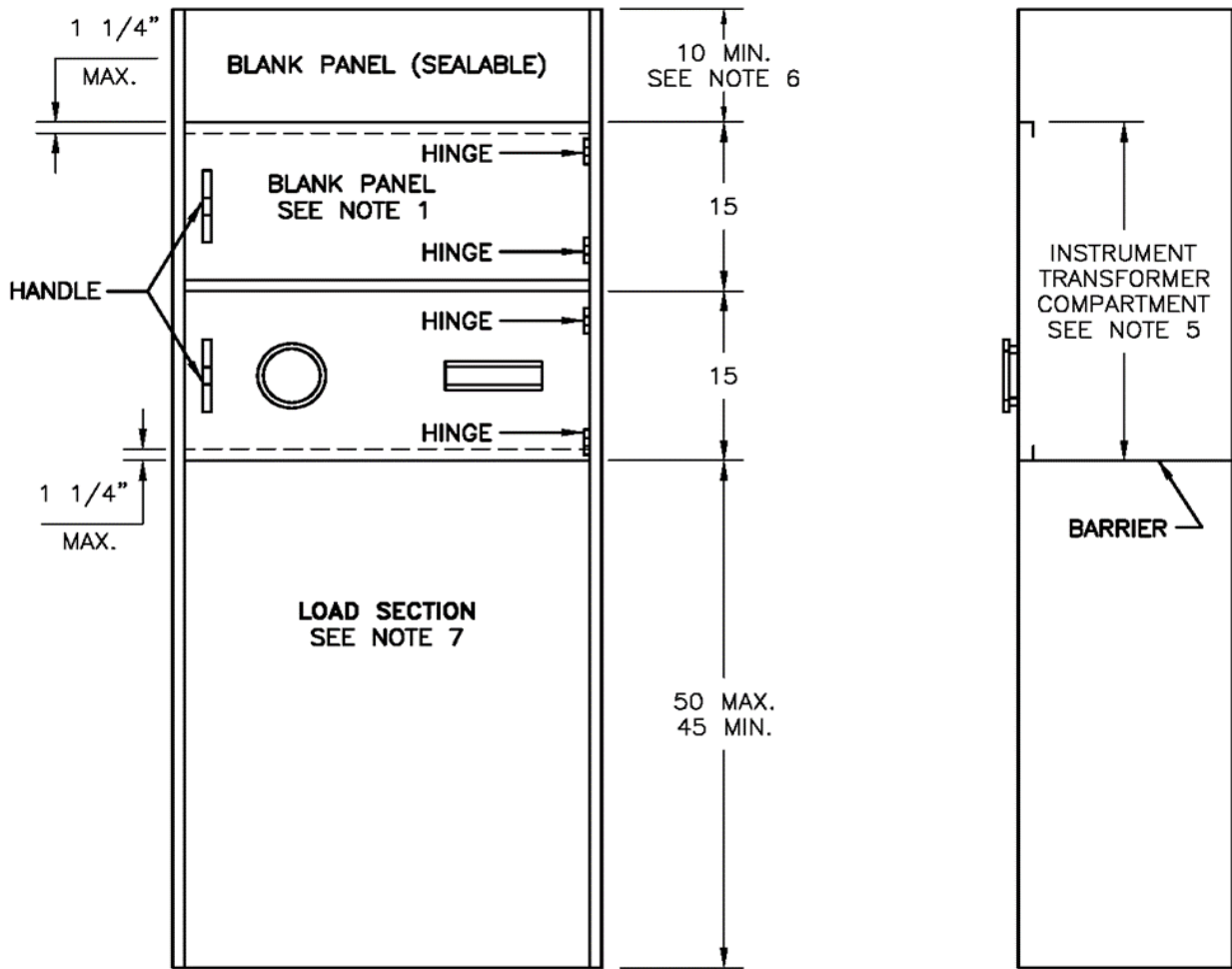

FRONT VIEW

SIDE VIEW

ALL DIMENSIONS SHOWN ARE IN INCHES

RE	CHANGE	BY	DSGN	APPV	DATE	REV	CHANGE	BY	DSGN	APPV	DATE
A						D					
B						E					
C						F					

Indicates Latest Revision
 Completely Revised
 New Page
 Information Removed

SHEET
1 OF 2

EUSERC MANUAL
**STANDARD SWITCHBOARD SERVICE SECTION WITH
 INSTRUMENT-TRANSFORMER COMPARTMENT 0-600 VOLTS**

**SECTION
 300
 DRAWING
 325**

NOTES:

1. Socket meter panel with blank meter panel shown. Consult serving utility regarding alternate meter panel arrangements. Blank meter panel shall be constructed of 12 gauge (minimum) steel. See Drawings 332, 333 and 336 for socket meter panel details.
2. Meter panels shall be equipped with stops to prevent inward swinging beyond the front surface of the service section.
3. Hinges shall be readily interchangeable, left or right, on the job site.
4. Removable or hinged panels enclosing unmetrated bus or cable shall be sealable. See drawing 300, note II(I).
5. For requirements regarding instrument-transformer compartments, see;
 - 0 to 1000 Amperes See Drawings 319, 320
 - 1001 to 3000 Amperes See Drawings 321, 322
 - 3001 Amperes and above See Drawings 323, 324
6. Dimension may be reduced if the service section is supplied from horizontal cross-bussing or bus duct.
7. When used as a utility terminating section in a bottom-fed service section, See Drawing 327.
8. For outdoor applications, See Drawing 354 for weatherproof enclosure requirements.

RE	CHANGE	BY	DSGN	APPV	DATE	REV	CHANGE	BY	DSGN	APPV	DATE
A						D					
B						E					
C						F					

SHEET 2 OF 2	Indicates Latest Revision	<input checked="" type="checkbox"/> Completely Revised	<input type="checkbox"/> New Page	<input type="checkbox"/> Information Removed
	EUSERC MANUAL			
	STANDARD SWITCHBOARD SERVICE SECTION WITH INSTRUMENT-TRANSFORMER COMPARTMENT 0-600 VOLTS			
				SECTION 300 DRAWING 325

**APS ADDENDUM TO EUSERC REQUIREMENTS
PAGE 325/APS**

NOTES:

1. Change note #1 to include: "APS requires the upper meter panel blank, and the lower meter panel drilled and cut per Dwg #332.
2. See Section 200, paragraph 201.1 and 201.2 for available services and restrictions.



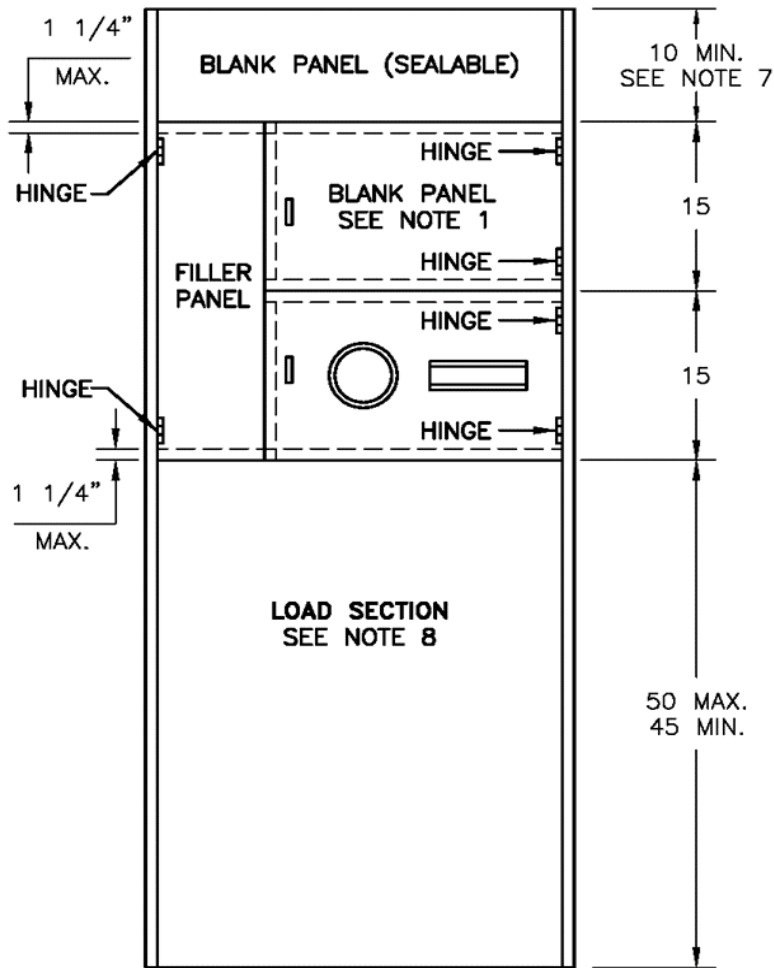

FRONT VIEW

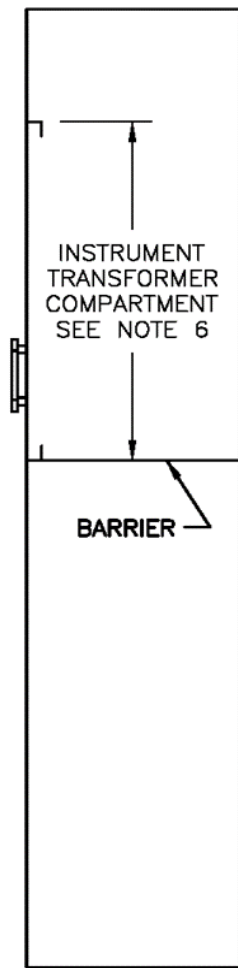

SIDE VIEW

ALL DIMENSIONS SHOWN ARE IN INCHES

RE	CHANGE	BY	DSGN	APPV	DATE	REV	CHANGE	BY	DSGN	APPV	DATE
A						D					
B						E					
C						F					

Indicates Latest Revision
 Completely Revised
 New Page
 Information Removed

SHEET
1 OF 2

EUSERC MANUAL
**STANDARD SWITCHBOARD SERVICE SECTION WITH
 INSTRUMENT-TRANSFORMER COMPARTMENT AND FILLER PANEL
 0-600 VOLTS**

**SECTION
 300
 DRAWING
 326**

NOTES:

1. Socket meter panel with blank meter panel shown. Consult serving utility regarding alternate meter panel arrangements. Blank meter panel shall be constructed of 12 gauge (minimum) steel. See Drawings 332, 333 and 336 for socket meter panel details.
2. Filler panels shall be used where the service section width exceeds the meter panel width. Meter panels, either socket or blank, shall not be hinged to hinged filler panels. Non-hinged filler panels shall not extend into the required instrument-transformer compartment access opening.
3. Meter panels and filler panels shall be equipped with stops to prevent inward swinging beyond the front surface of the service section.
4. Hinges shall be readily interchangeable, left or right, on the job site.
5. Removable or hinged panels enclosing unmetered bus or cable shall be sealable. See drawing 300, note II(I).
6. For requirements regarding instrument-transformer compartments, see;
 - 0 to 1000 Amperes See Drawings 319, 320
 - 1001 to 3000 Amperes See Drawings 321, 322
 - 3001 Amperes and above See Drawings 323, 324
7. Dimension may be reduced if the service section is supplied from horizontal cross-bussing or bus duct.
8. When used as a utility terminating section in a bottom-fed service section, See Drawing 327.
9. For outdoor applications, See Drawing 354 for weatherproof enclosure requirements.

RE	CHANGE	BY	DSGN	APPV	DATE	REV	CHANGE	BY	DSGN	APPV	DATE
A						D					
B						E					
C						F					

SHEET 2 OF 2	Indicates Latest Revision	<input checked="" type="checkbox"/> Completely Revised	<input type="checkbox"/> New Page	<input type="checkbox"/> Information Removed
	EUSERC MANUAL			
	STANDARD SWITCHBOARD SERVICE SECTION WITH INSTRUMENT-TRANSFORMER COMPARTMENT AND FILLER PANEL 0-600 VOLTS			
SECTION 300 DRAWING 326				

**APS ADDENDUM TO EUSERC REQUIREMENTS
PAGE 326/APS**

NOTES:

1. Change note #1 to include: "APS requires the upper meter panel blank, and the lower meter panel drilled and cut per Dwg #332.
2. See Section 200, paragraph 201.1 and 201.2 for available services and restrictions.



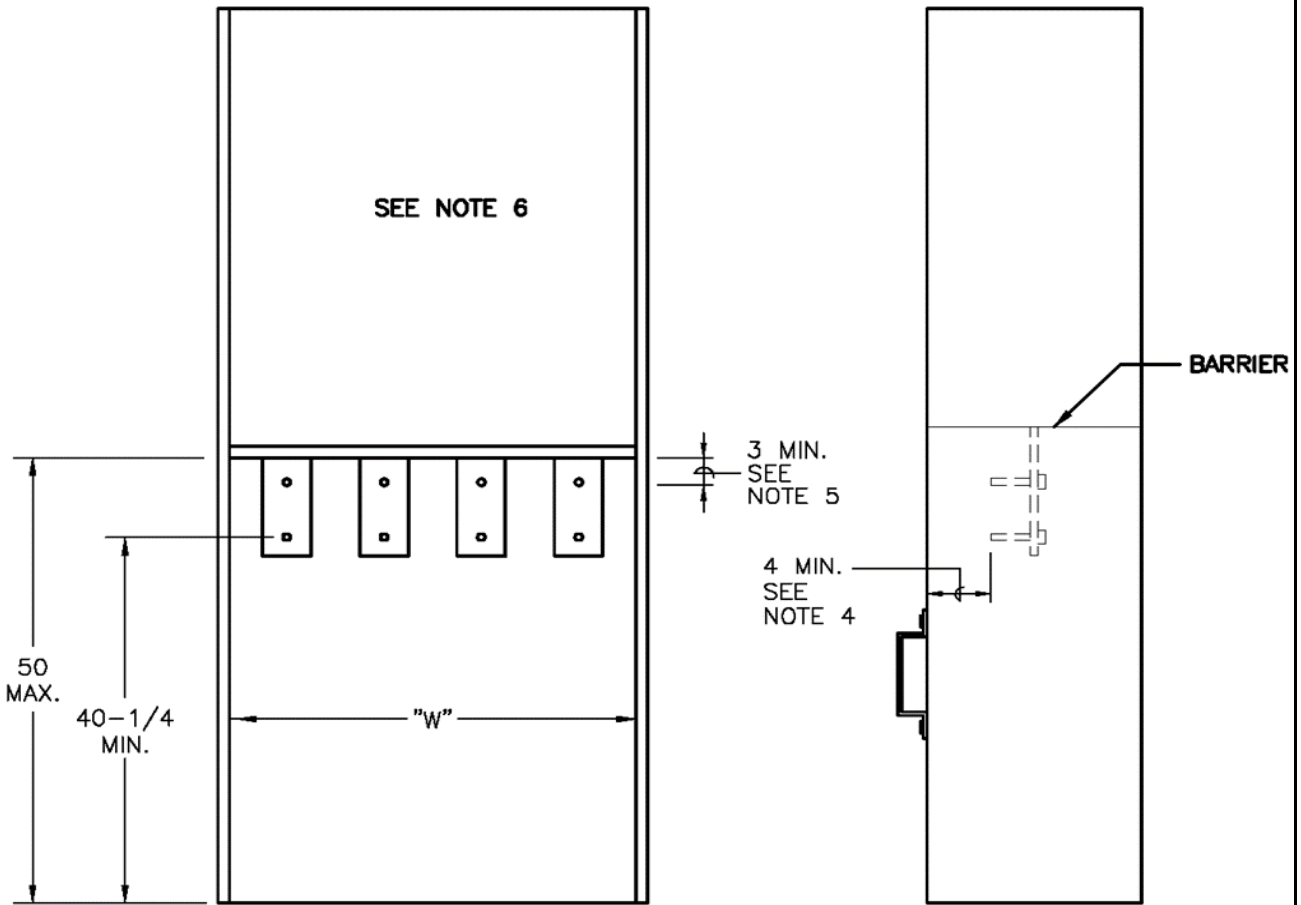

FRONT VIEW

SIDE VIEW

TABLE – MINIMUM DIMENSIONS

SWITCHBOARD RATING (AMPERES)	MINIMUM ACCESS OPENING DIMENSION (W) – SEE NOTE 8	
	3-WIRE	4-WIRE
BELOW 400	CONSULT SERVING AGENCY	
400 – 800	24	24
801 – 1200	24	30
1201 – 2000	30	35

NOTES:

1. The pull section may supply either a current-transformer compartment or a main service disconnect device.

ALL DIMENSIONS SHOWN ARE IN INCHES

RE	CHANGE	BY	DSGN	APPV	DATE	REV	CHANGE	BY	DSGN	APPV	DATE
A						D					
B						E					
C						F					

Indicates Latest Revision
 Completely Revised
 New Page
 Information Removed

SHEET
1 OF 2

EUSERC MANUAL
**COMBINATION SWITCHBOARD SERVICE SECTION AND
 PULL SECTION 0-600 VOLTS, 2000 AMPERES MAXIMUM**

**SECTION
 300
 DRAWING
 327**

2. Pull section covers shall be:
 - a. Independent of other equipment and removable without disturbing adjacent panels.
 - b. Sealable, provided with two lifting handles, and limited to a maximum of 9 square feet in area.
3. The panel shall be equipped with terminating facilities complying with Drawing 347. Terminating facilities shall be secured to prevent misalignment and shall be rigid without the installation of current-transformers.
4. The clearance from the energized bus to the pull section removable access covers may be reduced if a safety barrier is provided by the manufacturer. For additional clearance and barrier requirements, see Drawing 347, Note 12.
5. A vertical clearance of 3 inches minimum shall be maintained between the centerline of the top bolts of the terminating facilities to any obstruction.
6. When the upper section is:
 - a. An instrument-transformer compartment, see Drawings 325 and 326 for additional service section requirements.
 - b. A main service disconnect device.
 - (1) A full width and depth, insulated, rigid barrier shall be provided to separate the pull section and main service disconnect compartment.
 - (2) The main service disconnect cover shall be sealable.
7. Sealing provisions for removable covers shall consist of two drilled stud and wing-nut assemblies located on opposite sides of the cover. Hinged covers shall be sealed on the unsupported side. See drawing 300, note II(I).
8. The minimum pull section access opening (W) is measured between the left side and right side return flanges.

RE	CHANGE	BY	DSGN	APPV	DATE	REV	CHANGE	BY	DSGN	APPV	DATE
A						D					
B						E					
C						F					

SHEET 2 OF 2	Indicates Latest Revision	<input checked="" type="checkbox"/> Completely Revised	<input type="checkbox"/> New Page	<input type="checkbox"/> Information Removed	SECTION 300 DRAWING 327
	EUSERC MANUAL				
	COMBINATION SWITCHBOARD SERVICE SECTION AND PULL SECTION 0-600 VOLTS, 2000 AMPERES MAXIMUM				

**APS ADDENDUM TO EUSERC REQUIREMENTS
PAGE 327/APS**

NOTES:

1. Add note #6 (c): "Equipped with meter doors, APS requires the upper meter panel blank, and the lower meter panel drilled and cut per Dwg #332.
2. See Section 200, paragraph 201.1 and 201.2 for available services and restrictions.
3. Change Title bar to indicate device shown is acceptable up to a maximum of 3,000 amperes (Device must meet all other EUSERC and APS dimension requirements).



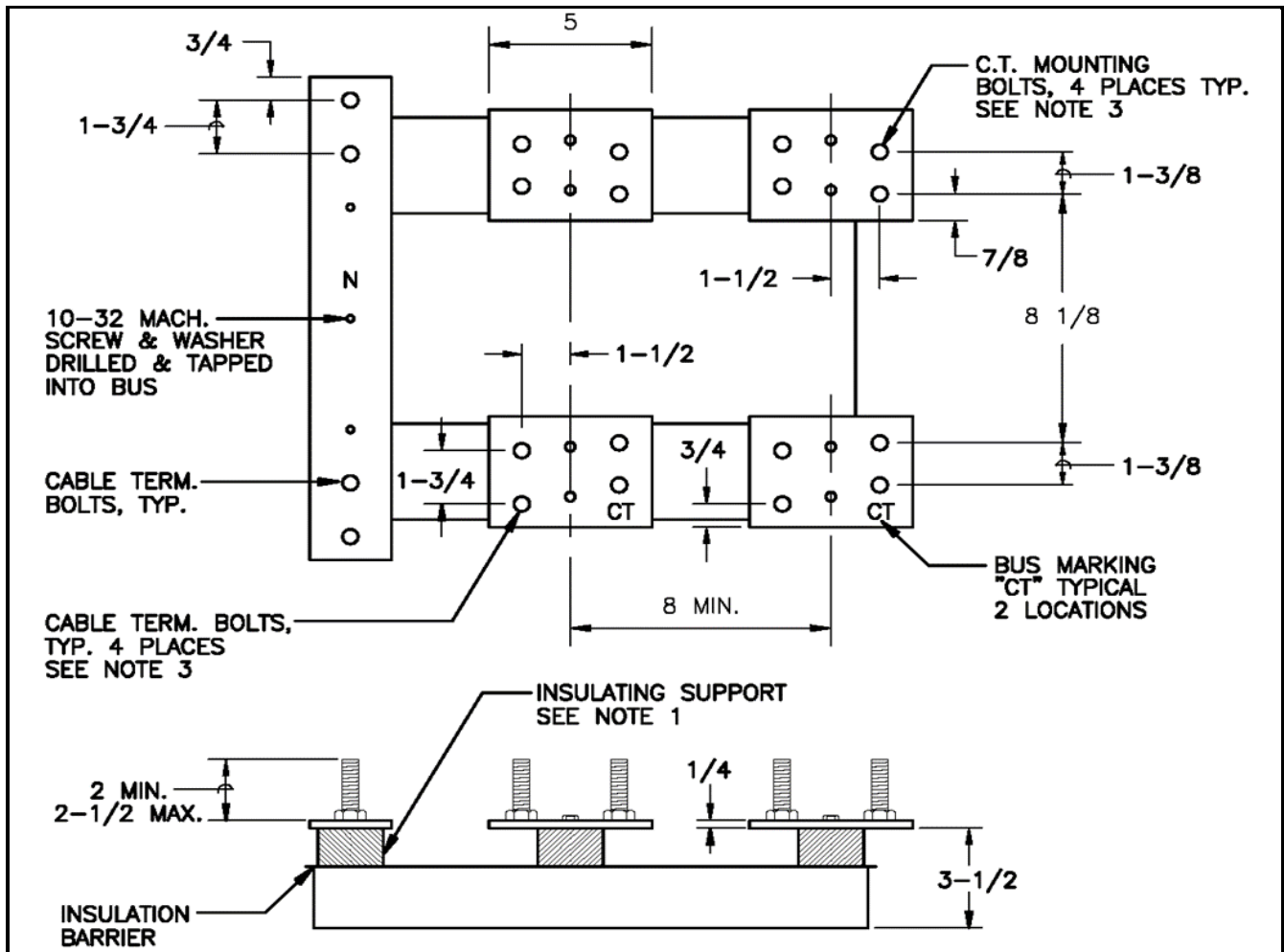

NOTES:

1. Insulated supports shall be rated for the serving voltage and have sufficient mechanical strength for the application.
2. Mounting base accepts bar type current transformers only.
3. Two 1/2 inch steel bolts shall be provided for each cable terminating and current-transformer mounting position. Each bolt shall be furnished with a spring washer and a nut. The spring washer may be either a cone-type (belleville) or a split-ring washer and a flat washer. Bolts shall be secured in place and spaced as shown. All parts shall be plated to prevent corrosion.
 "NOTE: When Belleville washers are used, the manufacturer shall provide a label with the required torque setting. This label shall be in a readily visible location within the compartment that the washers are being utilized and shall not be installed on the meter or filler panels".
4. For applications, see Drawings 313, 314 and 316.
5. Consult the serving utility for 800 ampere applications.

ALL DIMENSIONS SHOWN ARE IN INCHES

RE	CHANGE	BY	DSGN	APPV	DATE	REV	CHANGE	BY	DSGN	APPV	DATE
A						D					
B						E					
C						F					

<input type="checkbox"/> Indicates Latest Revision	<input checked="" type="checkbox"/> Completely Revised	<input type="checkbox"/> New Page	<input type="checkbox"/> Information Removed
--	--	-----------------------------------	--

SHEET
1 OF 1

EUSERC MANUAL

**CURRENT TRANSFORMER MOUNTING BASE
SINGLE PHASE OR THREE PHASE THREE WIRE
400-800 AMPERES MAXIMUM, 0-600 VOLTS**

**SECTION
300
DRAWING
328A**

**APS ADDENDUM TO EUSERC REQUIREMENTS
PAGE 328A/APS**

NOTES:

1. APS does not allow 3 Phase 3 Wire services.



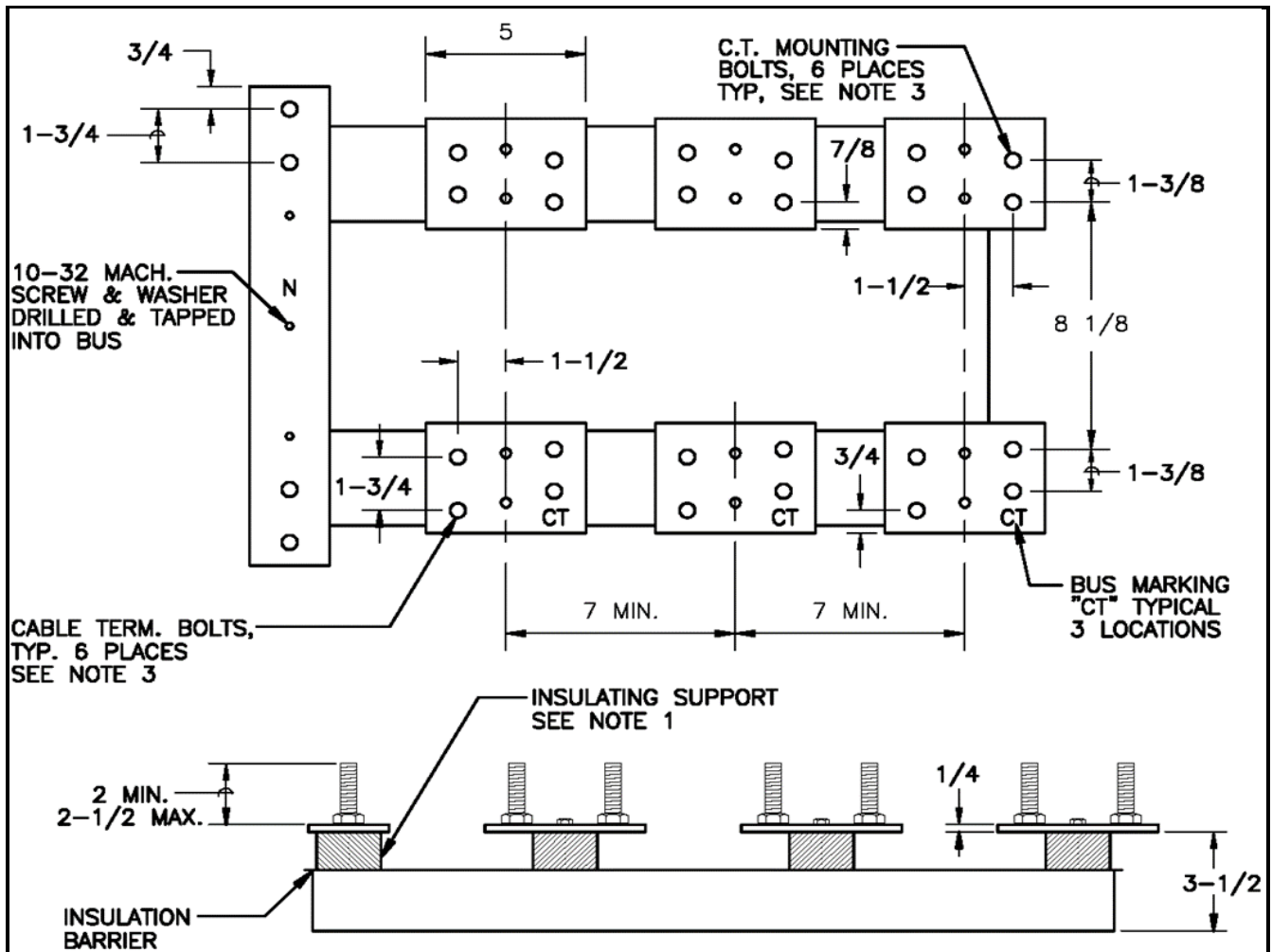

NOTES:

1. Insulated supports shall be rated for the serving voltage and have sufficient mechanical strength for the application.
2. Mounting base accepts bar type current transformers only.
3. Two 1/2 inch steel bolts shall be provided for each cable terminating and current-transformer mounting position. Each bolt shall be furnished with a spring washer and a nut. The spring washer may be either a cone-type (belleville) or a split-ring washer and a flat washer. Bolts shall be secured in place and spaced as shown. All parts shall be plated to prevent corrosion.
 "NOTE: When Belleville washers are used, the manufacturer shall provide a label with the required torque setting. This label shall be in a readily visible location within the compartment that the washers are being utilized and shall not be installed on the meter or filler panels."
4. For applications, see Drawings 313, 314 and 316.
5. Consult the serving utility for 800 ampere applications.

ALL DIMENSIONS SHOWN ARE IN INCHES

RE	CHANGE	BY	DSGN	APPV	DATE	REV	CHANGE	BY	DSGN	APPV	DATE
A						D					
B						E					
C						F					

SHEET 1 OF 1	Indicates Latest Revision	<input checked="" type="checkbox"/> Completely Revised	New Page	Information Removed
	EUSERC MANUAL			
	CURRENT TRANSFORMER MOUNTING BASE THREE PHASE THREE WIRE OR FOUR WIRE 400-800 AMPERES MAXIMUM, 0-600 VOLTS			

**SECTION
300
DRAWING
329A**

**APS ADDENDUM TO EUSERC REQUIREMENTS
PAGE 329A/APS**

NOTES:

1. APS does not allow 3 Phase 3 Wire services.



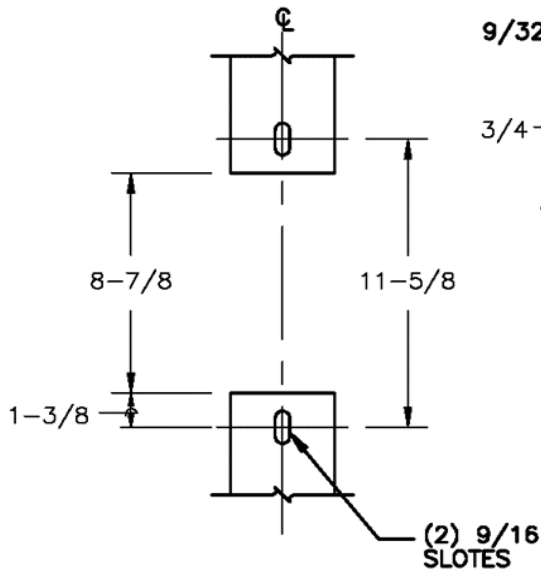

DETAIL 'A'
DRILLING AND SPACING OF BUS

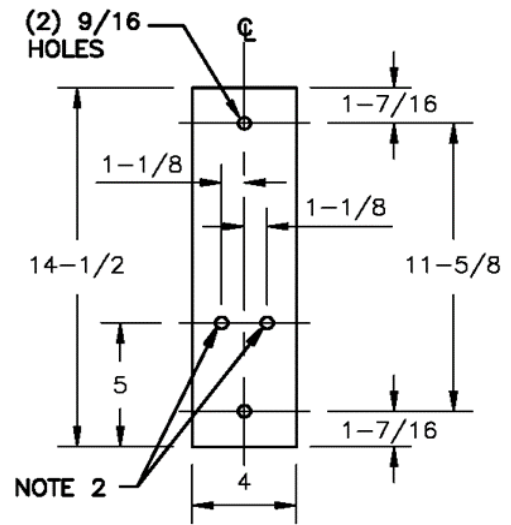

DETAIL 'B'
1/4x4 LINK
(SAME MATERIAL AS BUS)

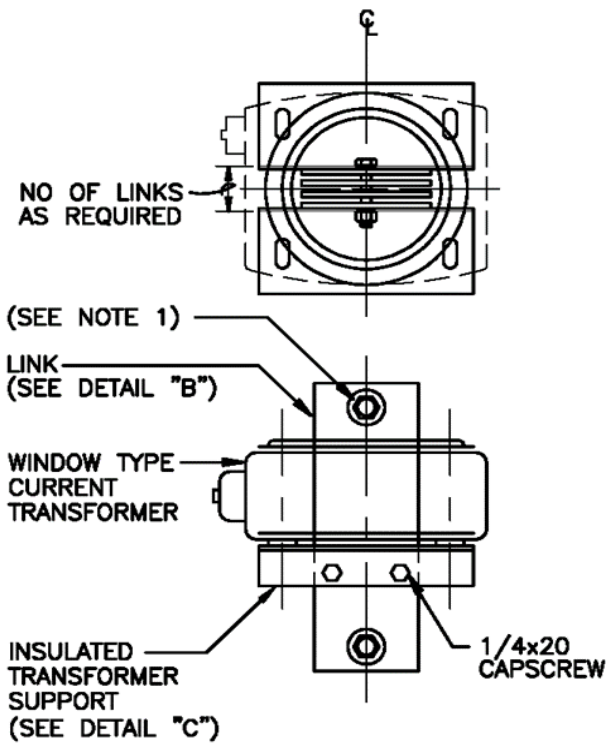

REMOVABLE LINK
(FURNISHED BY MANUFACTURER)

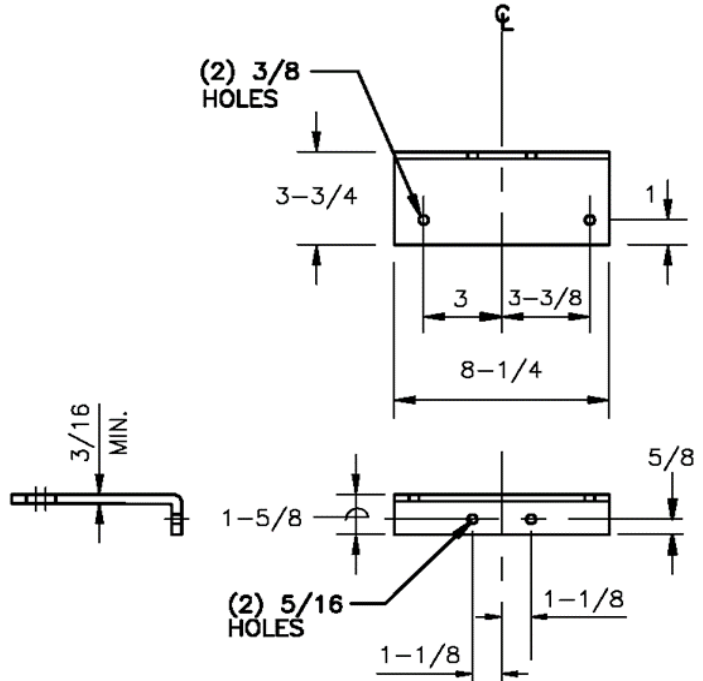

DETAIL 'C'
INSULATED SUPPORT FOR
CURRENT TRANSFORMER
(MATERIAL: INSULATING, NON-TRACKING)

ALL DIMENSIONS SHOWN ARE IN INCHES

RE	CHANGE	BY	DSGN	APPV	DATE	REV	CHANGE	BY	DSGN	APPV	DATE
A						D					
B						E					
C						F					

Indicates Latest Revision

Completely Revised

New Page

Information Removed

SHEET
1 OF 2

EUSERC MANUAL

REMOVABLE LINK AND CURRENT TRANSFORMER SUPPORT
FOR INSTRUMENT TRANSFORMER COMPARTMENTS WITH 4-INCH
BUS, 0-600 VOLTS

SECTION
300
DRAWING
330

NOTES:

1. Manufacturer shall secure the removable bus link to the upper and lower current transformer bus units using 1/2-inch hex-head (grade 5) steel bolts with associated washers and nut. Each bolt shall be provided with a flat washer, a spring washer and a nut. Spring washer may be either a cone-type (belleville) washer or a split-ring washer with a flat washer. All washers (belleville or flat) shall be 2-1/4 inches minimum.
 "Note: When belleville washers are used, the manufacturer shall provide a label with the required torque setting. This label shall be in a readily visible location within the compartment that the washers are being utilized and shall not be installed on the meter or filler panels."
2. Drill and tap two holes as shown on the outer bus units for 1/4-inch x 20 capscrews.

RE	CHANGE	BY	DSGN	APPV	DATE	REV	CHANGE	BY	DSGN	APPV	DATE
A						D					
B						E					
C						F					

SHEET 2 OF 2	Indicates Latest Revision	<input checked="" type="checkbox"/> Completely Revised	<input type="checkbox"/> New Page	<input type="checkbox"/> Information Removed
	EUSERC MANUAL			
	REMOVABLE LINK AND CURRENT TRANSFORMER SUPPORT FOR INSTRUMENT TRANSFORMER COMPARTMENTS WITH 4-INCH BUS, 0-600 VOLTS			
SECTION 300 DRAWING 330				

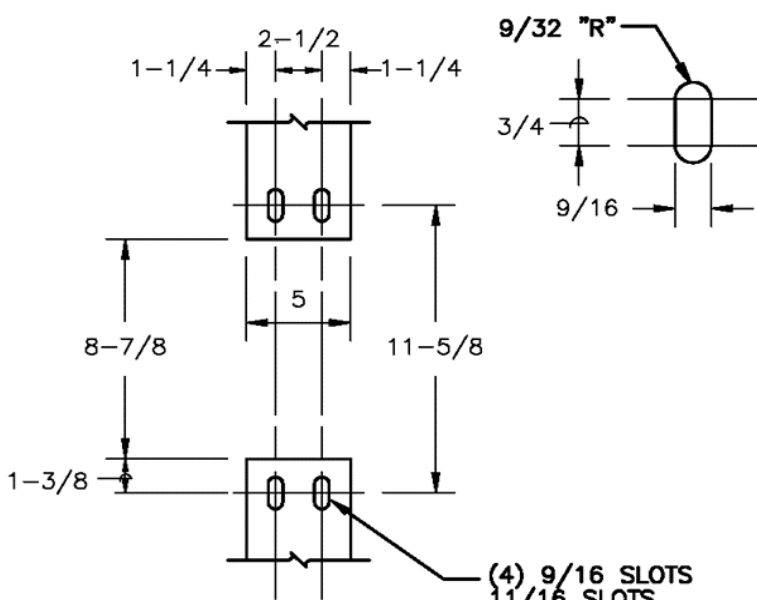

DETAIL 'A'
DRILLING AND SPACING OF BUS

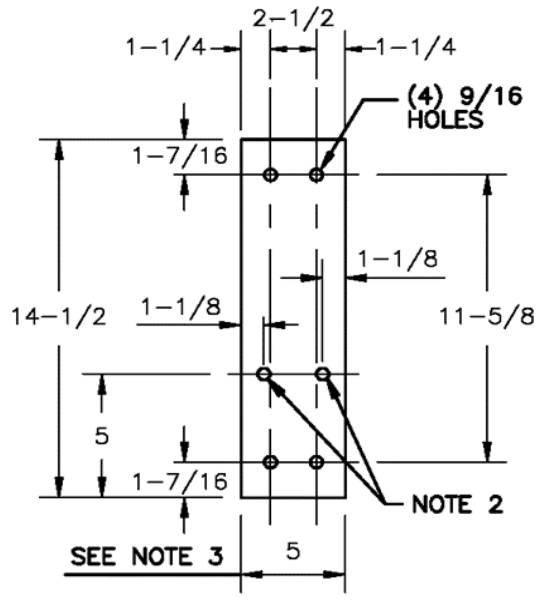

DETAIL 'B'
1/4x5 LINK
(SAME MATERIAL AS BUS)

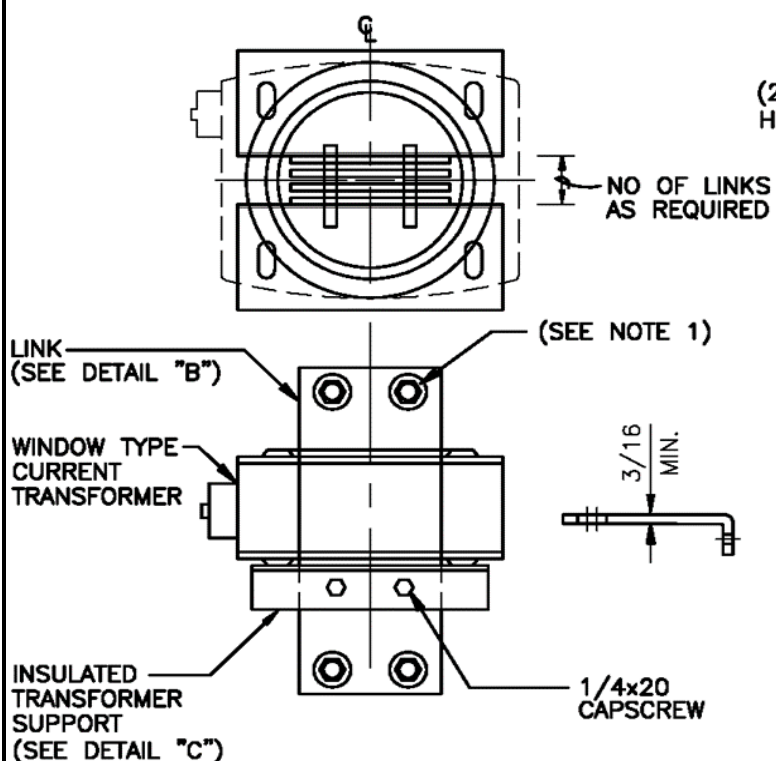

REMOVABLE LINK
(FURNISHED BY MANUFACTURER)

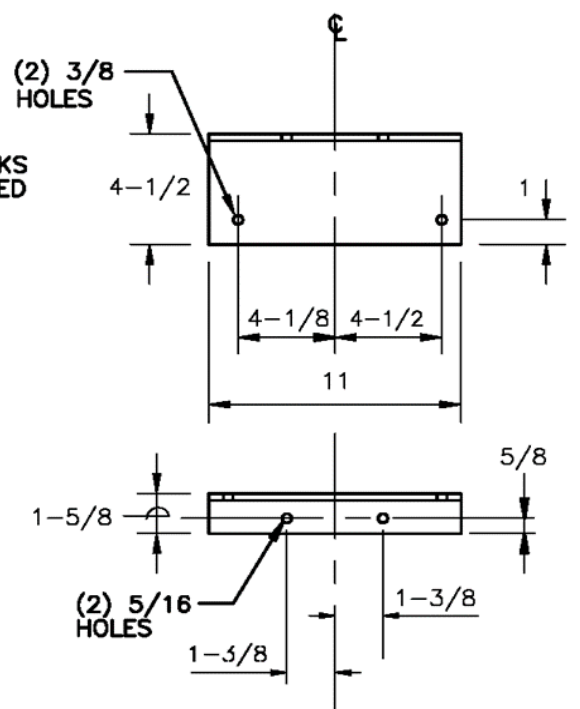

DETAIL 'C'
INSULATED SUPPORT FOR
CURRENT TRANSFORMER
(MATERIAL: INSULATING, NON-TRACKING)

ALL DIMENSIONS SHOWN ARE IN INCHES

RE	CHANGE	BY	DSGN	APPV	DATE	REV	CHANGE	BY	DSGN	APPV	DATE
A						D					
B						E					
C						F					

SHEET 1 OF 2	Indicates Latest Revision	<input checked="" type="checkbox"/> Completely Revised	<input type="checkbox"/> New Page	<input type="checkbox"/> Information Removed
	EUSERC MANUAL			
	REMOVABLE LINK AND CURRENT TRANSFORMER SUPPORT FOR INSTRUMENT TRANSFORMER COMPARTMENTS WITH 5-INCH BUS, 0-600 VOLTS			

**SECTION
300
DRAWING
331**

NOTES:

1. Manufacturer shall secure the removable bus link to the upper and lower current transformer bus units using 1/2-inch hex-head (grade 5) steel bolts. Each bolt shall be provided with two belleville washers installed on opposite sides of the bus units and a nut. Use of belleville washers requires a label on each phase of the bus link assembly indicating proper torque setting.
 "Note: When Belleville washers are used, the manufacturer shall provide a label with the required torque setting. This label shall be in a readily visible location within the compartment that the washers are being utilized and shall not be installed on the meter or filler panels."
2. Drill and tap two holes as shown on the outer bus units for 1/4-inch x 20 capscrews.
3. Consult the serving agency for use of bus bars larger than 5 inches.

RE	CHANGE	BY	DSGN	APPV	DATE	REV	CHANGE	BY	DSGN	APPV	DATE
A						D					
B						E					
C						F					

SHEET 2 OF 2	Indicates Latest Revision	<input checked="" type="checkbox"/> Completely Revised	New Page	Information Removed	SECTION 300 DRAWING 331
	EUSERC MANUAL				
	REMOVABLE LINK AND CURRENT TRANSFORMER SUPPORT FOR INSTRUMENT TRANSFORMER COMPARTMENTS WITH 5-INCH BUS, 0-600 VOLTS				

NOTES:

1. The panel shall be constructed of 12 gauge (minimum) steel and shall be hinged at the test switch side by the manufacturer. The panel shall be furnished with a meter socket, sealing ring, and a slotted opening and removable plate for the installation of a secondary test switch. The slotted opening and removable plate edges shall be smooth to prevent damage to meter wiring.

Note: When a cast meter mounting ring is provided, the screws used to attach to the meter panel shall provide a minimum 1/8-inch clearance between the screw heads and the back of the ring.

2. The removable plate shall be attached to the rear of the panel with screws that do not protrude through the face of the panel.
3. The meter socket shall be designed for back connection.
4. The panel shall be equipped with hinges. The hinges shall permit the panel to open to 90-degrees, and shall be easily interchangeable, right or left, on the meter socket panel. Removable pin type hinges are required, the pin shall be removable from the top.
5. The panel shall be equipped with a handle on the unsupported end. The handle shall be interchangeable, right or left, on the meter socket panel and maintain a 1-inch (minimum) clearance from the meter socket flange and slotted opening.
6. The panel shall support a 25-pound load applied at the unsupported end when fully opened with a maximum sag of 1/8 inch.
7. Stud and wing nut assemblies shall be sealable when used.
8. See Section 200 for correct meter socket configuration.
9. Test switch mounting holes shall be located on the top left and bottom right for safety.

RE	CHANGE	BY	DSGN	APPV	DATE	REV	CHANGE	BY	DSGN	APPV	DATE
A						D					
B						E					
C						F					

SHEET 2 OF 2	Indicates Latest Revision	<input checked="" type="checkbox"/> Completely Revised	<input type="checkbox"/> New Page	<input type="checkbox"/> Information Removed
	EUSERC MANUAL			
	15 INCH HINGED METER PANEL, 0-600 VOLTS			
SECTION 300 DRAWING 332				

APS ADDENDUM TO EUSERC DWG 332

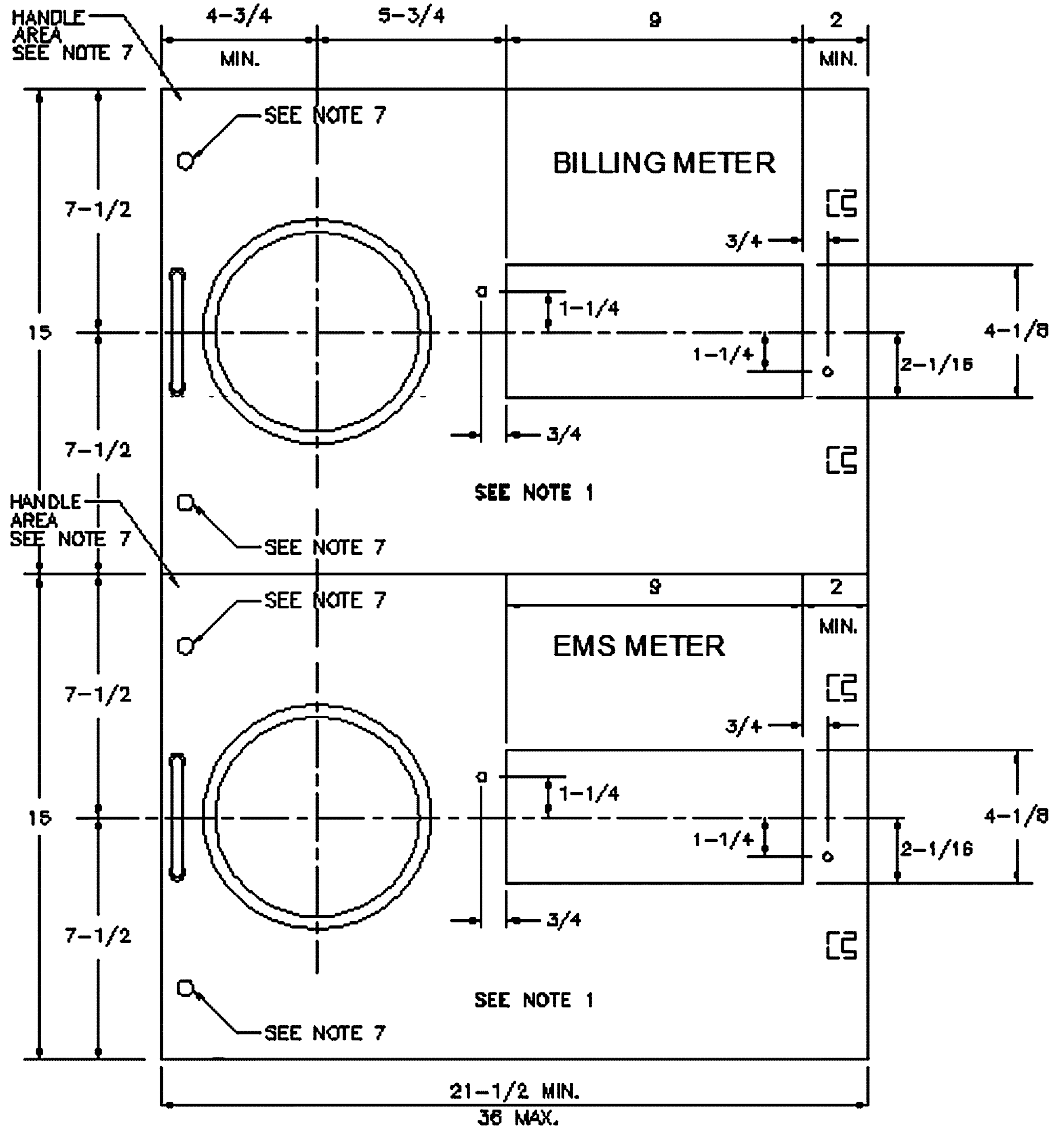

**(2) 15-INCH HINGED METER PANEL
0 - 15000 VOLTS**

GENERAL NOTES:

- A. Refer to sheet 1 of 2 and 2 of 2 of the EUSERC 332 drawing for test switch dimensions, test switch mounting information, and applicable notes.
- B. This diagram shall be used for applications requiring a second meter socket in order to meet APS requirements for large scale (utility scale) Generating Facility (e.g. Photovoltaic).
- C. Prior to applying this standard, check with the appropriate APS Representative.

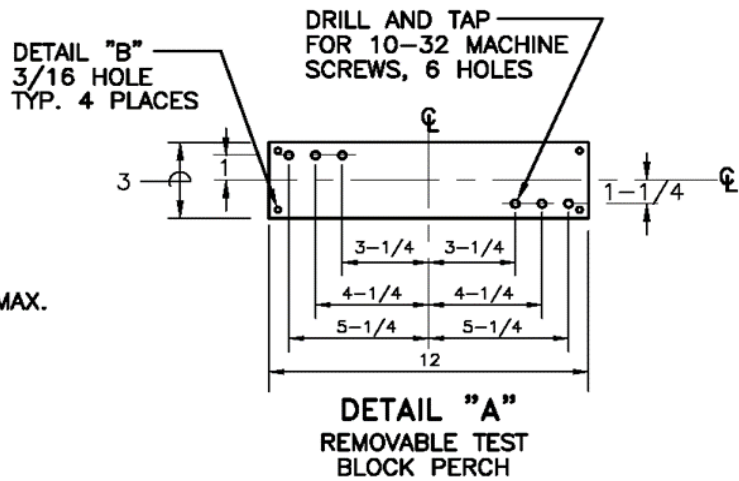
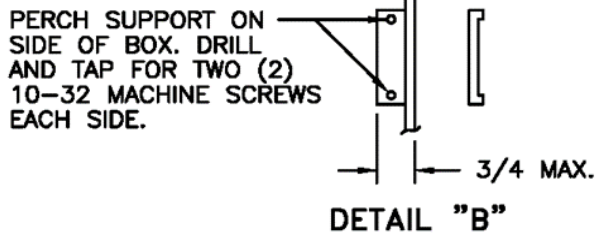
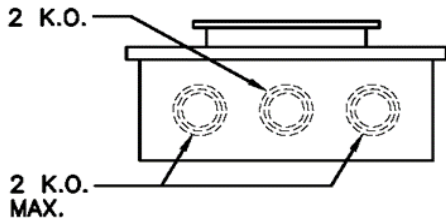
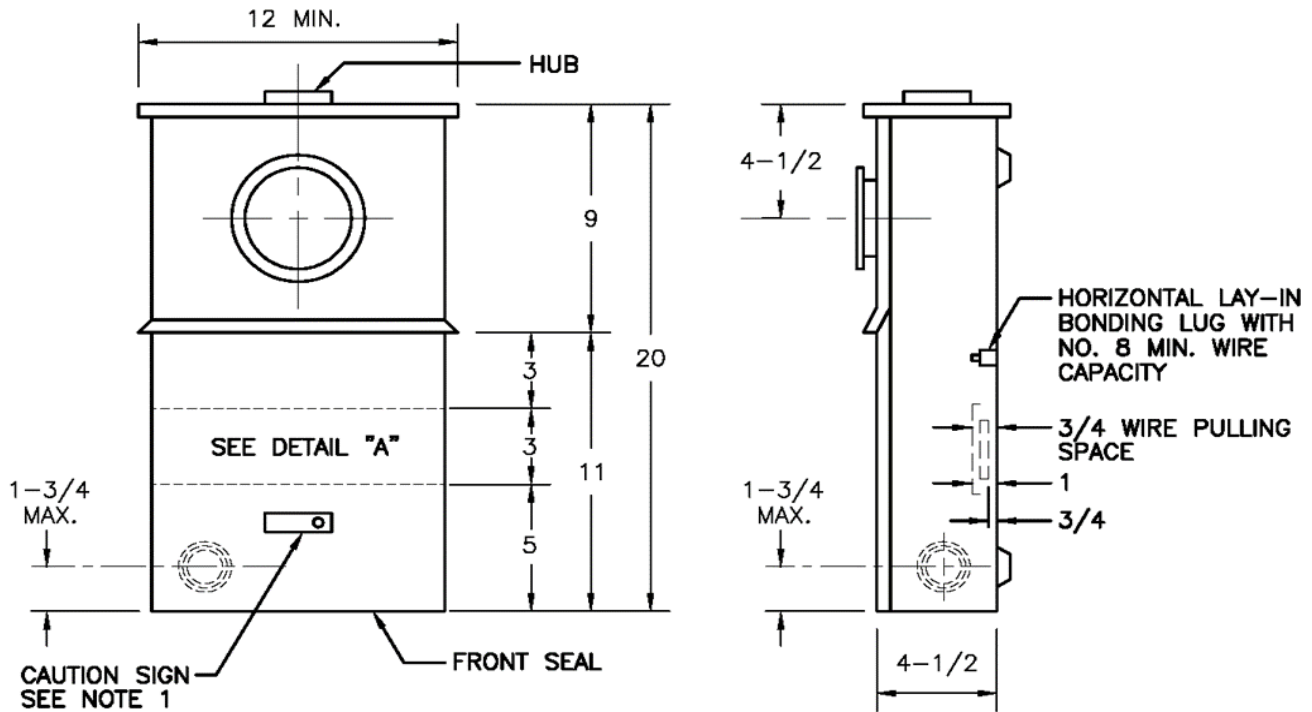

NOTES:

1. All section covers shall be independently removable. Upper cover shall be non-removable when meter is in place. Lower cover shall be sealable and permanently labeled: "DO NOT BREAK SEALS, NO FUSES INSIDE".
2. For meter socket configurations, see Section 200, Drawing F-4.

ALL DIMENSIONS SHOWN ARE IN INCHES

RE	CHANGE	BY	DSGN	APPV	DATE	REV	CHANGE	BY	DSGN	APPV	DATE
A						D					
B						E					
C						F					

Indicates Latest Revision

Completely Revised

New Page

Information Removed

SHEET
1 OF 1

EUSERC MANUAL

**SAFETY SOCKET FOR METERS USED
WITH INSTRUMENT - TRANSFORMERS**

SECTION
300
DRAWING
339

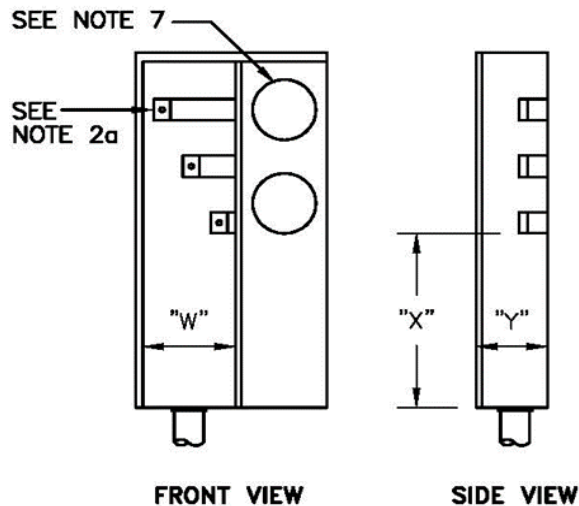

FIGURE 1

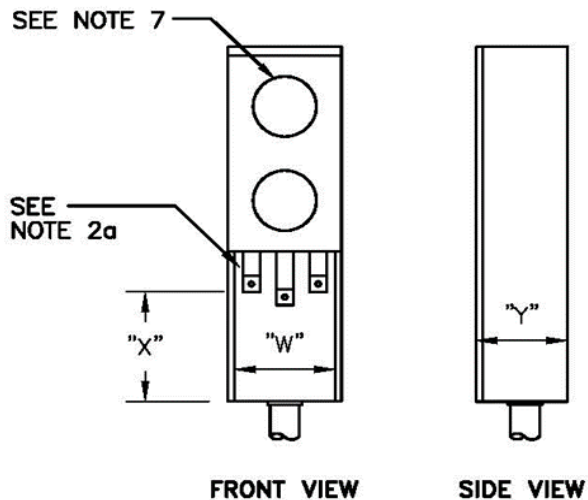

FIGURE 2

TYPICAL SERVICE TERMINATING ARRANGEMENTS. TWO (2) METERS (0-200 amp)

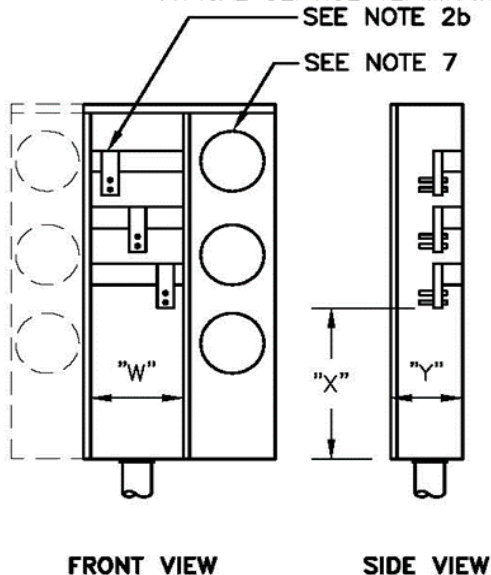

FIGURE 3

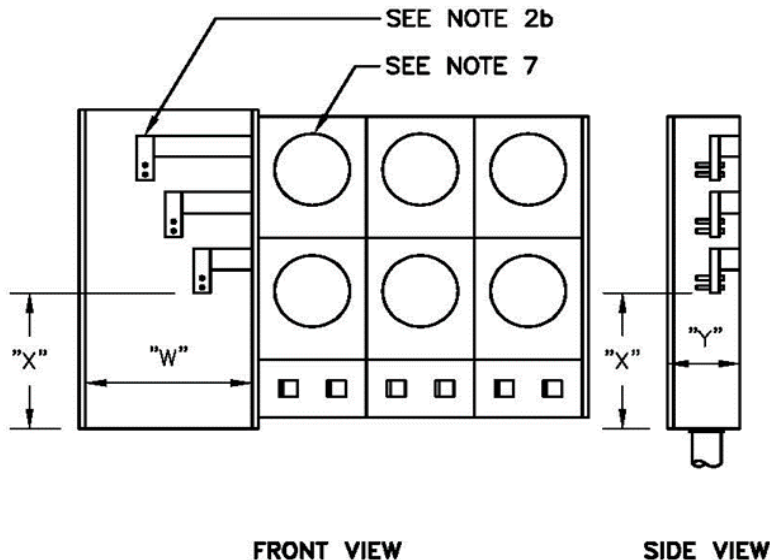

FIGURE 4

TYPICAL SERVICE TERMINATING ARRANGEMENTS. 3 - 6 METERS (201-600 AMPS)

EQUIPMENT RATING	"W"	"Y"	"X"
Amperes (Continuous)	SEE NOTE 6		SEE NOTES 3 & 4
0-200 AMPS	6-1/2 MIN.	5-1/2 MIN.	11 MIN.
201-600 AMPS	10-1/2 MIN.	6 MIN.	22 MIN.

ALL DIMENSIONS SHOWN ARE IN INCHES

RE	CHANGE	BY	DSGN	APPV	DATE	REV	CHANGE	BY	DSGN	APPV	DATE
A						D					
B						E					
C						F					

SHEET
1 OF 2

Indicates Latest Revision Completely Revised New Page Information Removed

EUSERC MANUAL

**COMBINATION TERMINATING ENCLOSURE AND MULTI-METER
PANELS FOR RESIDENTIAL SERVICES - 6 METER MAXIMUM
SINGLE PHASE 3 WIRE, 600 AMPERES MAXIMUM, 0-600 VOLTS**

SECTION
300
DRAWING
342

NOTES:

1. Pull section covers shall be:
 - a. Independent of other service equipment and removable without disturbing adjacent panels
 - b. Removable, sealable, provided with two lifting handles and limited to a maximum size of 9 square feet in area. See Drawing 300, General Notes for handle and sealing requirements.
2. Terminating facilities for service supply conductors shall be provided as follows:
 - a. For equipment rated 200 amperes (Figures 1 and 2), terminations may be aluminum-bodied, mechanical lugs with a range of No. 4 AWG through 250 KCMIL. See Drawing 301 for termination clearance and spacing requirements.
 - b. For equipment rated 201–600 amperes (Figures 3 and 4), terminations shall be two 1/2–inch steel bolts as shown. See Drawing 347 for additional bolt details and termination clearance and spacing requirements.
3. The neutral terminating position shall be identified. A bonding screw or jumper shall be provided if the neutral terminal is insulated from the enclosure.
4. For equipment rated up to 200 amperes, the neutral termination height may be reduced to 8–1/2 inches.
5. Cross–bussing of a different phase or potential installed behind or below any terminating position shall be fully insulated or barriered. Insulating barriers shall be rigid, non–flammable, rated for the serving voltage, resistant to ARC tracking, resistant to puncture or damage by impact and attached with non–conductive fasteners.
6. The minimum pull section access opening (W) is measured between the left side and right side return flanges.
7. See Drawing 353 for meter socket and panel requirements.

RE	CHANGE	BY	DSGN	APPV	DATE	REV	CHANGE	BY	DSGN	APPV	DATE
A						D					
B						E					
C						F					

SHEET 2 OF 2	Indicates Latest Revision	<input checked="" type="checkbox"/> Completely Revised	<input type="checkbox"/> New Page	<input type="checkbox"/> Information Removed
	EUSERC MANUAL			
	COMBINATION TERMINATING ENCLOSURE AND MULTI-METER PANELS FOR RESIDENTIAL SERVICES – 6 METER MAXIMUM SINGLE PHASE 3 WIRE, 600 AMPERES MAXIMUM, 0-600 VOLTS			
				SECTION 300 DRAWING 342

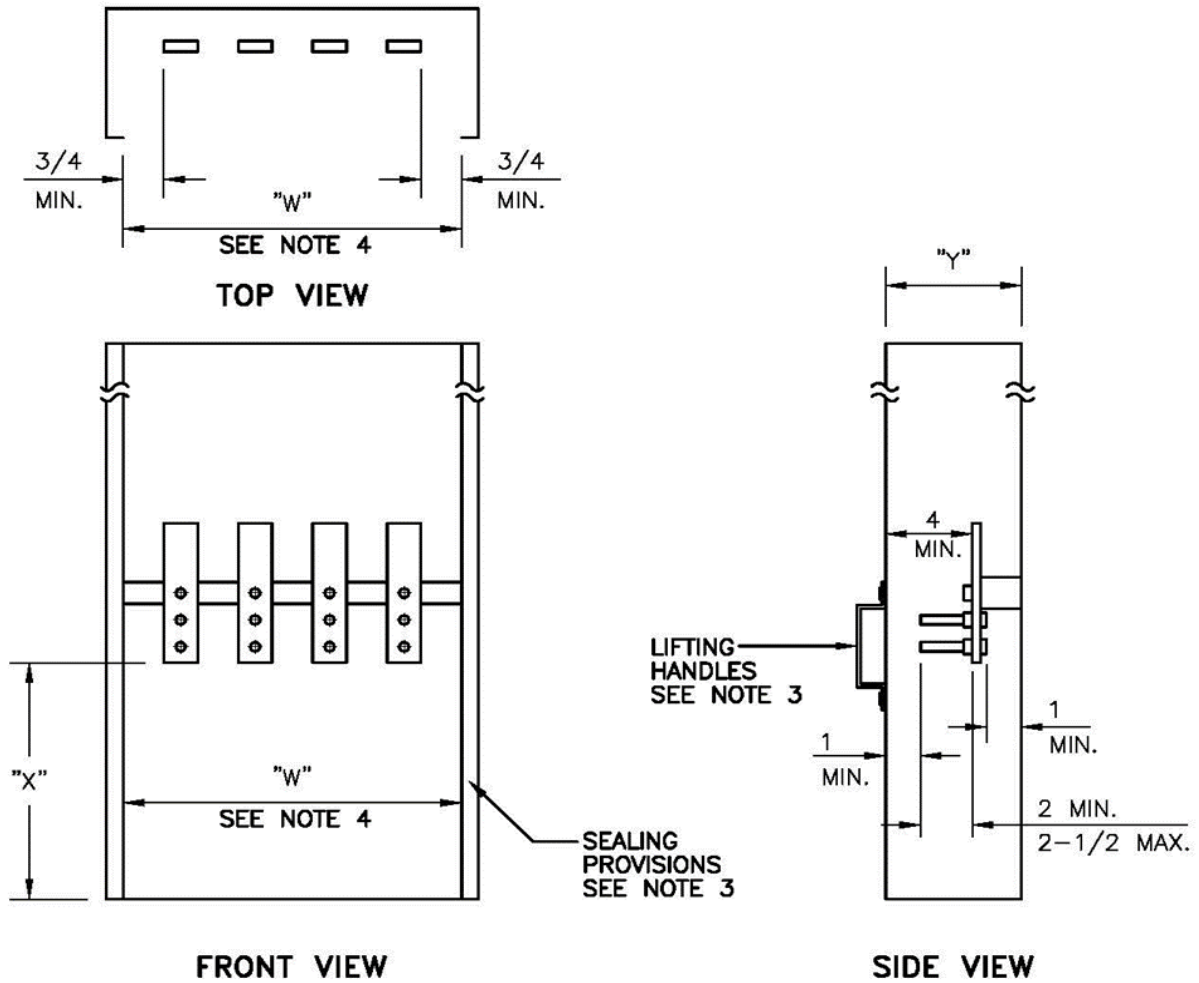

TABLE 1 (MINIMUM PULLBOX DIMENSIONS)

SERVICE AMPACITY	"W" (See note 4)		Y	X
	3-WIRE	4-WIRE		
0-200	10-1/2"	14"	6"	11"
201-400	10-1/2"	14"	6"	22"
401-800	16-1/2"	22"	11"	26"
801-1200	22-1/2"	30"	11"	26"

NOTES:

1. Terminating facilities for service supply conductors shall be two 1/2-inch steel bolts as shown. One set of bolts shall be provided for terminations rated up to 400 amperes, two sets of bolts for terminations rated 401-800 amperes and three sets of bolts for terminations rated 801-1200 amperes. See Drawing 347 for additional bolt details and termination and clearance requirements.

ALL DIMENSIONS SHOWN ARE IN INCHES

RE	CHANGE	BY	DSGN	APPV	DATE	REV	CHANGE	BY	DSGN	APPV	DATE
A						D					
B						E					
C						F					

SHEET 1 OF 2	<input type="checkbox"/> Indicates Latest Revision <input checked="" type="checkbox"/> Completely Revised <input type="checkbox"/> New Page <input type="checkbox"/> Information Removed	SECTION 300 DRAWING 343
	EUSERC MANUAL	
	WALL-MOUNTED PULL BOX WITH TERMINATING FACILITIES 0-600 VOLTS, 1200 AMPERES MAXIMUM	

2. Terminating facilities shall be secured to prevent turning or bus misalignment when the cables are installed.
3. Pull box covers shall be removable, sealable, provided with two lifting handles, and limited to a maximum size of 9 square feet in area. See Drawing 300, General Notes, for handle and sealing requirements.
4. The minimum pull box access opening (W) is measured between the left side and right side return flanges.

RE	CHANGE	BY	DSGN	APPV	DATE	REV	CHANGE	BY	DSGN	APPV	DATE
A						D					
B						E					
C						F					

SHEET 2 OF 2	Indicates Latest Revision	<input checked="" type="checkbox"/> Completely Revised	<input type="checkbox"/> New Page	<input type="checkbox"/> Information Removed	SECTION 300 DRAWING 343
	EUSERC MANUAL				
	WALL-MOUNTED PULL BOX WITH TERMINATING FACILITIES 0-600 VOLTS, 1200 AMPERES MAXIMUM				

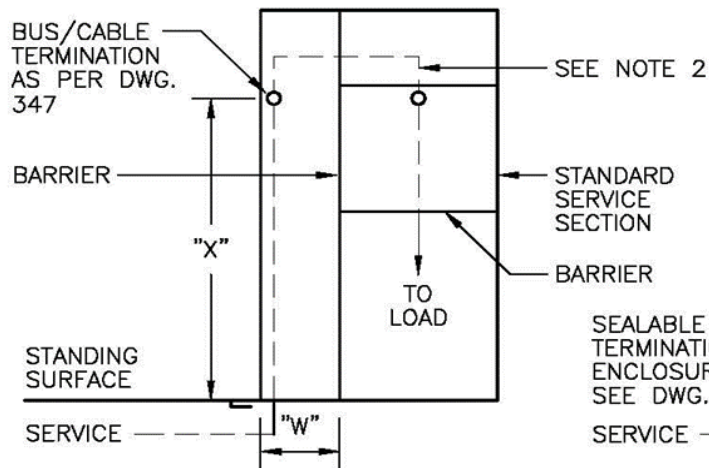

FIGURE 1
SWITCHBOARD
PULL SECTION

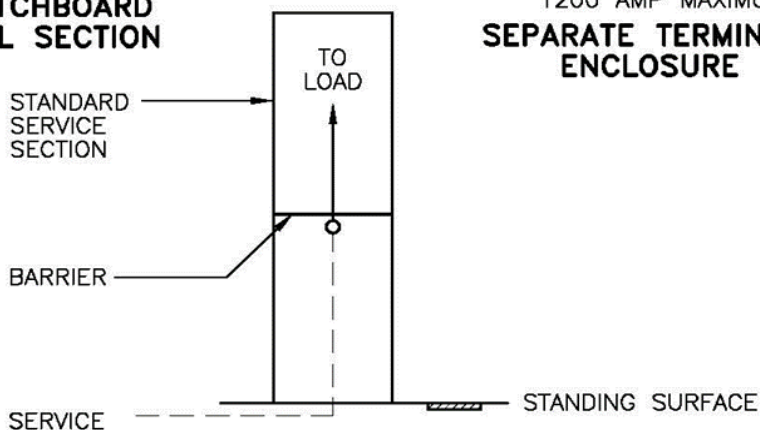

FIGURE 2
1200 AMP MAXIMUM
SEPARATE TERMINATION
ENCLOSURE

FIGURE 3
2000 AMP MAXIMUM
SEE DRAWING 327 FOR PULL SECTION REQUIREMENTS

BOTTOM FEED PULL SECTION

TABLE 1 MINIMUM PULLBOX DIMENSIONS – SEE NOTE 5

SWITCHBOARD RATING (AMPERES)	MINIMUM ACCESS OPENING DIMENSION (W)–SEE NOTE 4		TERMINATION HEIGHT (X)
	3-WIRE	4-WIRE	
BELOW 400	CONSULT SERVING AGENCY		
400 – 800	24	24	42 MIN. – 72 MAX.
801 – 1200	24	30	
1201 – 2000	30	35	
2001 – 3000	---	42	60 MIN. – 72 MAX.
3001 – 4000	---	44	60 MIN. – 72 MAX.

ALL DIMENSIONS SHOWN ARE IN INCHES

RE	CHANGE	BY	DSGN	APPV	DATE	REV	CHANGE	BY	DSGN	APPV	DATE
A						D					
B						E					
C						F					

Indicates Latest Revision Completely Revised New Page Information Removed

SHEET
1 OF 2

EUSERC MANUAL
**UNDERGROUND SERVICE TERMINATION STANDARD
SWITCHBOARD SERVICE CONNECTION 400 TO 4000 AMP,
0-600 VOLTS**

SECTION
300
DRAWING
345

NOTES:

1. A switchboard pull section as shown in Figure 1, a separate (nonattached) termination enclosure as shown in Figure 2, or a combination switchboard service section and pull section (bottom feed) as shown in Figure 3 shall be provided for underground services.
2. Bus bars or cables may extend from the pull section into switchboard service sections rated up to 800 amperes. Bus bars are required when the service section rating exceeds 800 amperes or multiple metering is supplied.
3. When the service section is supplied from a switchboard pull section as shown in Figure 1, the bus bars or cables shall enter through the side of the sealable section above the current-transformer compartment, or by means of horizontal cross-busing in back of the metering compartment.
4. When horizontal cross busing exists the switchboard pull section below the terminating facilities, the lowest cross bus unit and the transition bussing supplying the cross bus units shall not be less than two feet above the bottom of the enclosure or more than 8 inches from the back of the enclosure.
5. The minimum pull section access opening (W) is measured between the left side and right side return flanges.
6. Side or rear entry of service entrance cables into the pull section may require greater dimensions than shown in Table 1. Consult the serving agency for requirements.
7. All terminating enclosures (i.e. pull boxes and pull sections) shall have full front access. Cover panels shall be removable, sealable, provided with two lifting handles, and limited to a maximum of 9 square feet in area.
8. Sealing provisions shall consists of two drilled stud and wing-nut assemblies on opposite sides of the panels.
9. See Drawing 347 for construction details and clearance requirements for terminating facilities in pull boxes and pull section.
10. Ground bus, when provided, shall be located at the rear of the terminating enclosure.

RE	CHANGE	BY	DSGN	APPV	DATE	REV	CHANGE	BY	DSGN	APPV	DATE
A						D					
B						E					
C						F					

SHEET 2 OF 2	Indicates Latest Revision	<input checked="" type="checkbox"/> Completely Revised	<input type="checkbox"/> New Page	<input type="checkbox"/> Information Removed	SECTION 300 DRAWING 345
	EUSERC MANUAL				
	UNDERGROUND SERVICE TERMINATION STANDARD SWITCHBOARD SERVICE CONNECTION 400 TO 4000 AMP, 0-600 VOLTS				

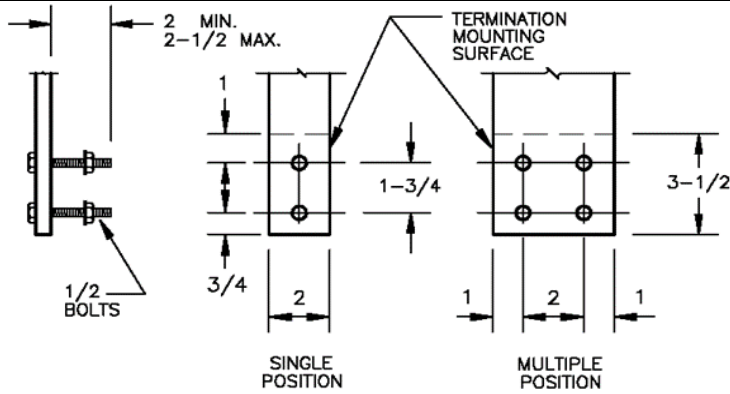

FIGURE 1

TERMINATING BOLT AND DRILLING DETAIL OF TERMINATING FACILITIES

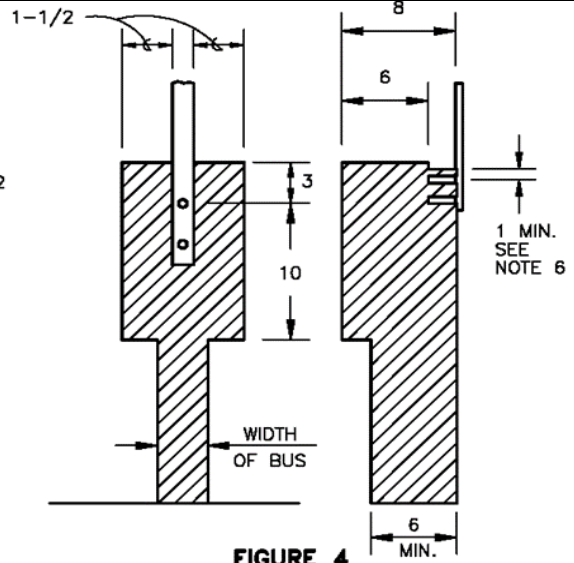

FIGURE 4

REQUIRED UNOBSTRUCTED WORKING SPACE FOR ALL TERMINATIONS.

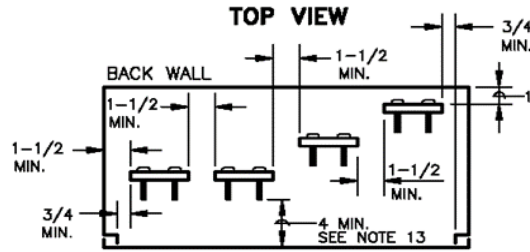

FIGURE 2

SPACING REQUIREMENTS FOR TERMINATING FACILITIES (SIDE BY OR STAGGERED)

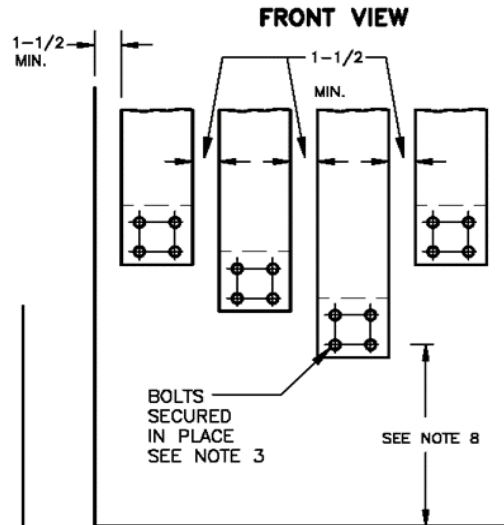

FIGURE 5

SPACING REQUIREMENTS FOR TOP TO BOTTOM STAGGER OF TERMINATING FACILITIES

NOTE:

4 INCH MIN. REQUIRED [ASSURE 1 INCH MINIMUM CLEARANCE FROM BODY OF TERMINATING LUG (WHEN IN PLACE TO FRONT PANEL)]

EXCEPTION: SEE NOTES 4 AND 5

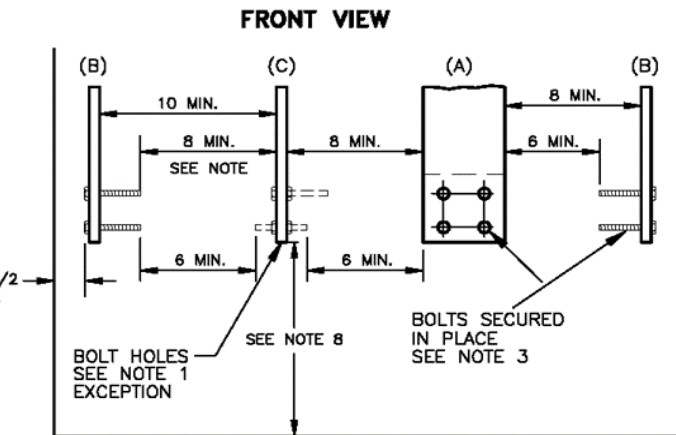

FIGURE 3

SPACING REQUIREMENTS FOR TERMINATING FACILITIES ACCESSIBLE FROM (A) FRONT ONLY, (B) ONE SIDE ONLY, OR (C) FROM EITHER SIDE. SEE NOTE 3 AND 4

ALL DIMENSIONS SHOWN ARE IN INCHES

RE	CHANGE	BY	DSGN	APPV	DATE	REV	CHANGE	BY	DSGN	APPV	DATE
A						D					
B						E					
C						F					

Indicates Latest Revision Completely Revised New Page Information Removed

SHEET
1 OF 3

EUSERC MANUAL
**UNDERGROUND SERVICE TERMINATING FACILITIES IN
PULL BOXES OR PULL SECTIONS, 0-600 VOLTS**

SECTION
300
DRAWING
347

NOTES:

1. One landing position is required for each 400 amperes of service ampacity or fraction thereof (i.e., one position for up to 400 amperes, two positions for 401 through 800 amperes, three positions for 801 through 1,200 amperes, etc.). Each landing position shall consist of two 1/2-inch steel bolts. The bolts shall extend from 2-inches to 2-1/2-inches from the mounting surface and be spaced on 1-3/4-inch vertical centers. When multiple landing positions per phase are required, the horizontal spacing between the bolt positions shall be 2-inches (minimum).

EXCEPTION: Edgewise terminating facilities may consist of 9/16-inch holes having the same spacing as specified for the 1/2-inch bolts as specified above and in Figure 1. The unobstructed working space shall be provided on both sides of the termination bus (see figure 3).

2. Each terminating bolt shall be provided with a spring washer and a nut. The spring washer may be either a cone-type (Belleville) washer or a split-ring washer and a flat washer. All parts shall be plated to prevent corrosion.

NOTE: When Belleville washers are used, the manufacturer shall provide a label with the required torque settings. This label shall be in a readily visible location within the compartment that the washers are being utilized.

3. Terminating bolts must be secured in place. "Secured in place" shall mean that the studs will not turn, back out, or loosen in any manner when tightening or loosening terminal nuts (including cross-threaded situations). Terminating bolts shall not be used to secure the termination bus in place.

4. In the terminal mounting area, which is defined as the area of the terminating facilities shown in Figure 1, a clear space (barrel of proximity) of 1-1/2 inches minimum is required around any terminating facility including its bolts and bolt heads, any other bus, any other terminating facility, or any grounded surface, except:
 - a. The minimum clearance to the back of the pull section may be reduced to 1 inch.
 - b. The minimum clearance to any fully insulated horizontal bus behind the terminating facility may be reduced to 1 inch.
 - c. The neutral terminating facility may have a minimum clearance of 1 inch from any grounded surface.

5. Each terminating facility shall have an unobstructed working space, accessible from the front of the pull section as viewed from the access compartment opening, in front of the entire mounting surface as shown in figure 4.

EXCEPTION: For terminating facilities with bolts facing the access opening as shown in figure 2, the required 1-1/2 inch side clearance (bus to access opening return flange) may be reduced to 3/4 inch.

6. The clearance directly above and measured from the center of the top termination bolt may be reduced to 1 inch to either an insulated surface or bus of the same potential.

7. No more than one termination facility may be mounted along any sidewall.

8. See Drawings 302, 303, 342, 343, and 345 for the minimum distance from the lowest bolt on the termination facility to the bottom of the termination enclosure.

RE	CHANGE	BY	DSGN	APPV	DATE	REV	CHANGE	BY	DSGN	APPV	DATE
A						D					
B						E					
C						F					

SHEET 2 OF 3	Indicates Latest Revision	<input checked="" type="checkbox"/> Completely Revised	<input type="checkbox"/> New Page	<input type="checkbox"/> Information Removed
	EUSERC MANUAL			
	UNDERGROUND SERVICE TERMINATING FACILITIES IN PULL BOXES OR PULL SECTIONS, 0-600 VOLTS			
				SECTION 300 DRAWING 347

9. Terminating facilities shall be secured to prevent turning or bus misalignment when the cables are installed.
10. The neutral terminating facility shall be permanently identified in clearly visible block lettering reading either "neutral" or "N".
11. For 120/240 volt 3Ø 4-wire delta services, the power leg (measuring 208-volts-to-ground) shall be identified with an orange color.
12. Cross-bussing of a different phase or potential installed behind or below any terminating position shall be fully insulated or barriered. Insulating barriers shall be rigid, non-flammable, rated for the serving voltage, resistant to ARC tracking, resistant to puncture or damage by impact and attached with non-conductive fasteners.
13. For switchboard pull sections, the minimum clearance from any energized part to a removable access cover panel shall be 4 inches. This clearance may be reduced to 1-1/2 inches when a safety barrier is provided by the manufacturer. The safety barrier shall:
 - a. Be constructed of a rigid insulating material, resistant to damage by impact or puncture, with a minimum thickness of 1/8 inch.
 - b. Extend a minimum of 10 inches below terminating bus and extend upward to cover all energized parts that infringe into the 4 inch minimum clearance dimension, and be removable.

 Note: Brackets and associated hardware used to mount the safety barrier shall not extend into the provided access opening.
 - c. Have a caution sign affixed to the barrier reading "WARNING: THE BARRIER MUST BE INSTALLED BEFORE REPLACING PULL SECTION COVERS". Additional caution signs shall be affixed to exterior of each section access cover reading "DO NOT REPLACE PULL SECTION COVERS UNTIL SAFETY BARRIER IS IN PLACE".
 - d. Screws or bolts requiring special tools for installation or removal are not acceptable.

RE	CHANGE	BY	DSGN	APPV	DATE	REV	CHANGE	BY	DSGN	APPV	DATE
A						D					
B						E					
C						F					

	<input type="checkbox"/> Indicates Latest Revision	<input checked="" type="checkbox"/> Completely Revised	<input type="checkbox"/> New Page	<input type="checkbox"/> Information Removed	
SHEET 3 OF 3	EUSERC MANUAL UNDERGROUND SERVICE TERMINATING FACILITIES IN PULL BOXES OR PULL SECTIONS, 0-600 VOLTS				SECTION 300 DRAWING 347

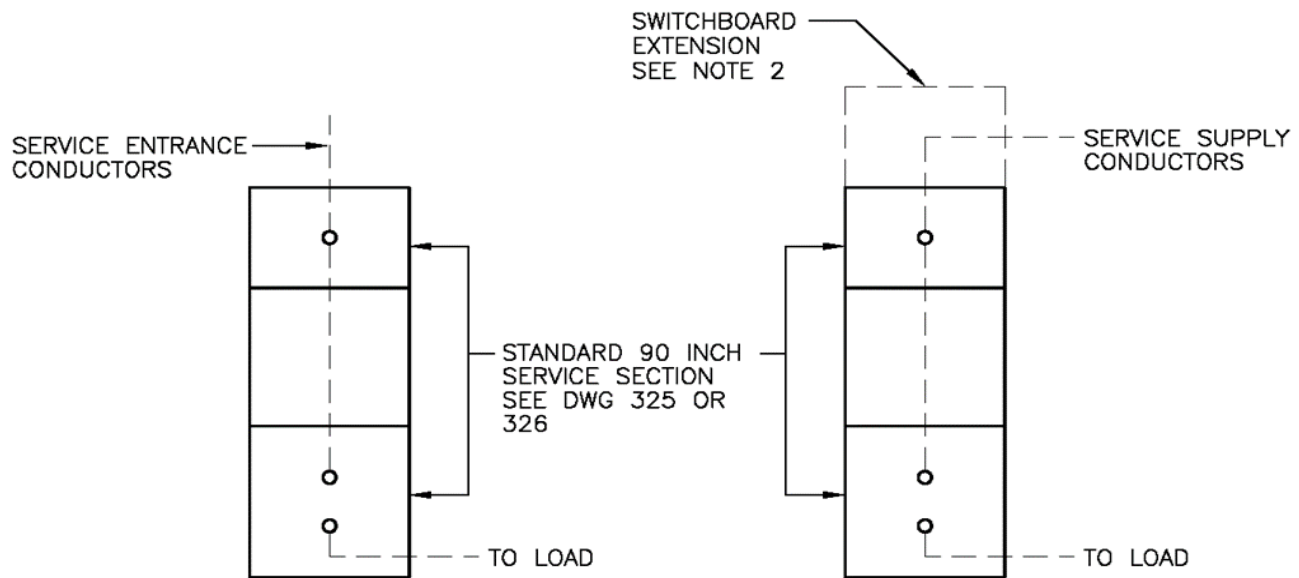

FIGURE 1

FIGURE 2

NOTES:

1. The service entrance conductors, Figure 1, either cable or bus bar, are furnished and installed by the customer in the following manner:
 - a. When switchboards are served through bus bar conductors, the conductors shall enter through the top, or at the side or back in the upper 10-inch section.
 - b. When switchboards are served through cable conductors, the conductors shall enter through the top of the board only, as shown Figure 1.
2. When the serving agency or customer requires incoming conduits from the side or rear for the service conductors, an extension as shown in Figure 2, or other special designed termination may be required. Consult the serving agency for the extension dimension.
3. The direction of feed is from top to bottom in the standard switchboard service section. Load conductors shall leave below the metering compartment and may not be routed back through the current transformer compartment in order to exit the service section.
4. Service entrance conductors shall be connected to the bussing in the service section with lugs approved by the serving agency for the type conductors used.

ALL DIMENSIONS SHOWN ARE IN INCHES

RE	CHANGE	BY	DSGN	APPV	DATE	REV	CHANGE	BY	DSGN	APPV	DATE
A						D					
B						E					
C						F					

Indicates Latest Revision
 Completely Revised
 New Page
 Information Removed

SHEET
1 OF 1

EUSERC MANUAL

**OVERHEAD SERVICE TERMINATION STANDARD
SWITCHBOARD SERVICE SECTION 0-600 VOLTS**

SECTION
300
DRAWING
348

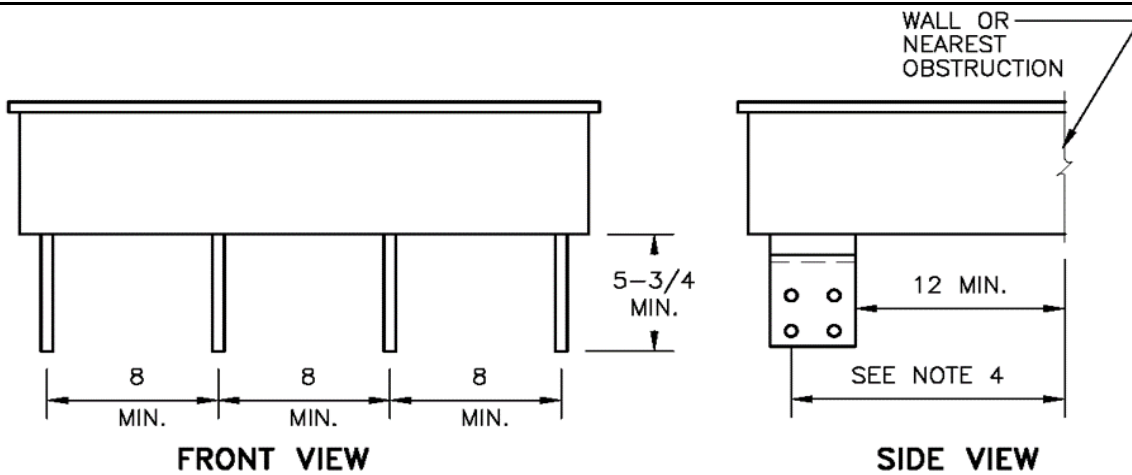

FRONT VIEW

SIDE VIEW

TERMINATING FACILITIES SAME LENGTH (4-WIRE SHOWN)

FIGURE 1

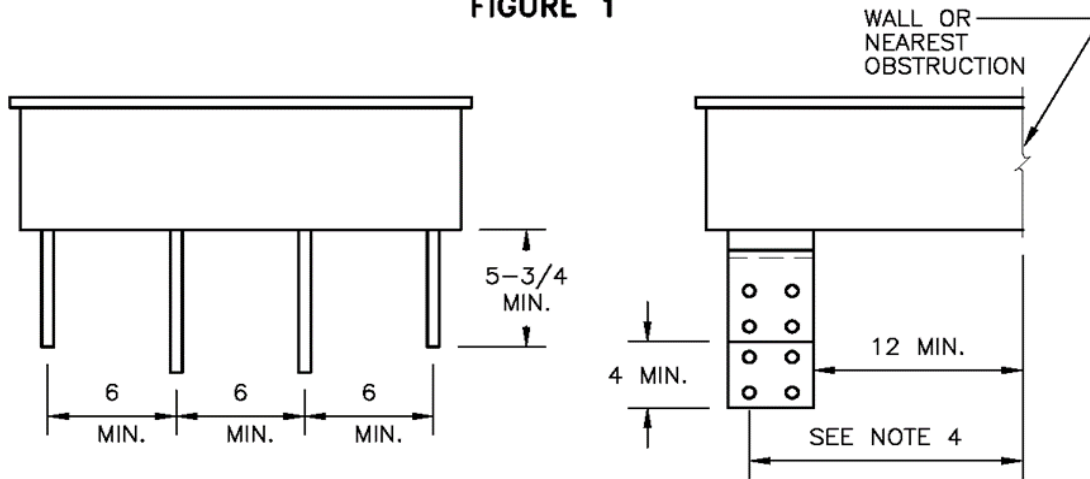

FRONT VIEW

SIDE VIEW

TERMINATING FACILITIES STAGGERED (4-WIRE SHOWN)

FIGURE 2

CLEARANCES INDICATED ARE FOR SINGLE LUG MOUNTING ONLY, NOT MULTIPLE STACKING LUGS

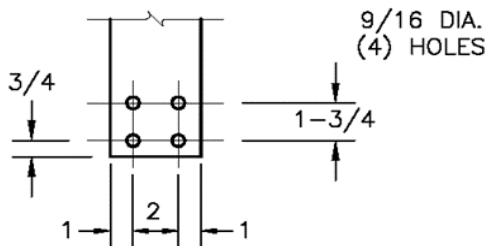

DRILLING DETAIL FOR TERMINALS (800 AMPERE TERMINAL SHOWN)
SEE NOTES 1, 2 AND 3

FIGURE 3

ALL DIMENSIONS SHOWN ARE IN INCHES

RE	CHANGE	BY	DSGN	APPV	DATE	REV	CHANGE	BY	DSGN	APPV	DATE
A						D					
B						E					
C						F					

Indicates Latest Revision

Completely Revised

New Page

Information Removed

SHEET
1 OF 2

EUSERC MANUAL

**OVERHEAD SERVICE TERMINATION STANDARD
SWITCHBOARD SERVICE SECTION 0-600 VOLTS**

**SECTION
300
DRAWING
349**

NOTES:

1. One terminal landing position is required for each 400 amperes of service ampacity (or portion thereof). Each landing position shall consist of two 9/16-inch holes spaced on 1-3/4 inch vertical centers. When multiple landing positions are required, the horizontal spacing between landing positions shall be 2 inches (minimum).
2. Neutral terminal shall be permanently marked by the manufacturer.
3. For 240/120 volts 3 ϕ 4-wire services, the power leg ("C" ϕ) terminal shall be permanently marked in orange color by the manufacturer.
4. The maximum dimension from the building or nearest obstruction to the outermost landing position shall not exceed 25 inches unless approved by the serving utility.
5. Service heads with enclosed terminating positions are not permitted.

RE	CHANGE	BY	DSGN	APPV	DATE	REV	CHANGE	BY	DSGN	APPV	DATE
A						D					
B						E					
C						F					

SHEET 2 OF 2	Indicates Latest Revision	<input checked="" type="checkbox"/> Completely Revised	<input type="checkbox"/> New Page	<input type="checkbox"/> Information Removed	SECTION 300 DRAWING 349
	EUSERC MANUAL				
	OVERHEAD SERVICE TERMINATION STANDARD SWITCHBOARD SERVICE SECTION 0-600 VOLTS				

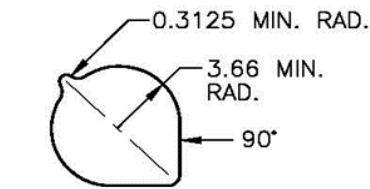

METER CUTOUT DETAIL

FIGURE 1

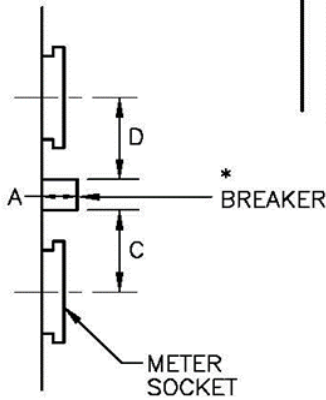

SIDE VIEW DETAIL

FIGURE 2

* Alternate breaker position below meter socket
See side view detail for clearance dimension

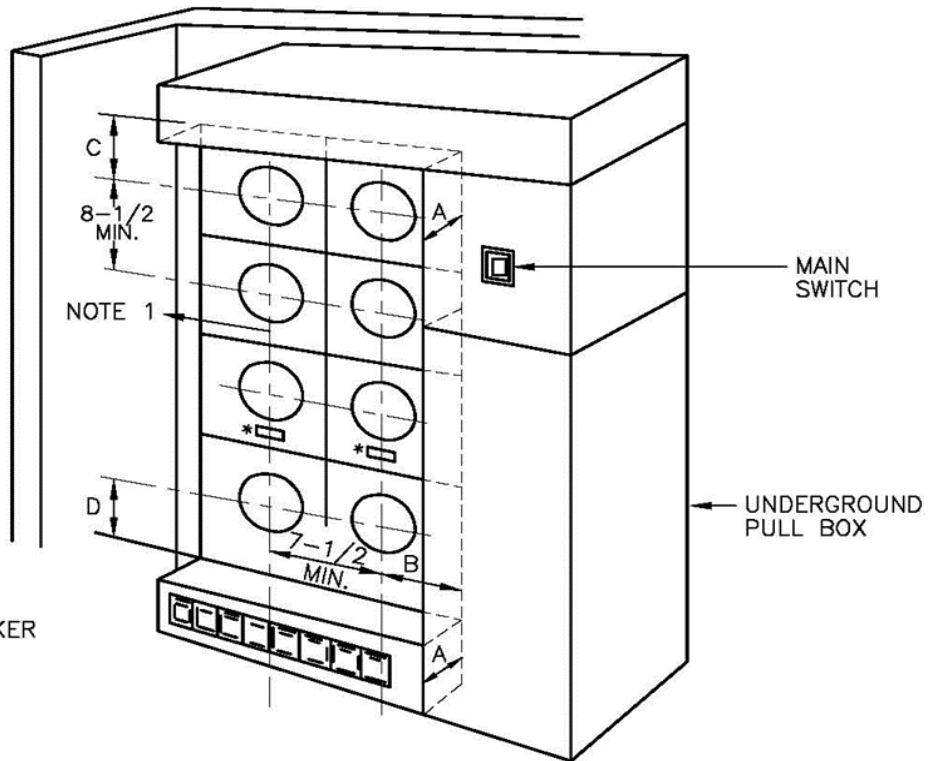

DIMENSIONS - INCHES			
"A" (PROTRUSIONS)	"B" MIN.	"C" MIN.	"D" MIN.
0 (No protrusion)	3-3/4"	4"	4-3/4"
Greater than 0" to 1-1/8"	4-1/4"	4"	4-3/4"
Greater than 1-1/8" to 2"	4-1/4"	4-1/4"	6-1/4"
Greater than 2" to 4"	6-1/4"	4-1/4"	8"
Greater than 4" to 11" max.	6-1/4"	10"	8"

ALL DIMENSIONS SHOWN ARE IN INCHES

RE	CHANGE	BY	DSGN	APPV	DATE	REV	CHANGE	BY	DSGN	APPV	DATE
A						D					
B						E					
C						F					

Indicates Latest Revision
 Completely Revised
 New Page
 Information Removed

SHEET
1 OF 2

EUSERC MANUAL
**CLEARANCES FOR RESIDENTIAL MULTIPLE
 METERING INSTALLATIONS**

**SECTION
 300
 DRAWING
 353**

NOTES:

1. Where an adjacent wall or other obstruction extends more than 11 inch perpendicular from the face of the meter panel, a 10 inch minimum dimension to the meter socket axis is required. For obstructions extending 11 inch or less from the meter panel, the side clearance shall conform to that of Dimension "B".
2. Panels shall be removable to provide access to the customers equipment with the utility meters and tamperproof sealing rings in place. When there is more than one meter socket per panel, the minimum meter cutout opening, as detailed in Figure 1 above shall apply.
3. Underground landing lugs shall not be placed under any socket cover.
4. Dimension "B" shall be increased by the amount that the main switch door, including operating handle, reduces the clearance when opened 90 degrees.
5. See drawing 300 II D Meter Heights for meter maximum and minimum heights.
6. Removable meter panel covers shall not exceed 6 square feet in area.
7. Distribution conductors shall be barriered from metering compartment.

RE	CHANGE	BY	DSGN	APPV	DATE	REV	CHANGE	BY	DSGN	APPV	DATE
A						D					
B						E					
C						F					

SHEET 2 OF 2	Indicates Latest Revision	<input checked="" type="checkbox"/> Completely Revised	<input type="checkbox"/> New Page	<input type="checkbox"/> Information Removed	SECTION 300 DRAWING 353
	EUSERC MANUAL				
	CLEARANCES FOR RESIDENTIAL MULTIPLE METERING INSTALLATIONS				

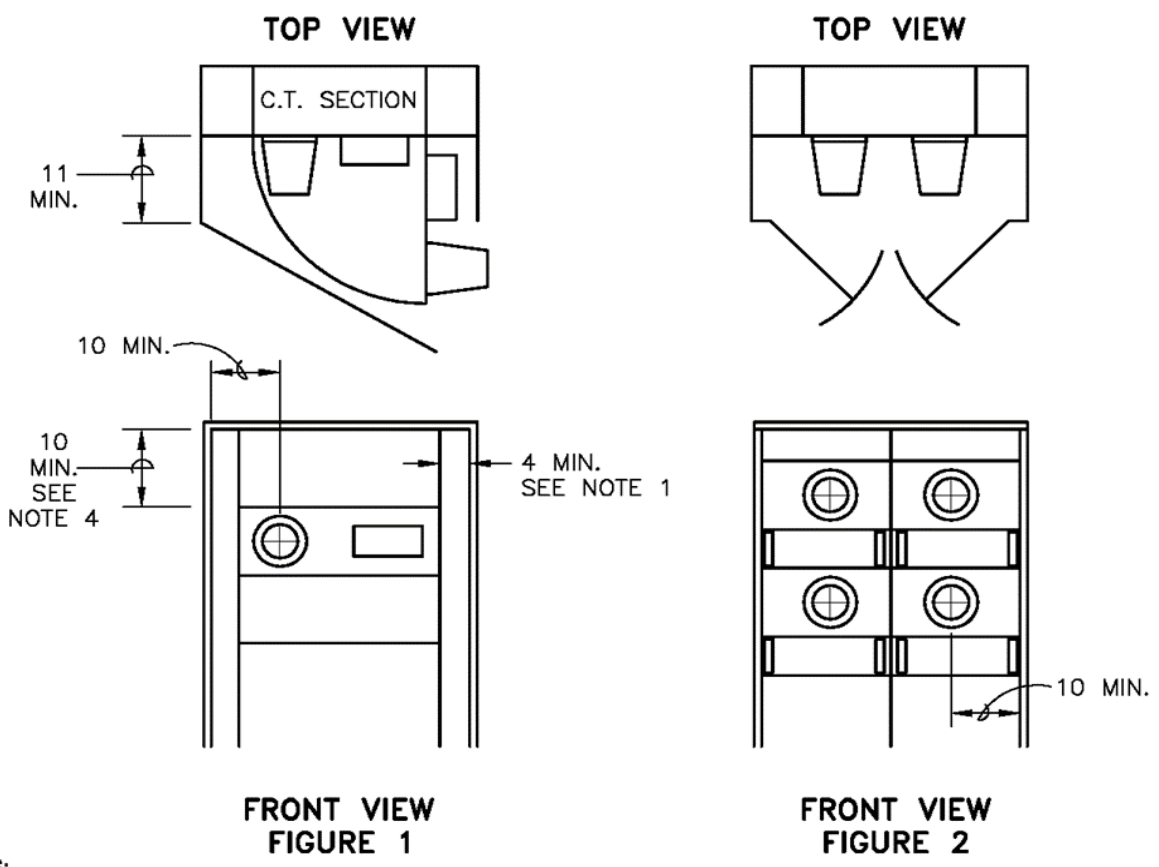

NOTES:

1. Hinged meter panel shall be capable of being opened 90–degrees with meter and test facilities in place, and provide the following clearances to any obstruction – 11 inches at the meter socket and 4 inches at the test–switch slotted opening. See Drawing 332 and 333 for hinged meter panels construction details.
2. Meter panels, either socket or blank, shall not be hinged to a hinged filler panel. Non–hinged filler panels shall not extend into the required instrument–transformer compartment access opening.
3. Enclosure doors providing access to utility compartments (i.e., metering sections and pull sections) shall be:
 - a. Equipped with a device to secure the doors in the open position at 90–degrees or more.
 - b. Secured in the closed position with a single, handle–operated, latching system. When provided with a locking means, each door, or set of doors, shall be equipped with an approved double–locking device, accepting padlocks with a 5/16 inch lock shaft, to allow access by both the serving utility and the customer.
4. Dimension may be reduced if the service section is supplied from horizontal cross–bussing or bus duct.

ALL DIMENSIONS SHOWN ARE IN INCHES

RE	CHANGE	BY	DSGN	APPV	DATE	REV	CHANGE	BY	DSGN	APPV	DATE
A						D					
B						E					
C						F					

SHEET 1 OF 1	Indicates Latest Revision	<input checked="" type="checkbox"/> Completely Revised	<input type="checkbox"/> New Page	<input type="checkbox"/> Information Removed
	EUSERC MANUAL			
	OUTDOOR OR RAIN TIGHT ENCLOSURES FOR SWITCHBOARDS, 0-600 VOLTS			
SECTION 300 DRAWING 354				

1103.1 **APS ADDENDUMS TO EUSERC DRAWINGS**

Although most EUSERC drawings are accepted by APS “as is”, some of the drawings are not. APS has provided an Addendum page for each drawing that it does not accepted “as is”.

This Addendum page will immediately follow the EUSERC page in this manual, and will explain any required changes and/or additions APS requires. **These changes are mandatory, and APS will not accept any equipment in violation of these addendums.**

METERING AND SERVICE EQUIPMENT (2400-27,000V)

I. SCOPE

This section of the requirements applies only to revenue metering compartments of indoor and outdoor metal-clad switchgear for 601 through 27,000-volt installations, (See Drawings 401 and 404 for enclosure requirements). Front access medium voltage switchgear is acceptable.

II. SWITCHGEAR WITH FUSED VOLTAGE TRANSFORMERS

A. General

1. Drawing Approval

The manufacturer shall submit copies of the design drawings to the serving agency as required for high-voltage metering equipment prior to fabrication. Such drawings shall indicate the customer's name, the job address, the contact address, and the telephone number of the manufacturer's representative.

2. Utility Compartment Labeling

Compartments of the metering enclosure shall be permanently labeled with machine engraved laminated phenolic (or equal) tags. Tags shall have quarter-inch white letters and numbers on red colored material that is readily visible and mechanically attached to the face of the following designated compartments.

- a. Utility voltage transformer compartment.
- b. Utility voltage transformer fuse compartment.
- c. Utility current transformer compartment.
- d. Utility service termination compartment.
- e. Utility metering panel.

3. Safety Grounding Provisions

Bare bus 7 inches above and below the current transformers shall be provided to permit application of serving agency safety grounds. A grounding knob may be provided on the line and load side of the bus at each current transformer location.

RE	CHANGE	BY	DSGN	APPV	DATE	REV	CHANGE	BY	DSGN	APPV	DATE
A						D					
B						E					
C						F					
SHEET 1 OF 6		Indicates Latest Revision	<input checked="" type="checkbox"/>	Completely Revised		New Page		Information Removed			
		EUSERC MANUAL									
		METERING & SERVICING EQUIPMENT HIGH VOLTAGE									
											SECTION 400

4. Meter Panel

Meter panel and hinges are to be designed to adequately support a 25-pound load applied at the unsupported end with 1/8-inch maximum sag when open. Bond meter door to switchgear enclosure with a #4 AWG flexible braided bond wire, (See drawing 408 and 409 for meter panel layout).

5. Lifting Handles

When lifting handles are required on panels and covers, each handle shall be sized for full hand grasping, securely attached, and have strength to withstand handling stresses of 75 pounds minimum (See Drawing 401, 408, 409 and 418).

Note: Chest type handles with a folding bale grasp are not acceptable.

6. B.I.L. Rating

B.I.L. (Basic Impulse Level) for the metering enclosure shall not be less than the customer's associated switchgear. Reference shall be made to ANSI Standards for the minimum acceptable.

B.I.L. ratings for high voltage switchboards built to the listed nominal voltages shown in the applicable tables "Voltages and Insulation Levels for AC Switch Gear Assemblies" and as tabulated for Metal Enclosed Interrupter Switchgear. The metering cubicle shall be labeled with the B.I.L. rating.

Rated Maximum Voltage (kV)	Impulse Withstand (BIL-kV)
4.76	60
8.25	75
15.0	95
27.0	125

7. Rear Door Access to Metering Cubicle

Working clearances (*) at the customer's job site may determine if the manufacturer is to furnish either a single or double full height hinged rear door access. Provisions for a three-point locking mechanism with hardware for attachment of the utility-furnished padlock are required.

All external doors shall, when open, be equipped with a device to hold the door at 90 degrees or more.

RE	CHANGE	BY	DSGN	APPV	DATE	REV	CHANGE	BY	DSGN	APPV	DATE
A						D					
B						E					
C						F					

SHEET 2 OF 6	Indicates Latest Revision	<input checked="" type="checkbox"/> Completely Revised	<input type="checkbox"/> New Page	<input type="checkbox"/> Information Removed
	EUSERC MANUAL			
	METERING & SERVICING EQUIPMENT HIGH VOLTAGE			
				SECTION 400

8. Weatherproofing and Locking

Enclosure sketches on the following drawings show equipment with weatherproof doors. The meter panel shall be hinged on the side opposite that of the outer door on weatherproof units to permit 90-degree openings with the meters and test facilities in place. The weatherproof doors may be omitted if the equipment is located indoors. If the outer door is omitted, the meter panel must be lockable. The front weatherproof door shall be a single door equipped with a latch-type handle to accommodate the serving agency's padlock.

9. CT and VT Installation

Current transformers, voltage transformers, meters, testing facilities, and all normal secondary wiring from the transformers to the meters will be furnished and installed by the serving agency.

10. Working Space for Medium Voltage Switchgear

(*) (Consult with utility for working clearance. Working clearances are governed by utility, code and customer requirements. Clearances can vary.)

B. Bus Bars and Conductors

1. Approved Bus Material

In CT & VT installations, copper buss shall be plated to prevent corrosion.

2. Bus Installation, Main Switch Ahead of Metering

When the main switch or circuit breaker enclosure is adjacent to and on the source side of the metering enclosure, connections from the load side of the main switch or circuit breaker to the line side of the current transformers shall be made using bus bars.

3. Conductors Passing Through Compartment Walls

When full BIL insulation cables or buses pass through compartment walls, full voltage and a BIL insulation system shall be provided.

RE	CHANGE	BY	DSGN	APPV	DATE	REV	CHANGE	BY	DSGN	APPV	DATE
A						D					
B						E					
C						F					

SHEET 3 OF 6	Indicates Latest Revision	<input checked="" type="checkbox"/> Completely Revised	<input type="checkbox"/> New Page	<input type="checkbox"/> Information Removed
	EUSERC MANUAL			
	METERING & SERVICING EQUIPMENT HIGH VOLTAGE			
SECTION 400				

C. Terminations

1. Service Cable Terminations

For service ampacities up to 800 amperes, one landing position (*) shall be provided on each phase and neutral bus for every 400 amperes, or portion thereof, of service ampacity. All bolts shall be secured in place and provided with nuts and pressure maintaining spring washers. All parts must be plated to prevent corrosion. Consult the serving agency for termination requirements when the ampacity exceeds 800 amperes.

Note: When Belleville (cone) washers are used, the manufacturer shall provide a label with the required torque setting. This label shall be in a readily visible location within the compartment that the washers are being utilized.

(*) Two 1/2-inch steel bolts on 1-3/4-inch vertical centers extending 1 inch minimum to 1-1/2 inches maximum from the mounting surface. Terminating bolts must be secured in place. "Secured in place" shall mean that the stud will not turn, back out, or loosen in any manner when tightening or loosening terminal nuts (including cross-threaded situations).

2. Insulated Neutral Termination

When an insulated neutral is required, it shall have full-voltage rated insulation from the metering cubicle. Consult the serving agency to determine if an insulated neutral is required.

D. Instrument Transformer Mounting Bases and Bus Links

Voltage transformer and current transformer mounting bases are to be provided by the manufacturer, (See Drawing 407).

1. Voltage Transformers

Locate the front or leading set of voltage transformer mounting holes 9 inches from the voltage transformer compartment door.

2. Current Transformers and Bus Link

The current transformer bus units shall be drilled and spaced to accept the current transformers of the proper rating and class, (See Drawing 407, 2 of 2) and permit installation and removal of individual transformers without disturbing adjacent transformers. Center bus shall include a removable link dimensioned the same as the current transformer bars on the metered phases.

RE	CHANGE	BY	DSGN	APPV	DATE	REV	CHANGE	BY	DSGN	APPV	DATE
A						D					
B						E					
C						F					

SHEET 4 OF 6	Indicates Latest Revision	<input checked="" type="checkbox"/>	Completely Revised	<input type="checkbox"/>	New Page	<input type="checkbox"/>	Information Removed	SECTION 400
	EUSERC MANUAL							
	METERING & SERVICING EQUIPMENT HIGH VOLTAGE							

3. Phase and Neutral Taps for Fuses and VT's

Lugs for voltage transformer phase and neutral connections shall be provided in the voltage transformer compartment.

4. Fuse Specification

Voltage transformer fuses shall be furnished and installed by the serving agency. The manufacturer shall provide mounting clips for indoor current limiting fuses with mounting clip separation and fuse ferrule diameter appropriate for the voltage rating of the equipment. Fuses shall be accessible through V.T. interlocked compartment door.

III. METERING COMPARTMENT

A. Voltage Transformer Disconnect Requirements

1. Key Interlocking is required between the voltage transformer disconnect and the voltage transformer compartment door so that, for personal safety, the voltage transformer compartment cannot be entered until all the following conditions are met:
 - a. The disconnect is fully open and visibly grounded.
 - b. When the voltage transformer disconnect is fully open, the disconnect blades must ground automatically.
 - c. The disconnect is locked open with a key interlock system.
2. The interlock system must prevent closing of the disconnect without first closing and locking the voltage transformer compartment.
3. The local utility will be provided with two keys for the interlock system.
4. Primary contacts for the voltage disconnect shall be of the blade and jaw design or equivalent to assure continued adequate contact. Wiping contact or pressure contact is not acceptable.
5. Operating handle or lever of the voltage transformer disconnect switch shall be pad lockable in the closed position.
6. The voltage transformer compartment door shall provide unobstructed access to the voltage transformer and fuses.

RE	CHANGE	BY	DSGN	APPV	DATE	REV	CHANGE	BY	DSGN	APPV	DATE
A						D					
B						E					
C						F					

SHEET 5 OF 6	Indicates Latest Revision	<input checked="" type="checkbox"/> Completely Revised	<input type="checkbox"/> New Page	<input type="checkbox"/> Information Removed
	EUSERC MANUAL			
	METERING & SERVICING EQUIPMENT HIGH VOLTAGE			
				SECTION 400

7. Voltage Transformer Disconnect shall have minimum voltage rating equal to the customer equipment supplied. Voltage rating and BIL shall be as listed in Table on II. A-6.

B. Alternate Meter Panel Location

1. As an alternate, the meter panel may be mounted in front of the CT/Termination compartment. When the meter panel is opened, the compartment should be fully isolated by a removable or hinged barrier.
2. All external and internal doors providing access to the CT bus including the outer door, meter panel door, and hinged barrier shall be equipped with a device to hold them open at 90 degrees or more.

IV. INSTRUMENT TRANSFORMER MOUNTING

See Drawing No. 407.

V. FUSE SPECIFICATION

Voltage transformer fuses shall be furnished and installed by the serving agency. The manufacturer shall provide mounting clips for indoor current limiting fuses with mounting clip separation and fuse ferrule diameter dimensions as shown on Drawings 401 and 404.

VI. METERING COMPARTMENT (27,000 VOLTS SERVICE)

- A. Vertical busing in the pull section and C.T. compartment shall be spaced 18 inches on the centerline between phases and the center phase shall be on the enclosure centerline.
- B. Current and voltage transformers will be outdoor type. Provide the transformer mounting bases and busing configuration (in the C.T. compartment) to accommodate this style of transformer. Consult utility for manufacturer catalog number and obtain the C.T. drawing.

RE	CHANGE	BY	DSGN	APPV	DATE	REV	CHANGE	BY	DSGN	APPV	DATE
A						D					
B						E					
C						F					

SHEET 6 OF 6	Indicates Latest Revision	<input checked="" type="checkbox"/> Completely Revised	<input type="checkbox"/> New Page	<input type="checkbox"/> Information Removed
	EUSERC MANUAL			
	METERING & SERVICING EQUIPMENT HIGH VOLTAGE			
SECTION 400				

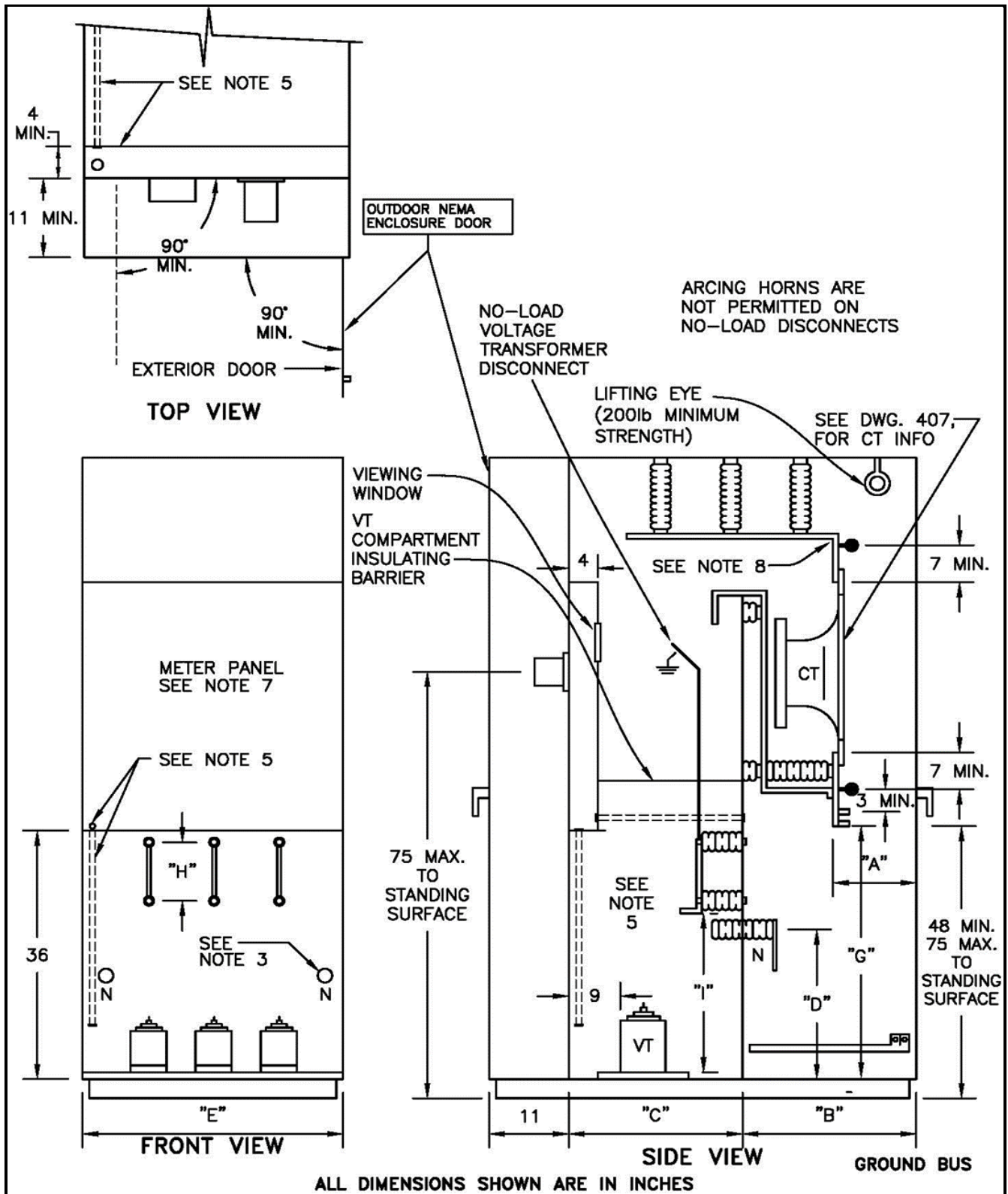

RE	CHANGE	BY	DSGN	APPV	DATE	REV	CHANGE	BY	DSGN	APPV	DATE
A						D					
B						E					
C						F					

SHEET 1 OF 3	Indicates Latest Revision	<input checked="" type="checkbox"/> Completely Revised	<input type="checkbox"/> New Page	<input type="checkbox"/> Information Removed
	EUSERC MANUAL			
	HIGH VOLTAGE METERING ENCLOSURE 2400 TO 15000 VOLT SERVICE			

**SECTION
400
DRAWING
401**

SPECIFICATIONS	VOLTAGE RATING	
	4800 Max.	4801-15000
MINIMUM BARE BUS CLEARANCE Ø TO GROUND	3-1/2"	6"
MINIMUM BARE BUS CLEARANCE Ø TO Ø	5"	7-1/2"
DIMENSION "A"	5" Min. 10" Max.	8" Min. 10" Max.
DIMENSION "B"	24" Min.	24" Min.
DIMENSION "C"	24" Min.	24" Min.
DIMENSION "D"	18" Min.	18" Min.
DIMENSION "E"	48" Min.	60" Min.
DIMENSION "G" (*See note below)	36-3/4" Min.	36-3/4" Min.
DIMENSION "H" FUSE MOUNTING (**) CLIP CENTER	8-1/2"	11-1/2"
DIMENSION "H" FUSE FERRULE DIAMETER	1-5/8"	1-5/8"
DIMENSION "I"	24"	24"

* Dimension "G" applies when used as a cable termination section.
Consult Utility.

** Fuse centerlines shall be adjustable to allow fuse voltage selection at not less than 70% of the actual system voltage application.

RE	CHANGE	BY	DSGN	APPV	DATE	REV	CHANGE	BY	DSGN	APPV	DATE
A						D					
B						E					
C						F					

<input type="checkbox"/>	Indicates Latest Revision	<input checked="" type="checkbox"/>	Completely Revised	<input type="checkbox"/>	New Page	<input type="checkbox"/>	Information Removed
--------------------------	---------------------------	-------------------------------------	--------------------	--------------------------	----------	--------------------------	---------------------

SHEET
2 OF 3

EUSERC MANUAL
**HIGH VOLTAGE METERING ENCLOSURE
2400 TO 15000 VOLT SERVICE**

SECTION
400
DRAWING
401

NOTES:

1. For rear access door refer to dwg 400, sheet 2 note 7.
2. Consult serving utility for neutral requirements in 4 wire applications.
3. Provide full voltage and bil insulated neutral bushing for connection to V.T. compartment.
4. Primary taps for V.T.'s shall be connected to line side of metering C.T.'s.
5. One inch, non-metallic, V.T. and C.T. conduit shall be located on the hinged side of the meter panel at a maximum of 75 inches above the standing surface. The conduits shall be continuous conduits with no junction boxes or condulets.
6. The grounding bus shall extend on either left or right side of the access area of the C.T. compartment. The grounding terminals for use with the ball studs shall be two aluminum-bodied mechanical lugs accepting a range of 6 AWG through 250 KCMIL conductors, and shall be identified with a label reading "SAFETY GROUNDING POINT FOR UTILITY USE ONLY".
7. For single socket meter panel requirements see drawing 408. For dual socket panel requirements see drawing 409.
8. Ball studs (1/2"-13 threads with insulating covers) for the attachment of safety grounds shall be provided on the line and load side of the current transformer (C.T.) bus units. The studs shall be located on less than 7 inches from the end of the bus unit and oriented toward the compartment access opening.

RE	CHANGE	BY	DSGN	APPV	DATE	REV	CHANGE	BY	DSGN	APPV	DATE
A						D					
B						E					
C						F					

SHEET 3 OF 3	Indicates Latest Revision	<input checked="" type="checkbox"/> Completely Revised	<input type="checkbox"/> New Page	<input type="checkbox"/> Information Removed	SECTION 400 DRAWING 401
	EUSERC MANUAL				
	HIGH VOLTAGE METERING ENCLOSURE 2400 TO 15000 VOLT SERVICE				

APS ADDENDUM TO EUSERC REQUIREMENTS

PAGE 401/APS

NOTES:

1. APS requires a horizontal insulating barrier between the PT compartment and the PT metering disconnect switch. The barrier shall be full width and depth and shall be supplied by the manufacturer.
2. APS is requiring a removable insulating barrier that shall be installed by the manufacturer. This is to shield personnel from any exposed buses in the CT compartment once the outer door is opened. The safety barrier shall be constructed of 1/4" thick clear acrylic, resistant to damage by impact or puncture, and shall be rated for the voltage served. This safety barrier shall be a two piece acrylic, extended a minimum of 10 inches below terminating bus, shall extend upward to cover all energized parts, and be hinged side as outer door. The safety barrier shall have a caution sign affixed to each barrier, reading "WARNING this barrier must be installed before closing compartment door."
3. APS requires additional labels stating the Service Voltage, Service Ampacity and the Site Address.
4. Modify drawing to show the insulated neutral bus extending from the service termination in the pull section through the metering PT compartment into the Customer's first disconnect compartment (non-sealed area), where it shall have a disconnect link if necessary and provisions for a bond tie on the line side of the said link. The insulated neutral bus is to be separate from the ground/bond bus (See Section 1000, Paragraph 705.6).
5. Grounding Stirrups shall be installed on each phase above service termination and below CT.
6. Labels need to be riveted on.
7. Underground Service Entrance Sections at primary voltage (greater than 600V) 3 phase are limited to 1,200 amps. Any customer requiring more than 1,200 amps will be required to install 2 or more service entrance sections.
8. Refer to ESRM 1000.4 for space requirements for primary metered switchgear (working space).



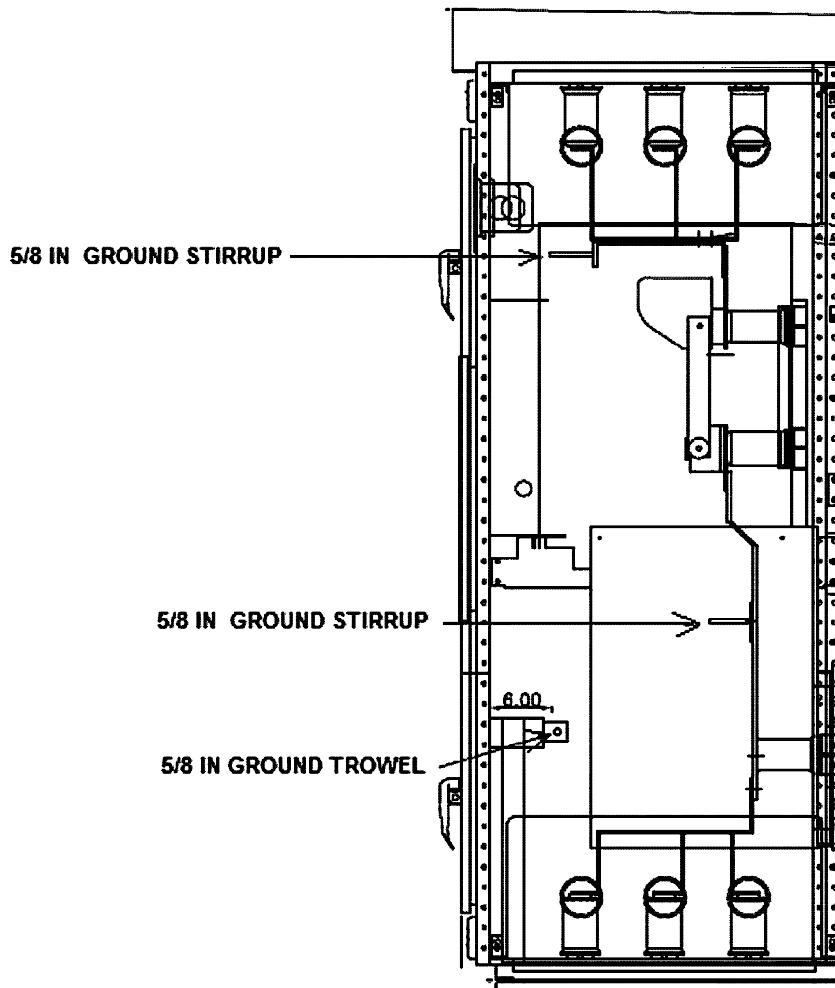
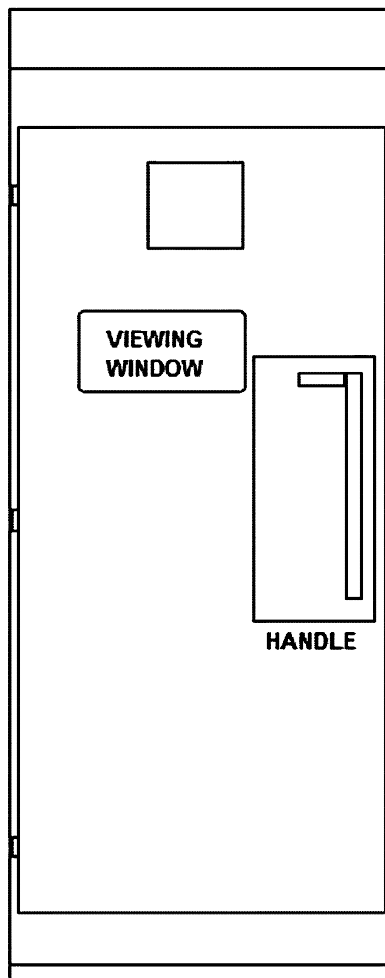

NOTES:

1. BUS ISOLATION SWITCH ENCLOSURE MUST BE BETWEEN EUSERC 401 METERING ENCLOSURE AND CUSTOMER'S FIRST MAIN DISCONNECT COMPARTMENT.
2. GROUNDING STIRRUPS ARE REQUIRED ON EACH SIDE OF SWITCH. GROUND ATTACHMENT POINTS MUST BE MINIMUM 5/8" ROUND BAR. GROUND STIRRUPS NEED TO BE MOUNTED HORIZONTALLY.
3. SWITCH TO BE GANG OPERATED.
4. GROUND BAR TO BE MINIMUM 5/8" ROUND BAR.
5. SWITCH HANDLE TO BE LOCKABLE IN BOTH OPEN AND CLOSED POSITIONS. MUST BE ABLE TO USE 5/16" SHACKLE PAD LOCK.
6. ENCLOSURE TO HAVE 120 VOLT LIGHT WITH SWITCH.
7. ENCLOSURE DOOR TO BE PAD LOCKABLE BUT NOT INTERLOCK OR KEYLOCK ON DOOR. MUST BE ABLE TO USE 5/16" SHACKLE PAD LOCK.
8. ISOLATED NEUTRAL BUS AND GROUND BUS FROM METERING ENCLOSURE MUST PASS THRU BUS ISOLATION SWITCH ENCLOSURE TO CUSTOMER'S FIRST MAIN DISCONNECT COMPARTMENT (NON SEALED AREA). SEE ADDENDUM 401/APS NOTE 5.
9. LABEL ENCLOSURE AS "BUS ISOLATION SWITCH". FOR LABEL REQUIREMENTS, SEE EUSERC DRAWING 400, SHEET 1, PARAGRAPH II A 2.

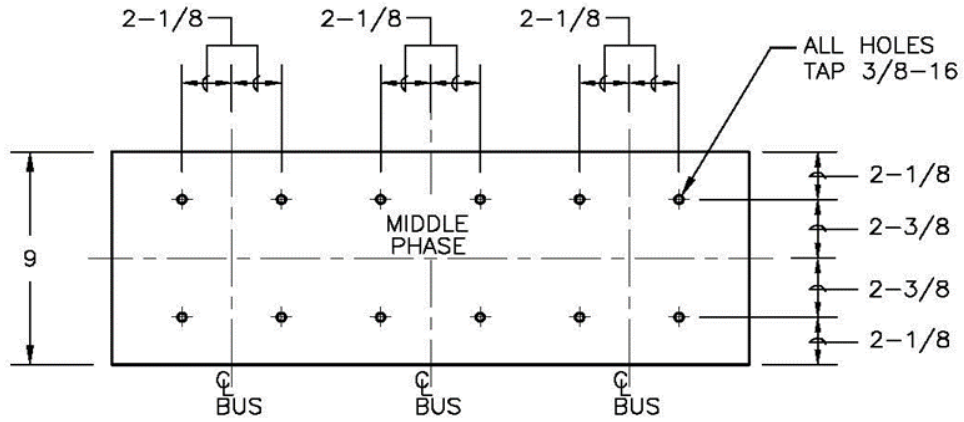

CURRENT TRANSFORMER MOUNTING BASE

NOTE: CENTER THE MOUNTING BASE BETWEEN THE UPPER AND LOWER CURRENT-TRANSFORMER BUS UNITS.

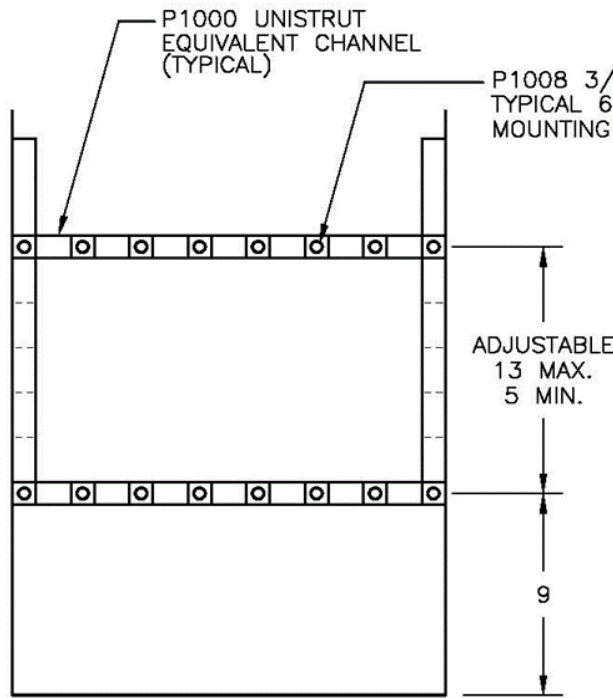

TOP VIEW OF COMPARTMENT VOLTAGE TRANSFORMER MOUNTING RAIL DETAIL

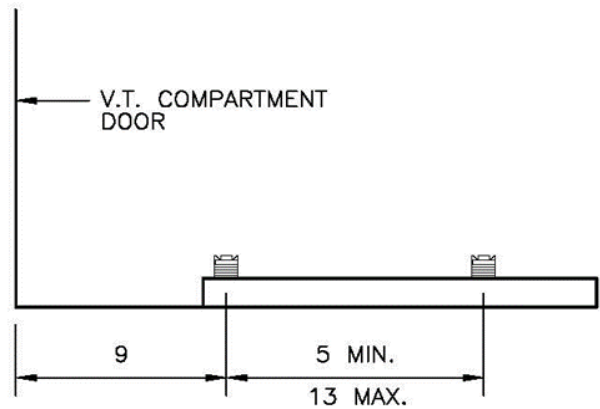

SIDE VIEW OF V.T. MOUNTING

ALL DIMENSIONS SHOWN ARE IN INCHES

RE	CHANGE	BY	DSGN	APPV	DATE	REV	CHANGE	BY	DSGN	APPV	DATE
A						D					
B						E					
C						F					

Indicates Latest Revision
 Completely Revised
 New Page
 Information Removed

SHEET
1 OF 2

EUSERC MANUAL
MOUNTING PATTERN FOR INSTRUMENT TRANSFORMERS
2400-27000 VOLT SERVICE
CONSULT UTILITY FOR 15001 VOLTS AND HIGHER

SECTION
400
DRAWING
407

PRIMARY RATING
800 AMPS OR LESS

PRIMARY RATING OVER
800 AMPS, 4 BOLT
MOUNTING AT EACH
C/T END

1/4 APPLIES TO MULTIPLE
BAR THICKNESS. SINGLE
BAR THICKNESS MAY BE
FROM 3/16 TO 3/8.

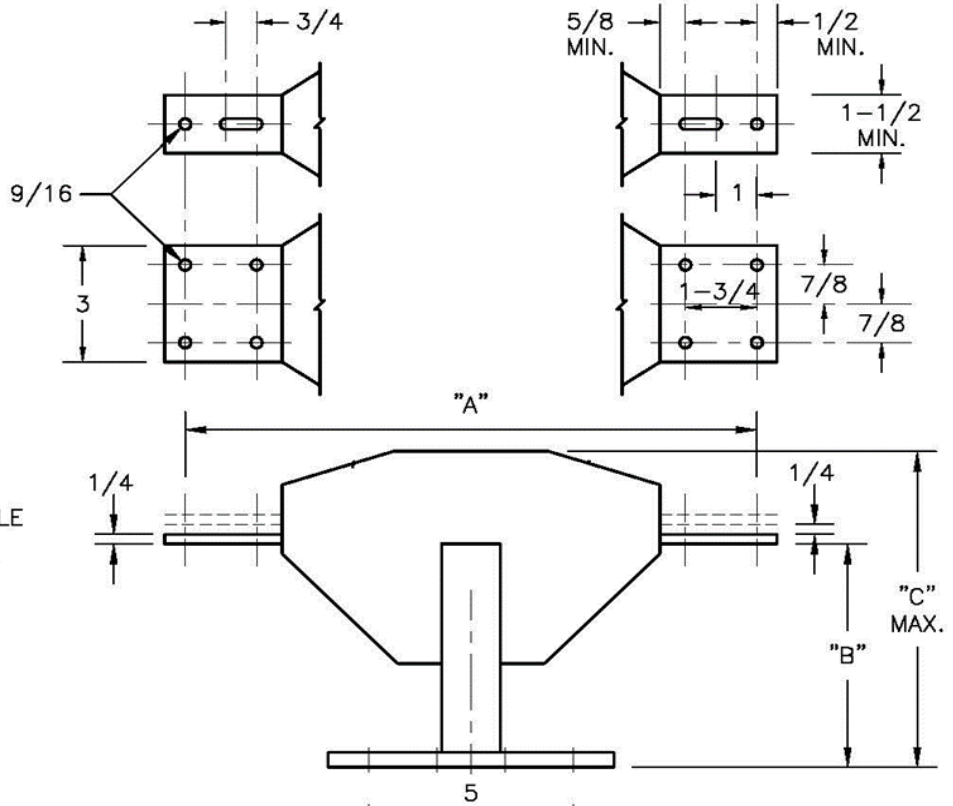

NOTES:
INSULATION CLASSES ARE 5,
8.7 AND 15 KV.

BASIC IMPULSE INSTALLATION
LEVELS (BIL) FOR THESE
CLASSES ARE 60, 75 AND
110 KV. RESPECTIVELY.

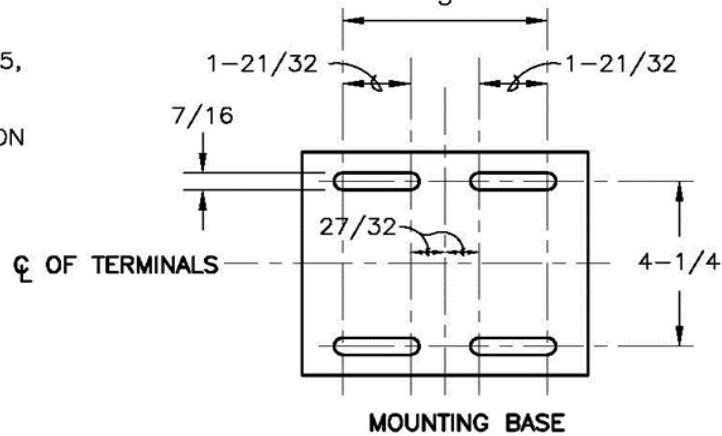

INSULATION CLASS KV.	DIMENSIONS IN INCHES *					
	"A"		"B"		"C" (Maximum)	
	AMPERES		AMPERES		AMPERES	
	10-800	1200-2000	10-800	1200-2000	10-800	1200-2000
5.0	14	-	5-3/4	-	8	-
8.7	15	-	8	-	10-1/2	-
15.0	22	26	9	5-3/4	11-1/4	13

* Unless otherwise indicated tolerance, plus or minus 1/16 inch.

ALL DIMENSIONS SHOWN ARE IN INCHES

RE	CHANGE	BY	DSGN	APPV	DATE	REV	CHANGE	BY	DSGN	APPV	DATE
A						D					
B						E					
C						F					

Indicates Latest Revision

Completely Revised

New Page

Information Removed

SHEET
2 OF 2

EUSERC MANUAL

INDOOR CURRENT TRANSFORMER DIMENSIONS
FOR METERING PURPOSES 5000-15000 VOLTS

SECTION
400
DRAWING
407

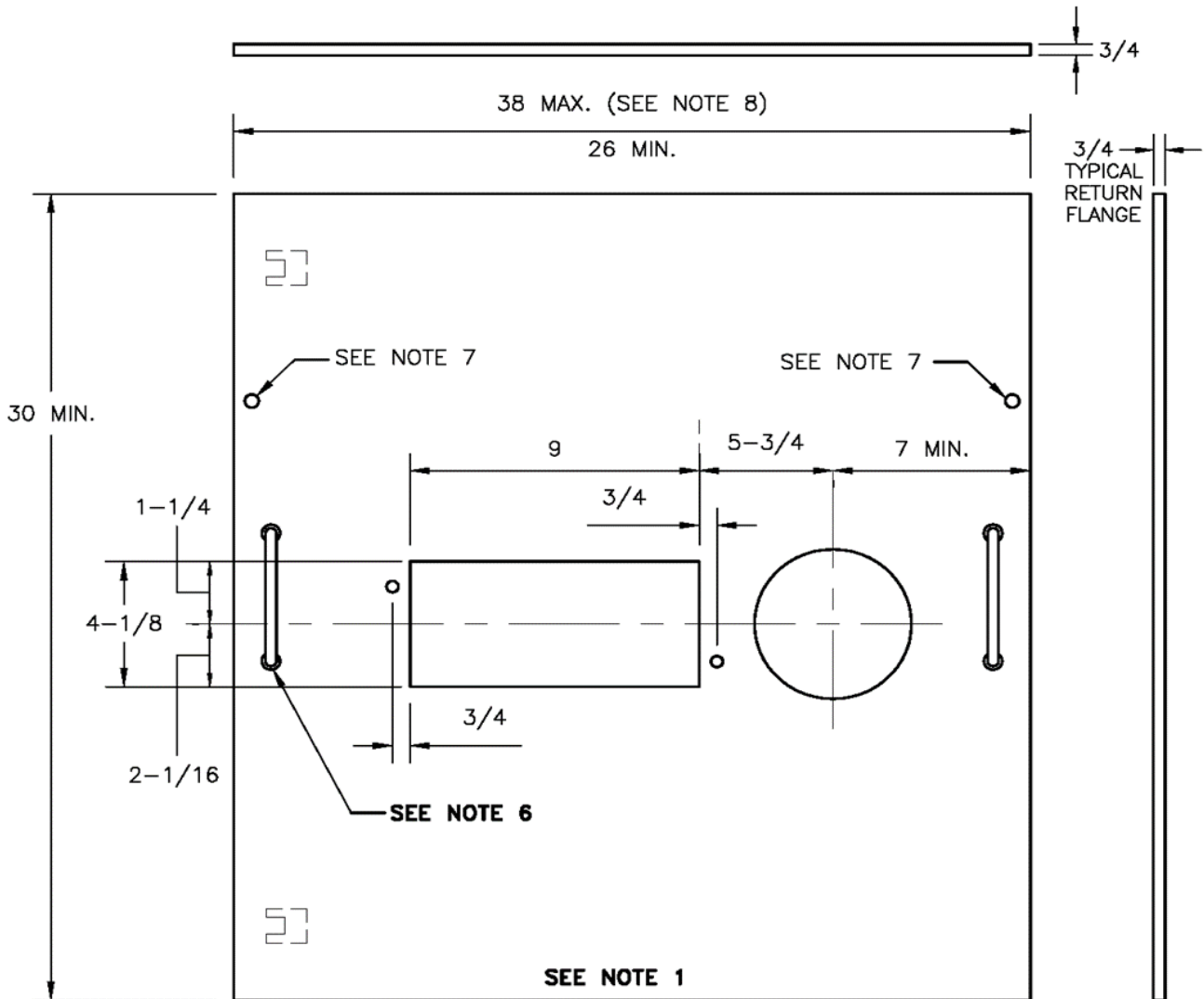

NOTE : TAP ALL HOLES 10-32 EXCEPT AS NOTED

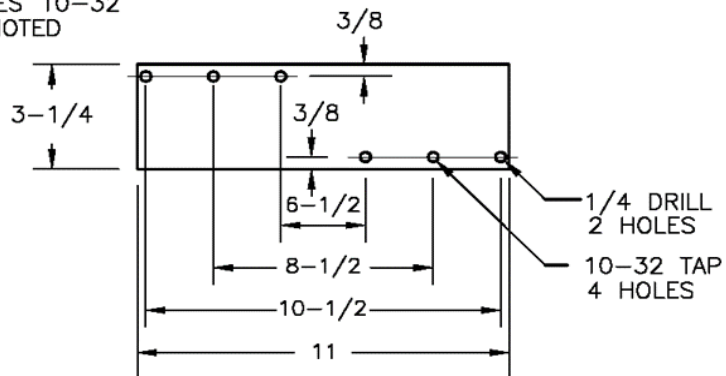

TEST SWITCH MOUNTING
ALL DIMENSIONS SHOWN ARE IN INCHES

RE	CHANGE	BY	DSGN	APPV	DATE	REV	CHANGE	BY	DSGN	APPV	DATE
A						D					
B						E					
C						F					

Indicates Latest Revision Completely Revised New Page Information Removed

SHEET
1 OF 2

EUSERC MANUAL
HINGED METER PANEL WITH SINGLE SOCKET
FOR 2400 TO 27000 VOLT SERVICE

SECTION
400
DRAWING
408

NOTES:

1. The panel shall be constructed of 12 gauge (min) steel and furnished with meter sockets, sealing rings, slotted openings, a removable plate for installation of a secondary test switch. Slotted openings and removable plate edges shall be smooth to prevent damage to meter wiring.

Note: When a cast meter mounting ring is provided, the screws used to attach to the meter panel shall provide a minimum 1/8-inch clearance between the screw heads and the back of the ring.

2. The removable plates shall be attached to the rear of the panel with screws that do not protrude through the face of the panel.
3. Meter sockets shall be designed for back connection.
4. The panel shall be reequipped with hinges. The hinges shall permit the panel to open to 90 degrees, and shall be easily interchangeable, right or left, on the meter socket panel. Removable pin type hinges shall be removable from the top.
5. The panel shall support a 25-pound load applied at the unsupported end when fully opened with a maximum sag of 1/8 inch.
6. The panel shall have a handle attached to both sides.
7. Stud and wing nuts shall be sealable when used.
8. Consult serving utility for panel width more than 38 inches.
9. Consult serving utility meter socket requirements.

RE	CHANGE	BY	DSGN	APPV	DATE	REV	CHANGE	BY	DSGN	APPV	DATE
A						D					
B						E					
C						F					

SHEET 2 OF 2	Indicates Latest Revision	<input checked="" type="checkbox"/> Completely Revised	<input type="checkbox"/> New Page	<input type="checkbox"/> Information Removed	SECTION 400 DRAWING 408
	EUSERC MANUAL				
	HINGED METER PANEL WITH SINGLE SOCKET FOR 2400 TO 27000 VOLT SERVICE				

SEE NOTE 11

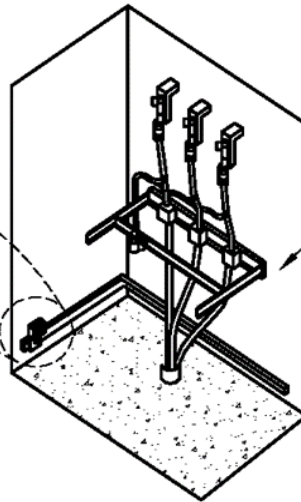
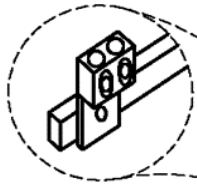

NOTE 8

MINIMUM BARE BUS CLEARANCE

4160 VOLTS (MAXIMUM): 5 PHASE TO PHASE, 3-1/2 PHASE TO GROUND
 4800-15,000 VOLTS: 7-1/2 PHASE TO PHASE, 6 PHASE TO GROUND
 SEE NOTE 7

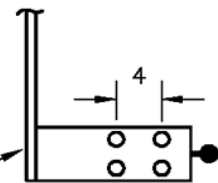

DETAIL
SIDE VIEW
TERMINATION
LUG PATTERN

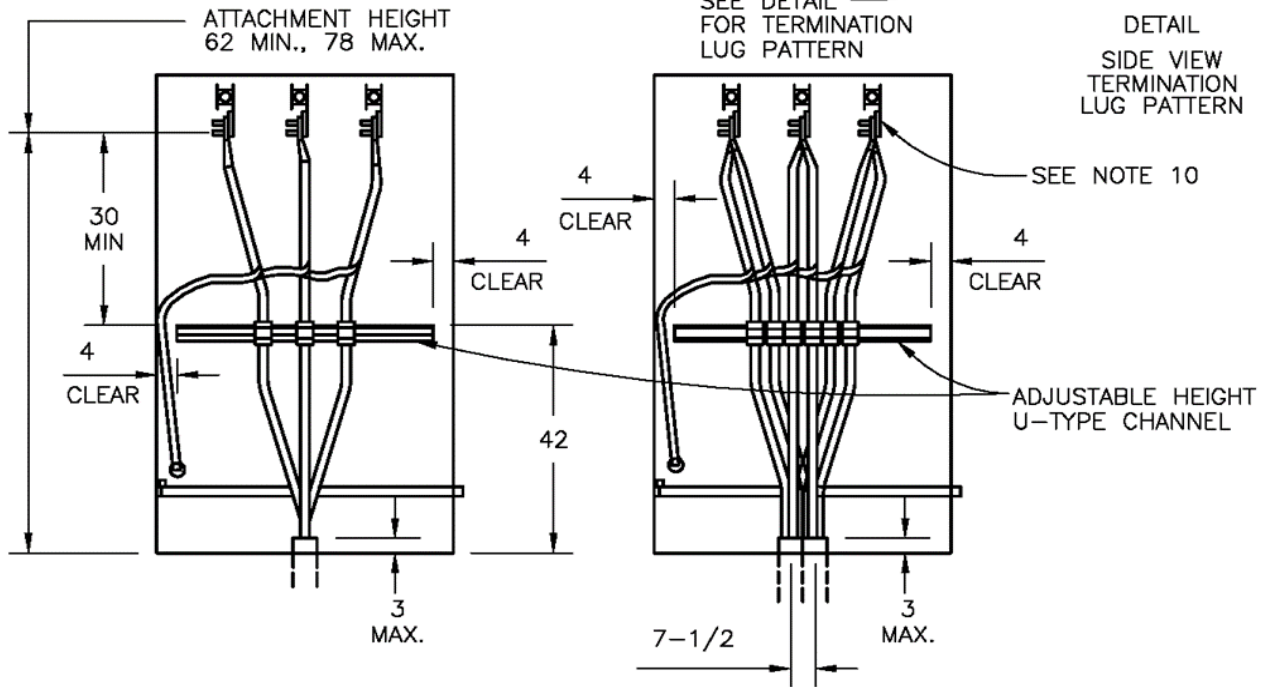

ALL DIMENSIONS SHOWN ARE IN INCHES

RE	CHANGE	BY	DSGN	APPV	DATE	REV	CHANGE	BY	DSGN	APPV	DATE
A						D					
B						E					
C						F					

Indicates Latest Revision Completely Revised New Page Information Removed

SHEET
1 OF 2

EUSERC MANUAL
UNDERGROUND SERVICE TERMINATING PULL SECTION
5000 TO 15000 VOLT SERVICE

SECTION
400
DRAWING
418

NOTES:

1. Consult the serving agency regarding the metering cubicle requirements.
2. Consult the serving agency for number of service cables, number, size, and location of service conduits, type of pull section and type of termination required.
3. To main or metering cubicle, consult the serving agency regarding metering sequence, (i.e. main-metering or metering-main.)
4. Consult the serving agency to determine if an insulated neutral landing is required.
5. Consult the serving agency for required clear working space in front of the enclosing panels.
6. Pull section cover panels shall be:
 - a. Independent of other service equipment and removable without disturbing adjacent panels.
 - b. Sealable, provided with lifting handles, be limited to 9 square feet in area with a maximum width or length of 5 feet.
Sealing provisions shall be studs and wing nuts.
 - c. A full height hinged door may be provided in place of removable cover panels. The door shall:
 - i. Be hinged and equipped with device to hold the door open at 90 degrees or more.
Clevis or removable pin type hinges shall be removable from the top.
 - ii. Be sealable and a handle on the side opposite the hinges.
7. Bare bus clearances shall be a minimum 12 inches from any phase bus to a removable access cover panel.
Note: For full height hinged doors see sheet 1 for bare bus clearances.
8. Furnish and install one piece of U-type channel as shown. One set of channel is required per set of conductors.
9. Bill for the pull section shall be not less than that for the customer's associated switchgear.
10. Ball studs (1/2"-13 threads with insulating covers) for the attachment of safety grounds shall be provided.
11. The ground bus shall extend to either the front left or right sides. The grounding terminals for use with the ball studs shall be two aluminum-bodied mechanical lugs accepting a range of 6 AWG through 250 KCMIL conductors and shall be identified with a label reading "SAFETY GROUNDING POINT FOR UTILITY USE ONLY."

RE	CHANGE	BY	DSGN	APPV	DATE	REV	CHANGE	BY	DSGN	APPV	DATE
A						D					
B						E					
C						F					

SHEET 2 OF 2	Indicates Latest Revision	<input checked="" type="checkbox"/> Completely Revised	<input type="checkbox"/> New Page	<input type="checkbox"/> Information Removed	SECTION 400 DRAWING 418
	EUSERC MANUAL				
	UNDERGROUND SERVICE TERMINATING PULL SECTION 5000 TO 15000 VOLT SERVICE				

**APS ADDENDUM TO EUSERC REQUIREMENTS
PAGE 407/APS**

NOTES:

1. APS requires the 2-bolt, 22 inch, on all 15KV insulation class CT designs from 0-1200 amps instead of the 0-800 amps indicated on the EUSERC Dwg 407.

