

**OVERHEAD SERVICE**  
**Table of Contents - Section 400**

<b>PARAGRAPH</b>		<b>PAGE</b>
<b>400.0</b>	<b>OVERHEAD SERVICES (0 - 600 VOLTS)</b> .....	<b>1</b>
400.1	GENERAL .....	1
400.2	IDENTIFICATION OF CONDUCTORS .....	1
400.3	MAXIMUM SERVICE ENTRANCE CONDUCTOR SIZE IN RISERS (OVERHEAD).....	2
<b>401.0</b>	<b>CLEARANCES ABOVE GROUND, THOROUGHFARES, DRIVEWAYS, ETC.</b> .....	<b>2</b>
401.0-1	CLEARANCES ABOVE GROUND (RESIDENTIAL) .....	3
401.0-2	CLEARANCES ABOVE GROUND – (INDUSTRIAL & NON-RESIDENTIAL).....	4
401.0-3	CLEARANCES ABOVE GROUND - SERVICES 0 TO 300 VOLTS & 301 VOLTS TO 750 VOLTS..	5
401.1	MINIMUM VERTICAL CLEARANCES (SWIM POOLS) .....	6
401.2	HORIZONTAL CLEARANCES FROM BUILDINGS .....	7
401.3	CLEARANCES OVER BUILDINGS AND STRUCTURES .....	7
401.3-1	CLEARANCES OVER BUILDINGS AND STRUCTURES .....	8
401.4	POINT OF ATTACHMENT STRUCTURE .....	9
401.4-1	ATTACHMENT STRUCTURE (BRACING RISERS) .....	9, 10
401.5	ALTERNATE METHOD FOR POINT OF ATTACHMENT (BLOCK STRUCTURE) .....	11
401.5-1	ALTERNATE METHOD FOR POINT OF ATTACHMENT (WOOD FRAME STRUCTURE) .....	12
401.6-1	UNIVERSAL SERVICE DROP CONDUIT BRACE.....	13
401.6-2	UNIVERSAL SERVICE DROP CONDUIT BRACE.....	14
401.7	CLEARANCE FROM DOORS, EXITS, WINDOWS, FIRE ESCAPES, BALCONIES, ETC. ....	15
401.8	CLEARANCE FROM CATV/TELCO AND ELECTRIC SERVICES .....	16
401.9	TYPICAL OVERHEAD RESIDENTIAL METER INSTALLATION .....	17
<b>402.0</b>	<b>CUSTOMER SERVICE POLE</b> .....	<b>18</b>
402.1	LOCATIONS: .....	18
402.2	REQUIREMENTS: (WOOD) .....	18
402.2-1	CUSTOMER SERVICE POLE 0 - 300 VOLTS .....	18
402.2-2	CUSTOMER SERVICE POLE .....	19
402.2-3	CUSTOMER SERVICE POLE REQUIREMENTS (WOOD) .....	20
402.3	CUSTOMER SERVICE POLE – SIZES .....	21
402.4	SERVICE RISER CONDUCTORS .....	22
402.5	TYPICAL POLE-MOUNTED METER INSTALLATION - RESIDENTIAL OR TEMPORARY.....	23
<b>403.0</b>	<b>OVERHEAD SERVICE WIRE SIZE TABLE</b> .....	<b>24</b>
<b>404.0</b>	<b>OVERHEAD 400 AMP C.T./METER CAN</b> .....	<b>25</b>



## 400.0 OVERHEAD SERVICES 0 - 600 VOLTS

---

### 400.1 GENERAL

1. APS RESERVES THE RIGHT TO DETERMINE ALL METER LOCATIONS, INCLUDING POINTS OF ATTACHMENT, AND ONLY AUTHORIZED APS PERSONNEL SHALL DETERMINE THIS LOCATION.
2. The height of the point of attachment on the Customer's building or structure for overhead services shall be adequate to provide vertical clearances between the service drop conductors and the ground as shown in Paragraph 401.0. **The service attachment height may have to be higher than the minimums shown in Paragraph 401.0 to maintain proper vertical clearance between service conductors and the ground.**
3. Weatherhead and open wires between the weatherhead and point of connection to the service drop (drip loop) shall have proper height above ground as shown in Paragraph 401.0.
4. The point of service drop attachment on a building shall be located on the exterior wall facing and nearest APS pole line. **The point of attachment shall be insulated.**
5. A solid point of attachment shall be provided to withstand a minimum 200 pounds of tension. The responsibility for furnishing a sufficiently substantial service support rests solely with the Customer (**Lag bolts are not considered acceptable**).
6. Where the service conduit riser is used as a mast for supporting the service drop, it shall be 1 1/2" min. size rigid steel conduit and contain no coupling or fittings which would be subject to strain by the service drop. If necessary to use more than one 10' length of conduit, the full length (10') conduit shall be the upper conduit, thereby putting the coupling below any strain.
7. **EMT or Plastic shall not be used for riser.**
8. **Point of attachment on service conduit risers to be no more than 20" above the roof or parapet wall support for 1-1/2" rigid steel conduit, no more than 30" above the roof or parapet wall support for 2" rigid steel conduit and no more than 50" above the roof or parapet wall support for 2-1/2" and larger rigid steel conduit. Risers that exceed these height limits require back bracing. The point of attachment shall not be higher than 6' above the roof or the parapet wall support. See Paragraphs 401.4, 401.4-1, and Figures 1, 2, 3 and 4. See Paragraph 401.5 for alternative method for point of attachment.**
9. In the event a mast type riser is required to attain the required height, it shall be of such construction and so supported that it will withstand the strain imposed by the service drop. Mast type risers shall be braced every 30" and within 6" of the top of the wall. Raceway fittings shall be of a type identified for use with service masts.
10. Service riser conduits shall be so located that the corner of the point of attachment for the service drop will be within twelve (12) inches of the center of the weatherhead.
11. Single risers require 24" conductor leads for connection by company. When multiple risers are used, 36" leads are required.
12. A maximum of three (3) service riser conduits may be supplied from one overhead service drop. Multiple risers shall be placed a maximum of 12" apart and be braced together within 6" to 12" of the weatherhead per Paragraph 401.6-1, Detail A.
13. No foreign attachments shall be permitted on a service riser conduit.
14. **Overhead raceway (riser) shall not be enclosed by any wall.**

**NOTE** - Attachment tensions greater than 200 pounds may be required in special cases such as for bus duct risers.

---

### 400.2 IDENTIFICATION OF CONDUCTORS

Any neutral or delta power (high) leg of service entrance conductors, provided as required for various classes of service, shall be permanently identified. The identification shall be applied on the open conductors (drip loop) extended from the weatherhead or on the bus-stubs of a bus-duct servicehead, whichever is applicable. The neutral shall be white and the delta power (high) leg shall be orange. (See Section 300, Paragraphs 303.7 and 304.3).



**400.3 MAXIMUM SERVICE ENTRANCE CONDUCTOR SIZE IN RISERS (OVERHEAD)**

Service entrance conductors installed by the customer shall be sized per NEC requirements. Maximum size conductor shall be 750 MCM with a maximum number of two conductors per phase.

If service riser conductors are to be paralleled, they shall be paralleled in separate conduits. When metallic (ferrous) conduit is used or there is any encirclement of ferrous metal, induced current heating will damage the cable insulation. The only acceptable method is to install one of each phase conductor and neutral in each metallic conduit (e.g. ABCN of a four wire service).

**EXCEPTION:**

Parallel service may be installed in one riser provided the conduit is sized properly per NEC for the total amount of wire installed. Parallel conductors must terminate on a common bus (e.g. 8 conductors in one conduit for a four wire service, 2 - ABCN).

**401.0 CLEARANCES ABOVE GROUND, THOROUGHFARES, DRIVEWAYS, ETC.**

Service drop conductors when not in excess of 300 volts phase to ground, shall have the following minimum clearance at the lowest point of the span. (The height of the point of attachment shall be governed by these clearances.) Clearances are based on conductors supported on and cabled together with an effectively grounded messenger.

Crossing over areas accessible to pedestrians only.....	12.0 ft
Crossing over residential driveways NOTES 1 & 2.....	12.5 ft
Crossing over non-residential areas, parking lots, agricultural or other areas subject to truck traffic NOTE 2.....	18.0 ft
Crossing over non-residential or industrial parking lots, not subject to truck traffic NOTES 2 & 3.....	12.5 ft
Crossing over public streets, alleys or roads in urban or rural districts and driveways on other than residential property.....	18.0 ft
Crossing over railroad tracks.....	27.0 ft

**NOTES:**

1. Residential driveways subject to RV or commercial truck traffic require 18' of clearance.
2. Trucks are defined as any vehicle exceeding 8 feet in height.
3. Truck height must be physically restricted.
4. Minimum height for Drip Loop shall be 10.5 feet.

**SPECIAL NOTE:**

The minimum Point of Attachment (POA) height shall be 12.5'. The POA height may need to be higher than the minimum to maintain proper clearances. Additional height may be required according to the Authority Having Jurisdiction (AHJ).

Where clearance is questionable, please call APS for instructions before installing service entrance, conduit and other equipment.

It is recommended that an onsite meeting be requested with an APS Representative to determine service attachment height before installation of service entrance, conduit and other equipment.



**401.0-1 CLEARANCE ABOVE GROUND - RESIDENTIAL**

THESE MINIMUM CLEARANCES APPLY TO THE LOWEST POINT OF SERVICE DROP SAG

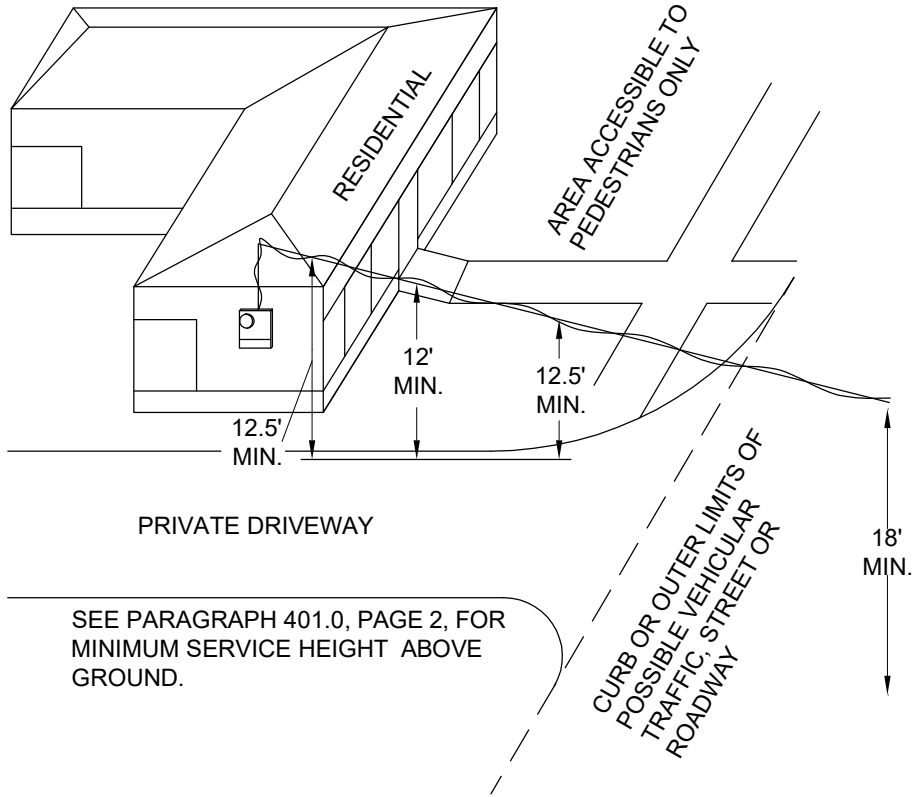
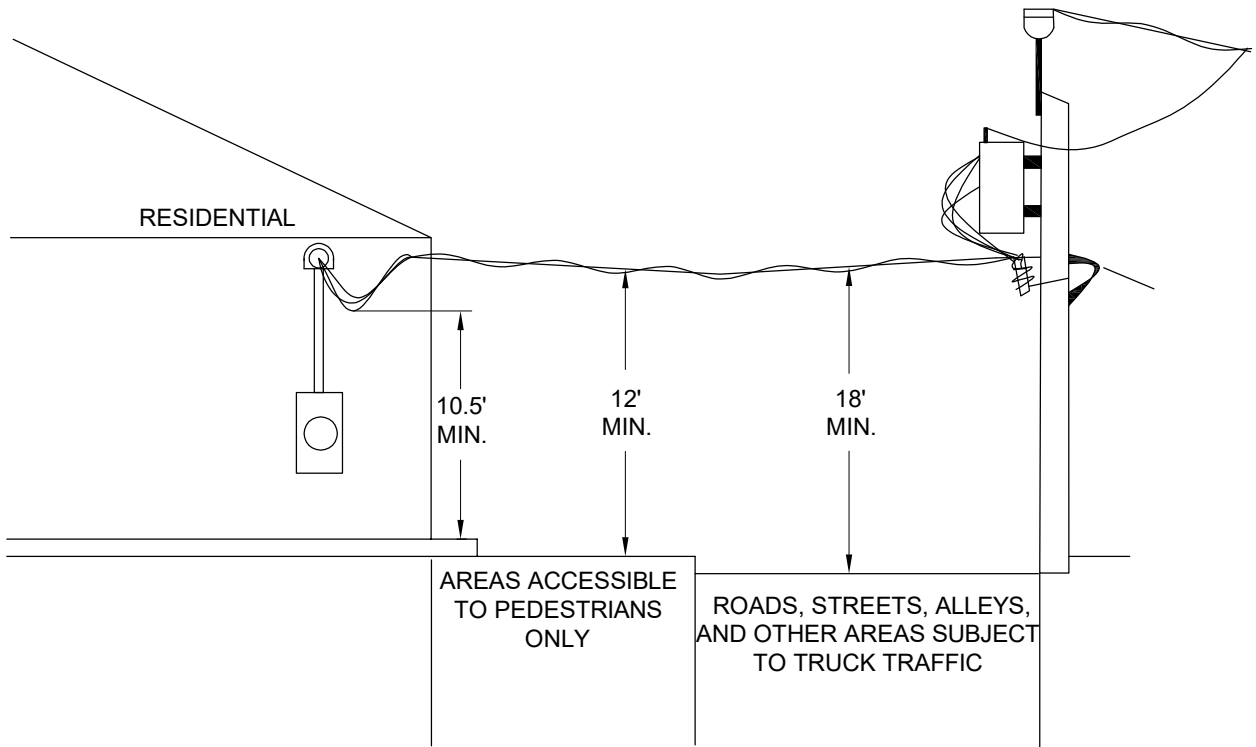

FIGURE 1



**401.0-2 CLEARANCE ABOVE GROUND - INDUSTRIAL & NON-RESIDENTIAL**

THESE MINIMUM CLEARANCES APPLY TO THE LOWEST POINT OF SERVICE DROP SAG

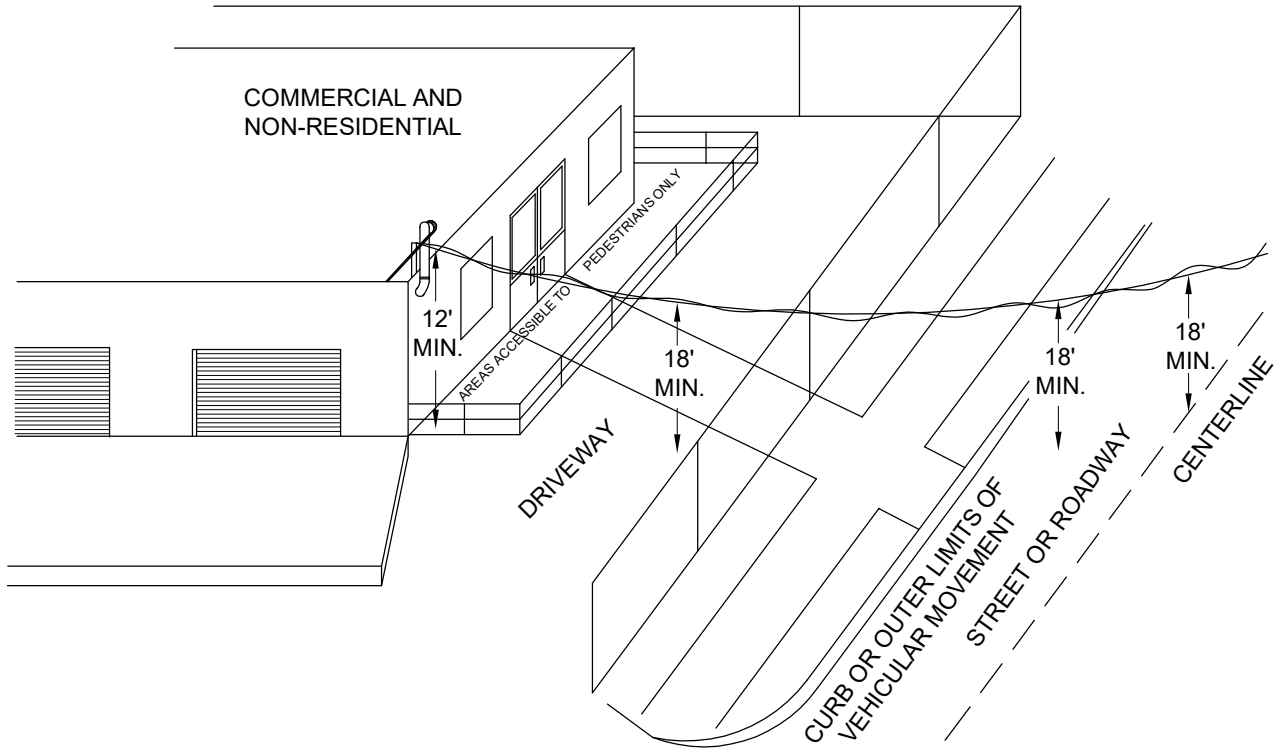
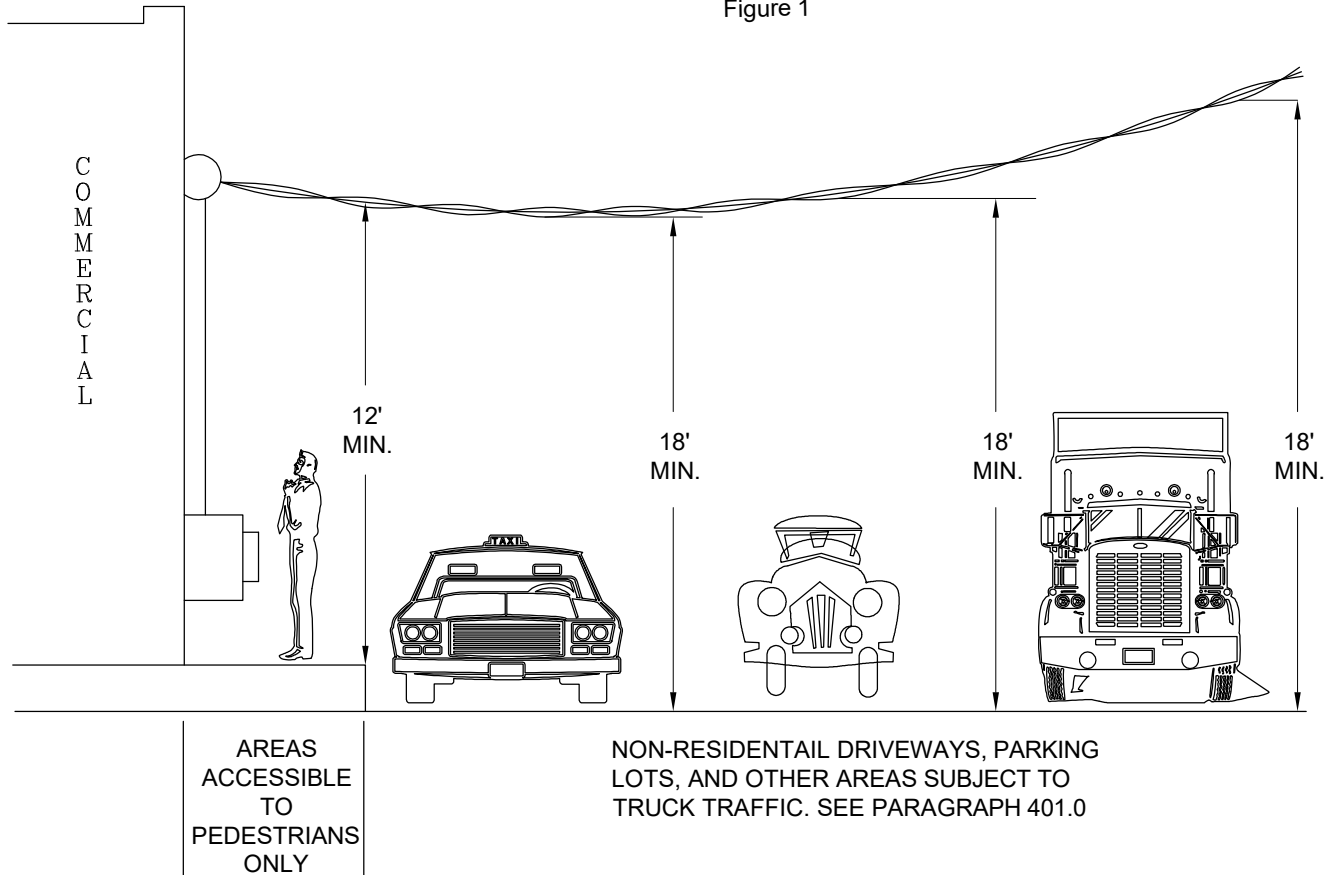
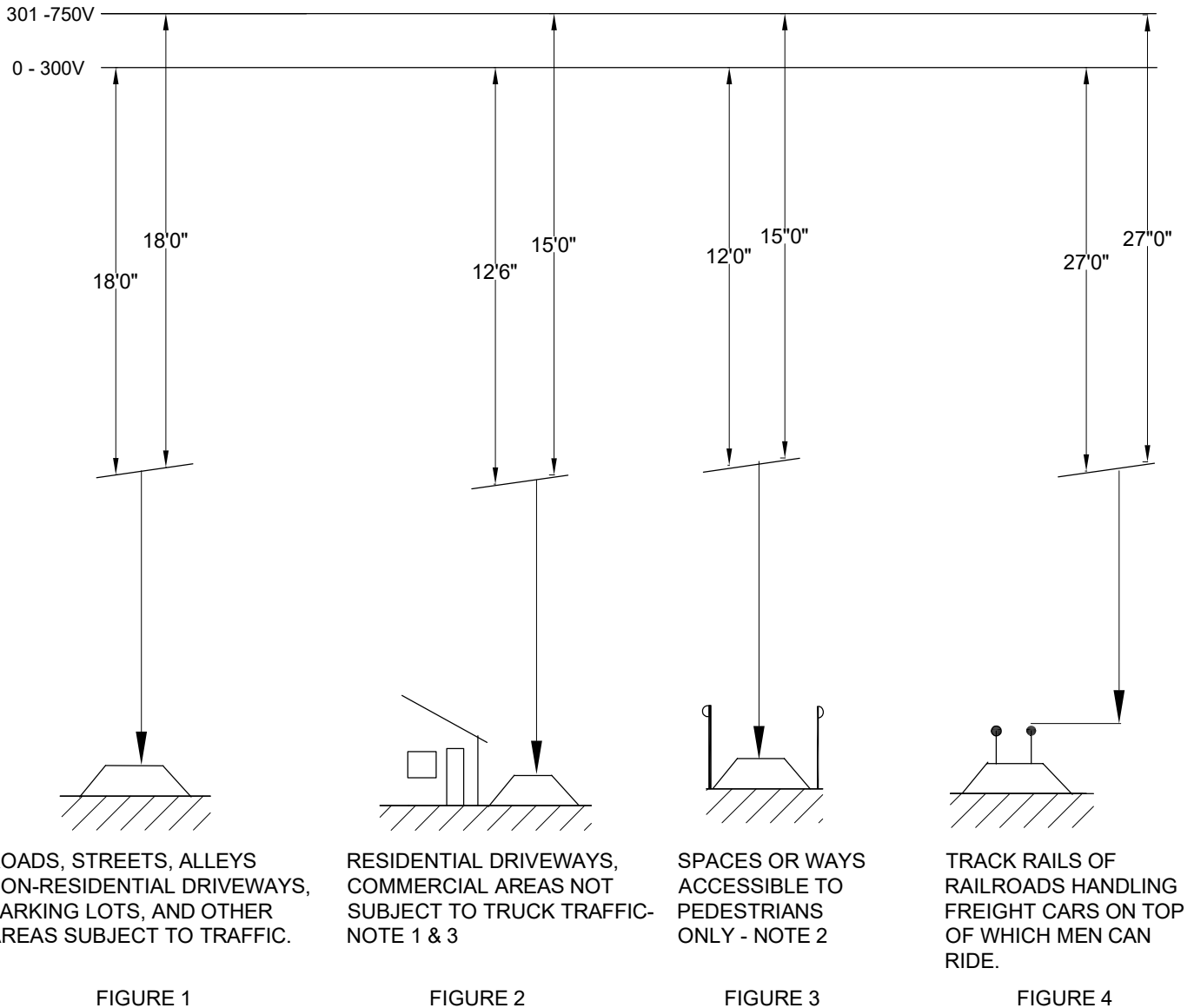

Figure 1



**401.0-3 CLEARANCE ABOVE GROUND**



**NOTES:**

1. TRUCKS ARE DEFINED AS ANY VEHICLE EXCEEDING 8 FEET IN HEIGHT.
2. IF ACCESSIBLE TO EQUESTIRIANS, USE FIGURE 1.
3. TRUCK HEIGHT MUST BE PHYSICALLY RESTRICTED.

**401.1 MINIMUM VERTICAL CLEARANCE (SWIM POOLS)**

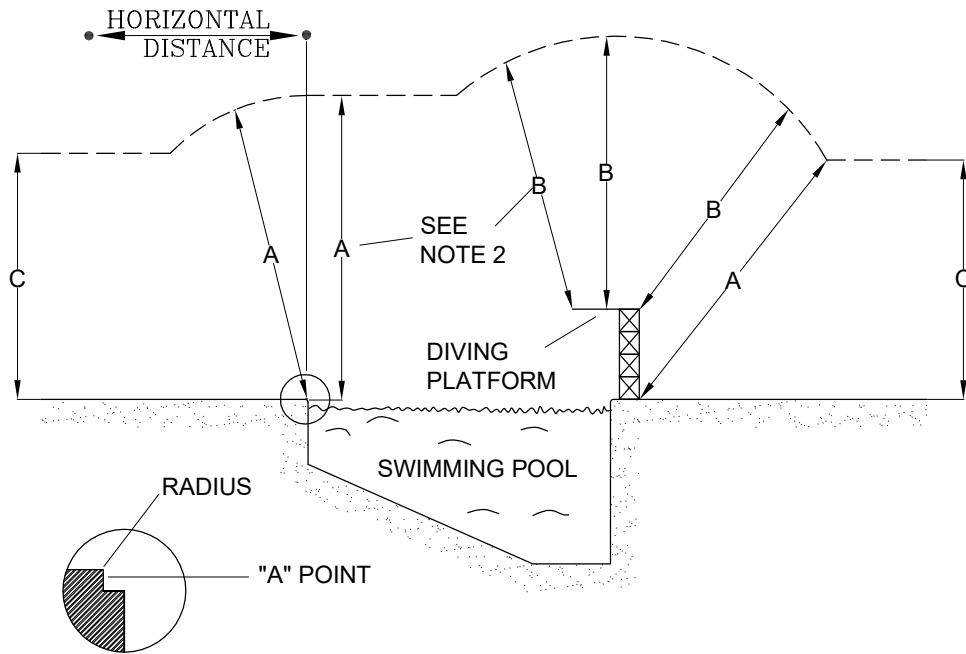

VOLTAGE PHASE TO GROUND	DIMENSION "A" VERTICAL CLEARANCE OVER POOL OR RADIAL CLEARANCE FROM EDGE OF POOL OR DIVING PLATFORM	DIMENSION "B" CLEARANCE IN ANY DIRECTION TO DIVING PLATFORM OR TOWER	DIMENSION "C" VERTICAL CLEARANCE OVER ADJACENT LAND
50KV – 470KV	26'-0" + NOTE 7	26'-0" + NOTE 7	AS REQ'D BY 401.0-3
22KV – 50KV	26'-0"	18'-0"	AS REQ'D BY 401.0-3
750V – 22KV	25'-0"	17'-0"	AS REQ'D BY 401.0-3
0 – 750V OPEN	23'-0"	15'-0"	AS REQ'D BY 401.0-3
0 – 750 MULTIPLEX W/ MULTIGRND NEUT	23'-0"	15'-0"	AS REQ'D BY 401.0-3
GUY WIRE AND COMMUNICATIONS	22'-0"	14'-0"	AS REQ'D BY 401.0-3

**NOTES:**

1. All voltages are phase-to-ground.
2. When Dimension "A" is greater than the sum of Dimension "B" plus the diving platform height, use Dimension "A".
3. Minimum clearances must be maintained from neighboring services.
4. Dimensions A and B do not apply when conductors are greater than 10' minimum horizontally from edge of pool and diving platform.
5. The swimming pool clearances shown above apply to all types of swimming areas including above and below ground pools, and spas.
6. These dimensions shall also comply with local municipal requirements.
7. Increase clearances 0.4 inch per KV for all voltage in excess of 50KV. This 0.4 inch adder shall be increased 3 percent for each 1000 feet in excess of 3300 feet elevation. Add 5 percent to all nominal voltages over 50KV when calculating increased clearances.

**401.2 HORIZONTAL CLEARANCES FROM BUILDINGS**

Conductors shall have a horizontal clearance of not less than 3 feet from buildings. For clearances from balconies, windows, fire escapes, doors, etc., see Paragraph 401.7.

---

**401.3 CLEARANCES OVER BUILDINGS AND STRUCTURES**

Service drop conductors shall not be readily accessible. When not in excess of 600 volts, they shall conform to the following: It shall be the customer's responsibility to provide a point of attachment so APS service drop conductors meet these requirements.

**Clearance Over Roof:** Conductors shall have a clearance of not less than 8 ft. from the highest point of roofs over which they pass, with the following exceptions:

Exception No. 1: Where the voltage between conductors does not exceed 300 and the roof has a slope of not less than 4 inches in 12 inches the clearance may be not less than 3 feet.

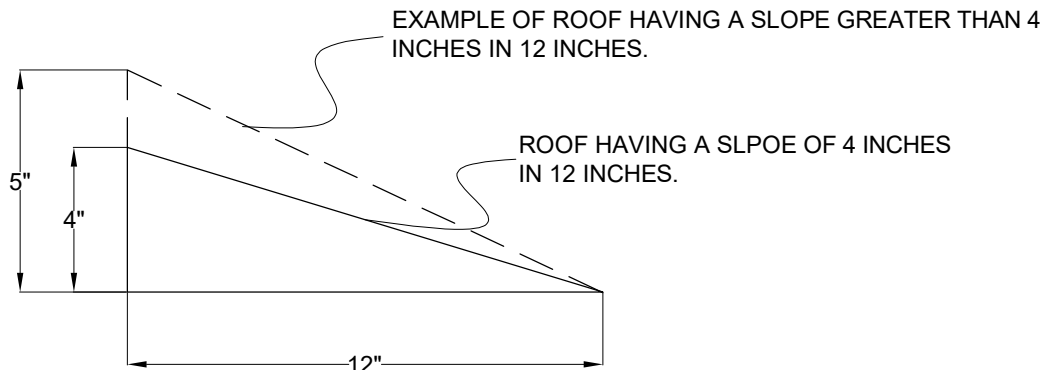

The intent of this exception is that where the roof has a slope 4 in. in 12 in. or greater it is considered difficult to walk upon and the height of conductors could then be less than 8 ft. from the highest point over which they pass but in no case less than 3 ft. except as permitted in Exception 2.

Exception No. 2: Service drop conductors of 300 volts or less between conductors where not more than 4 ft. of service-drop conductors pass above the roof for the purpose of terminating at a (through-the-roof) service raceway or approved support may be maintained at a minimum of 18 inches from any portion of the roof over which they pass. (Illustrated on Paragraph 401.3-1, Figure 2).



401.3-1 CLEARANCE OVER BUILDINGS AND STRUCTURES

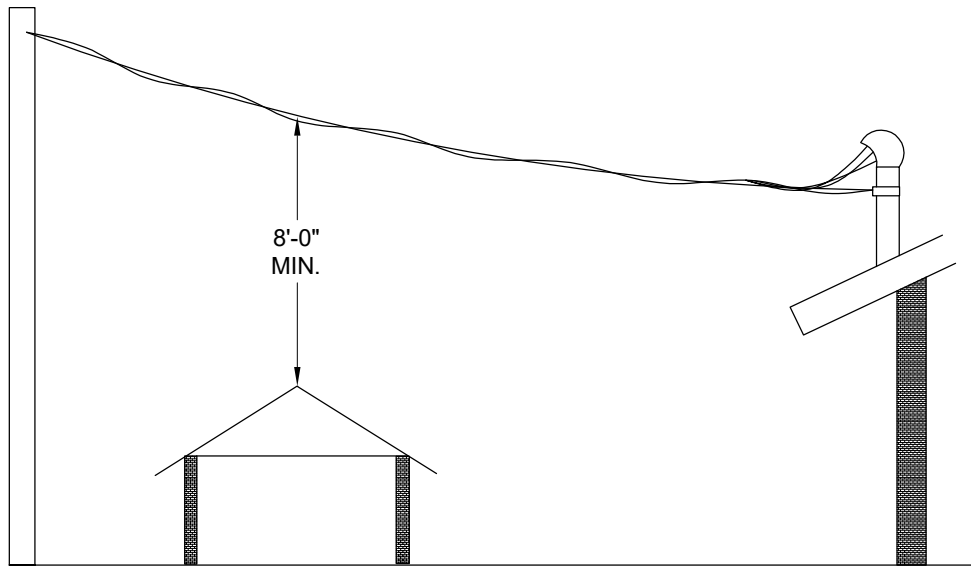
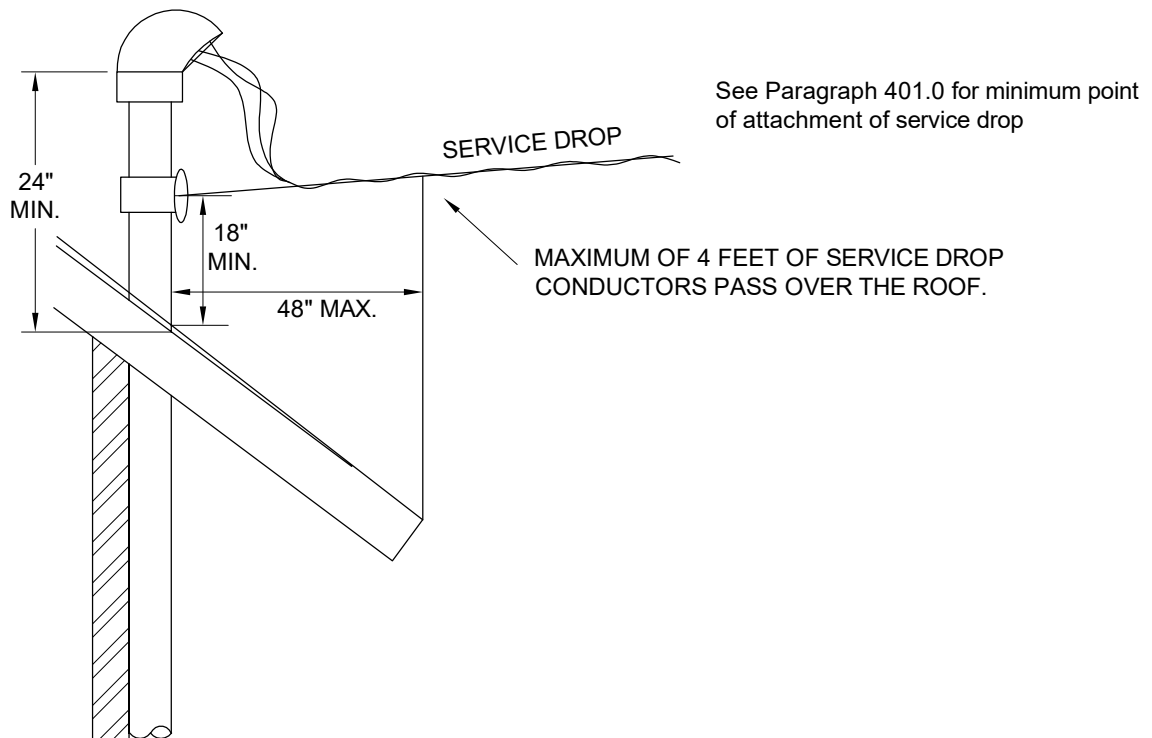

FIGURE 1

Clearance above residential, non-residential or industrial buildings on premises served or adjacent premises; OTHER THAN THE BUILDING SERVED. See Paragraph 401.3 for possible exceptions



Service entrances shall not be located within a roofed-over area necessitating APS personnel to walk on, or place a ladder on roof to make attachment to riser conduit or support, and to connect Customer's service.

#### 401.4 POINT OF ATTACHMENT STRUCTURE

An attachment structure is a support for the purpose of providing a higher point of attachment for the service drop than is provided by the building itself. It may be constructed of rigid galvanized steel pipe or galvanized angle iron. When an attachment structure is necessary to maintain the required clearances, it shall be of a type satisfactory to APS and meet all applicable codes. Such a structure shall be installed and maintained at the expense of the property owner or customer and be of sufficient strength to support the service drop wires and service attachment. The service entrance conduit may be used as and considered to be, an attachment structure; in which case the riser shall be not less than 1 1/2" galvanized rigid steel conduit or IMC. (See Paragraph 400.1) EMT or Plastic shall not be used.

##### 401.4-1 ATTACHMENT STRUCTURE (BRACING RISERS)

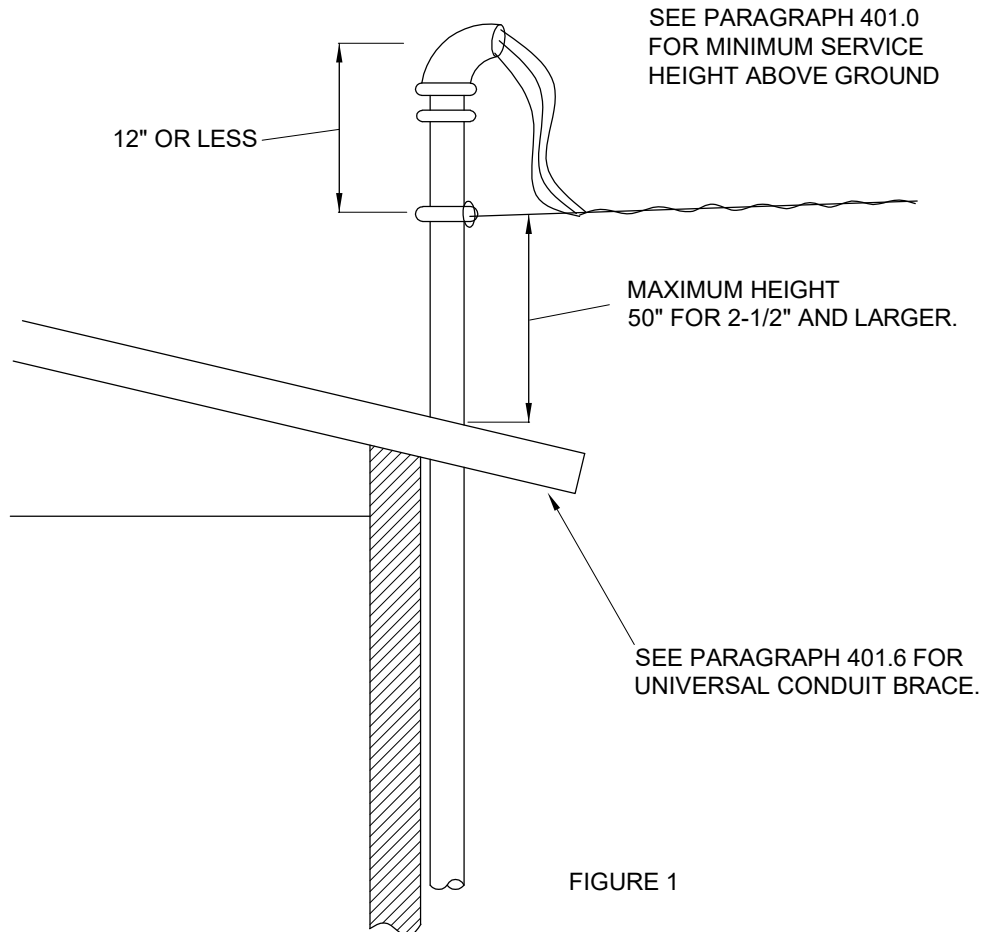

Where the service conduit riser is used as a mast for supporting the service drop, the point of attachment shall not be higher than 50" above the roof unless substantially braced (not guyed) on the roof to provide sufficient strength to support the strain of the service conductors, and to permit a man to work safely from a ladder bearing against the conduit (See Paragraph 401.5 for alternative to bracing for residential).

401.4-1 ATTACHMENT STRUCTURE (CONT.)

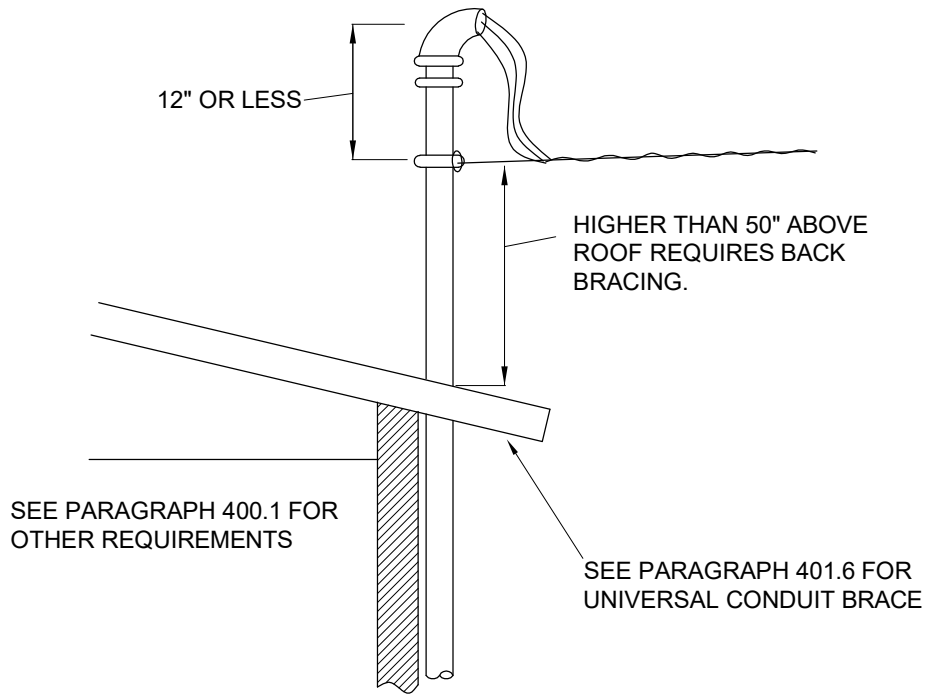

**BACK BRACING:** Risers that require back bracing shall be braced against the pull of the service drop conductors. Back bracing shall consist of two steel members installed at approximately a 90 degree spread. Minimum size braces shall be 3/4" rigid galvanized steel pipe or 1 1/4" x 1 1/4" x 1/8" steel angle.

**EXCEPTION:** Residential and non-residential, 200 ampere service or less: 3/4" electrical metallic tubing (EMT) may be used for back braces if used to pull against the load as shown in Figure 2 and 4, Paragraph 401.4-1. Push braces must be rigid steel as listed above.

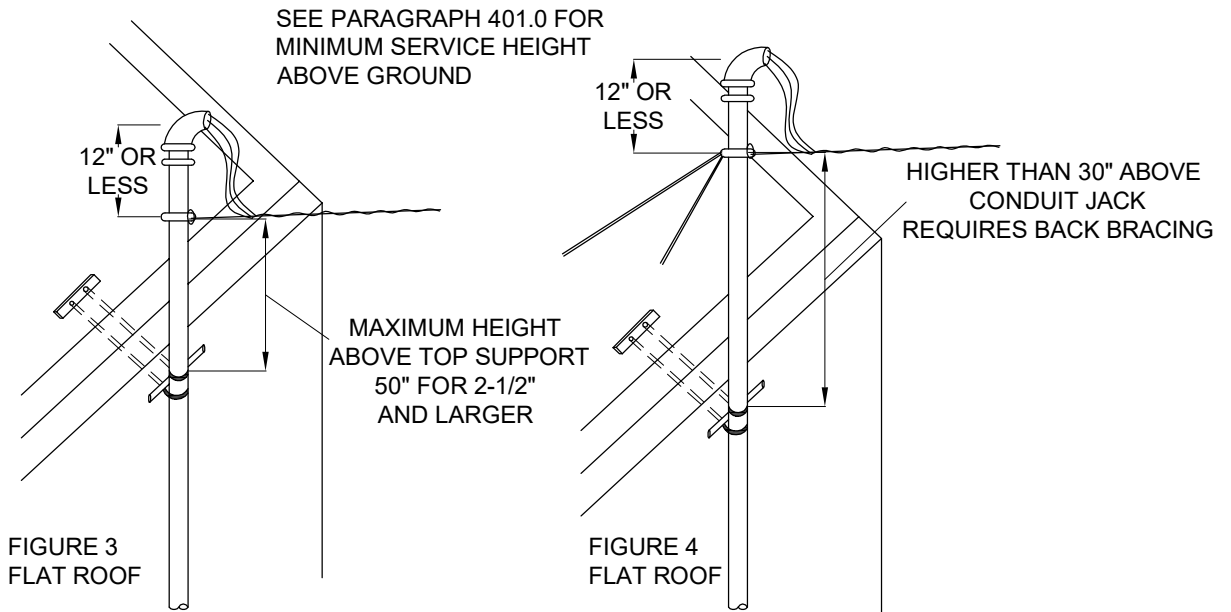

**401.5 ALTERNATE METHOD FOR POINT OF ATTACHMENT (BLOCK STRUCTURE)**

This method of service attachment is acceptable to APS if point of attachment is no higher than 50" above the roof. Check the local municipal inspection agency for acceptance.

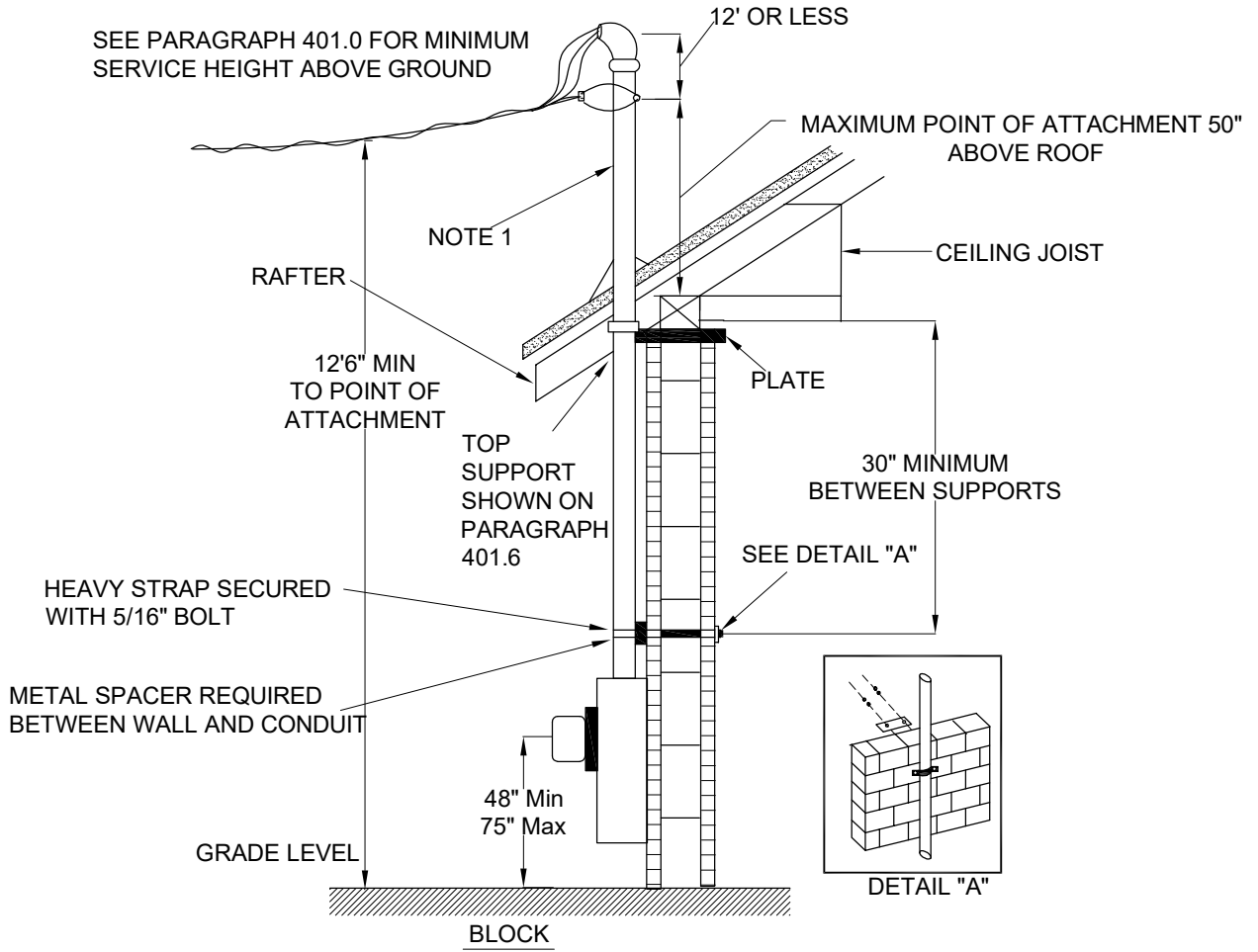

FIGURE 1

**NOTES:**

1. Riser to be minimum 2-1/2" rigid steel conduit or IMC. EMT or Plastic shall not be used, no thread less connection can be used.
2. No couplings are permitted above the highest brace.
3. APS will not be responsible for any damage to the building caused by rain or structural failure.
4. If point of attachment is higher than 50" above the roof then back bracing is required (See Paragraph 401.4-1).
5. Maximum service length for this installation is 100 feet.
6. See Section 300, Paragraph 301.16 for Electric to Gas clearances.

#### 401.5-1 ALTERNATE METHOD FOR POINT OF ATTACHMENT (WOOD FRAME STRUCTURE)

This method of service attachment is acceptable to APS if point of attachment is no higher than 50" above the roof. Check the local municipal inspection agency for acceptance above.

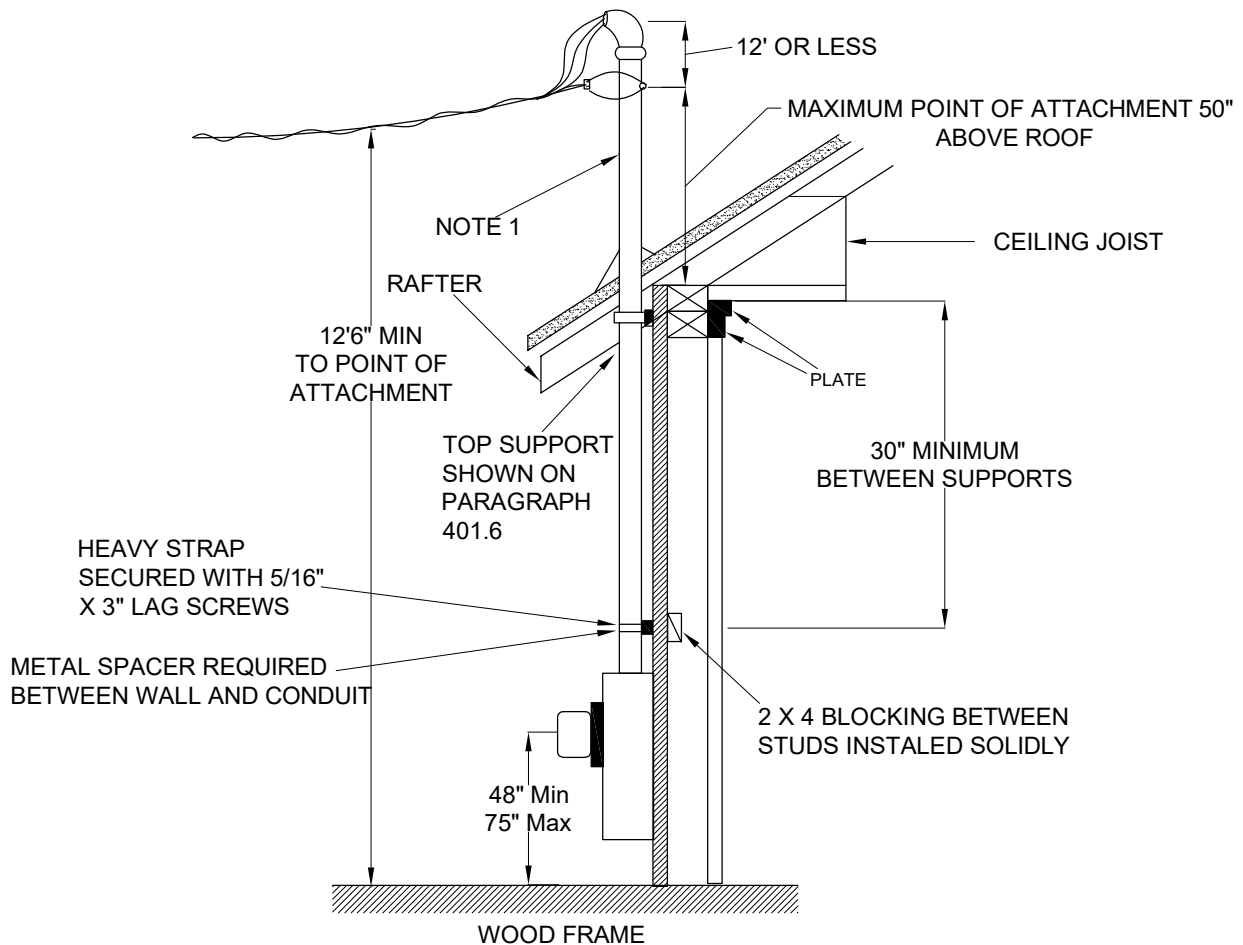
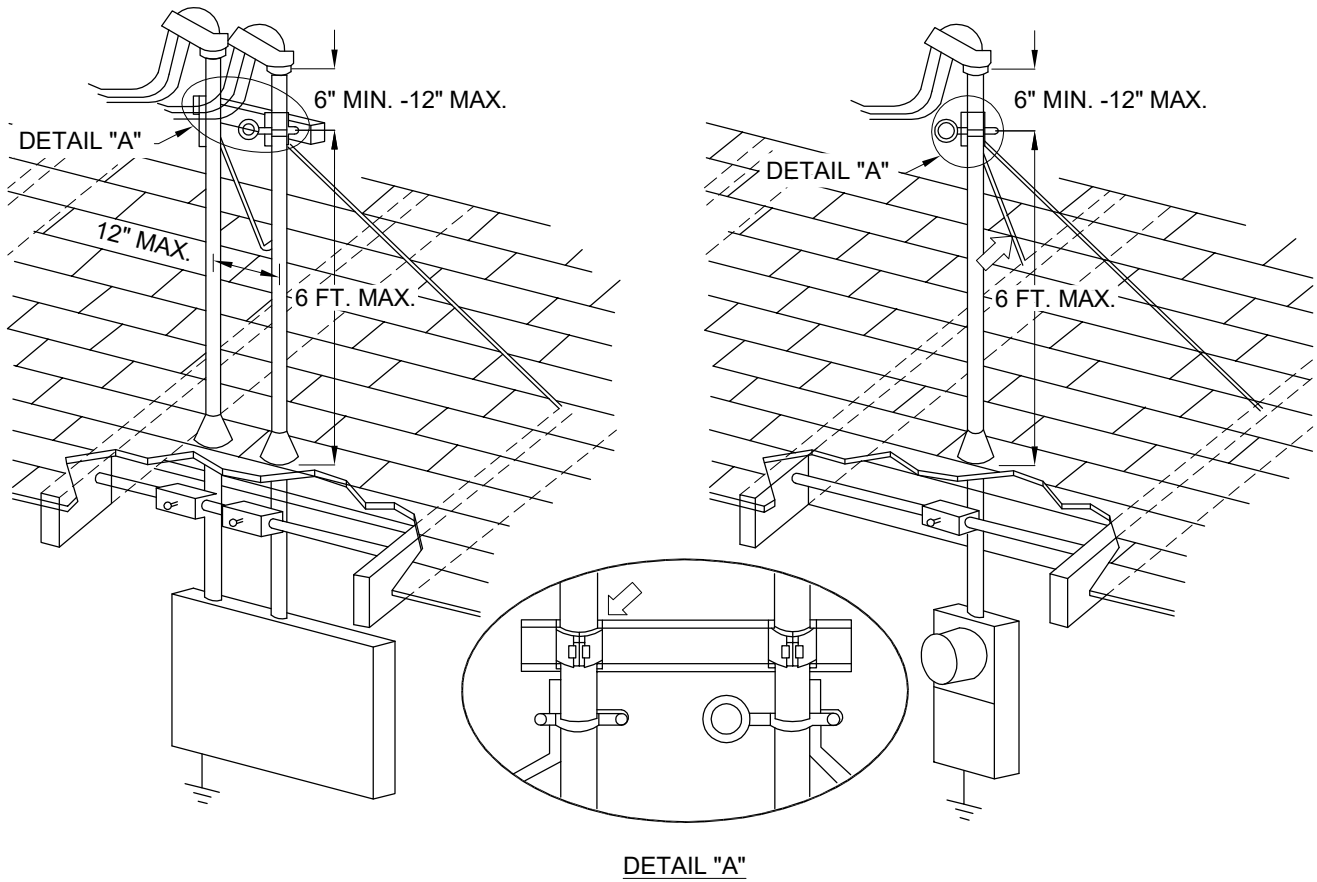

FIGURE 1

#### NOTES:

1. Riser to be minimum 2-1/2" rigid steel conduit or IMC. EMT or Plastic shall not be used, no thread less connection can be used.
2. No couplings are permitted above the highest brace.
3. APS will not be responsible for any damage to the building caused by rain or structural failure.
4. If point of attachment is higher than 50" above the roof then back bracing is required (See Paragraph 401.4-1).
5. Maximum service length for this installation is 100 feet.
6. See Section 300, Paragraph 301.16 for Electric to Gas clearances.

401.6-1 UNIVERSAL SERVICE DROP CONDUIT BRACE



NEED BACK BRACE IF 2" RISER IS HIGHER THAN 30" ABOVE PARAPET WALL BRACE

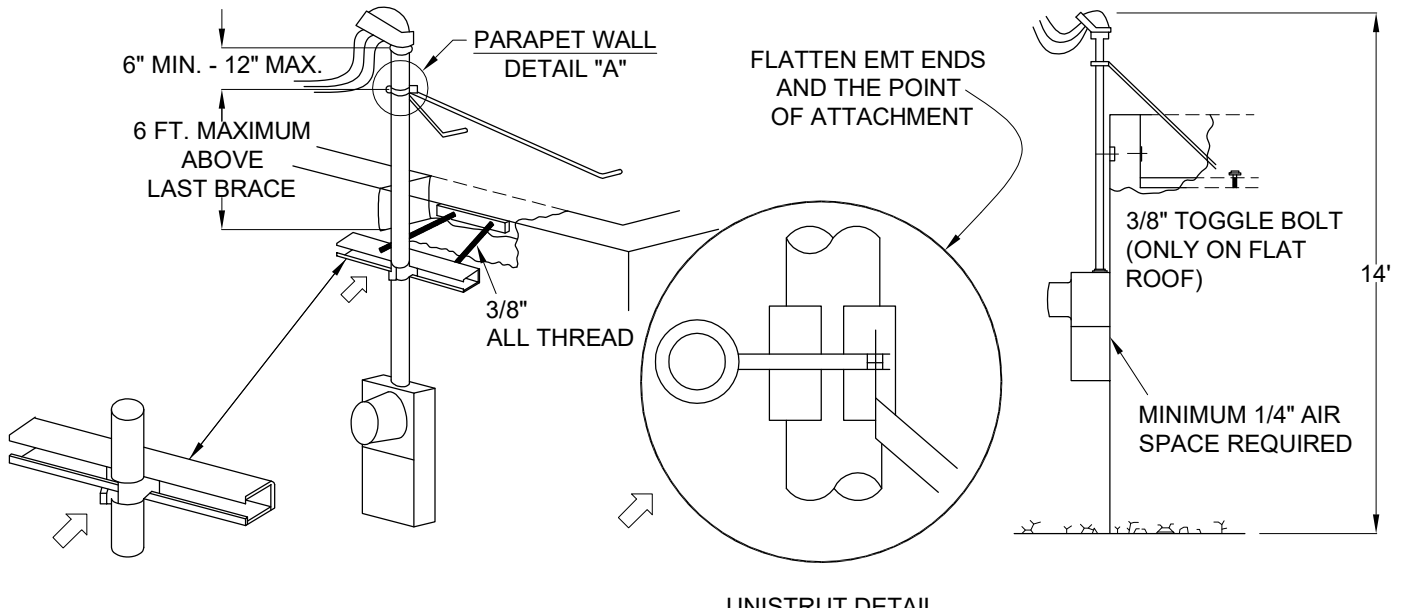

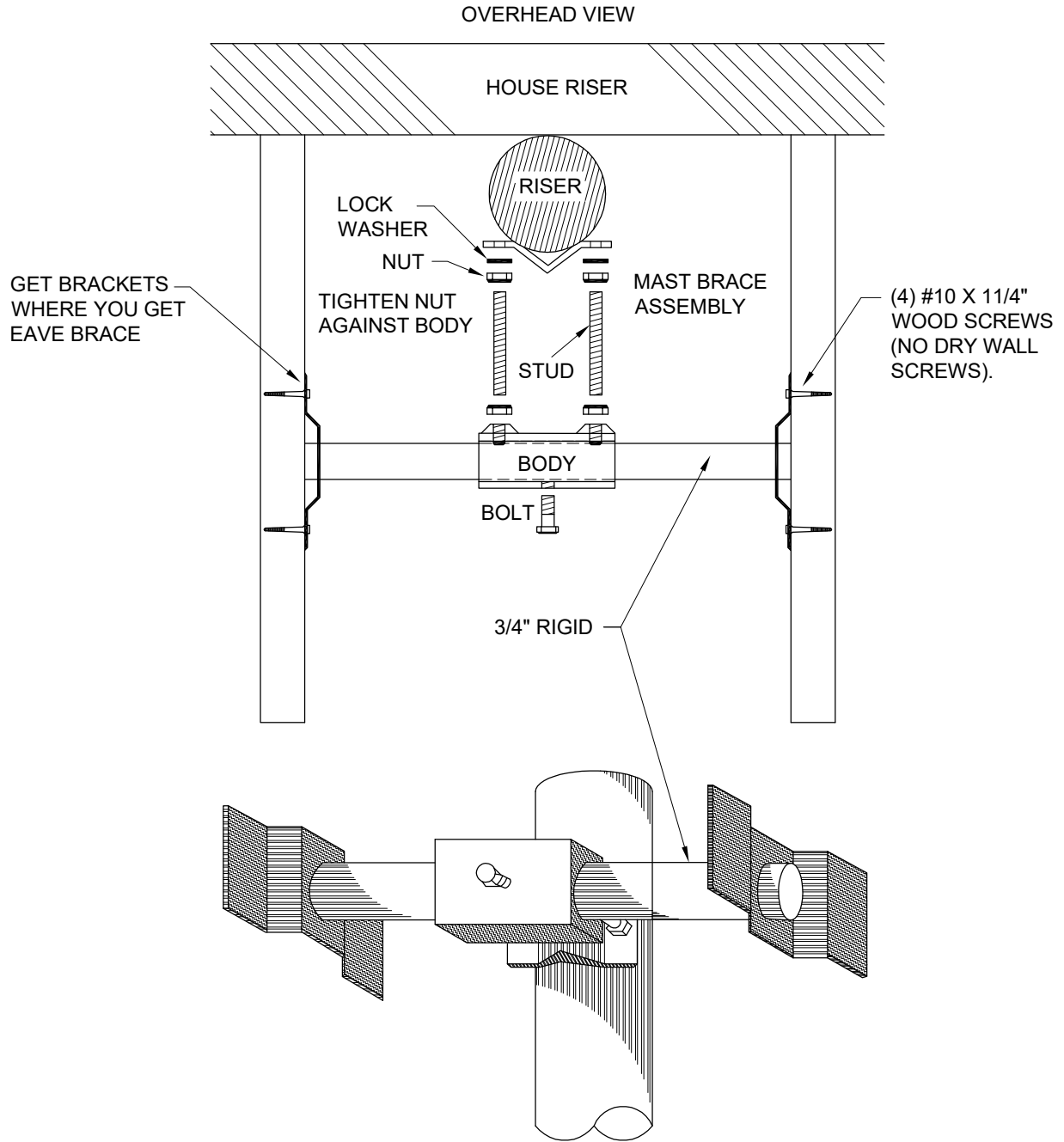

**401.7 CLEARANCE FROM DOORS, EXITS, WINDOWS, FIRE ESCAPES, BALCONIES, ETC.**

The vertical, horizontal and radial service drop conductor clearance from doors, exits, windows, fire escapes, vegetation, etc., at any of which human contact might be expected, shall not be less than that specified and illustrated:

	Minimum Clearance
1. Vertically above and below surfaces of fire escapes, balconies, stairways and walkways .....	8 Feet
2. Horizontally and radially from doors, exits, windows and other openings .....	3 Feet
3. Horizontally and radially from the outer extremities of the fire escapes, balconies, stairways, satellite dishes, antennas, walkways, and other objects .....	3 Feet
4. Vegetation clearcut distance around service conductors in all directions .....	5 Feet

**CLEARANCE FROM DOORS, EXITS, WINDOWS, FIRE ESCAPES, BALCONIES, ETC.  
(For Exposed Service Conductors Only — See Note 3)**

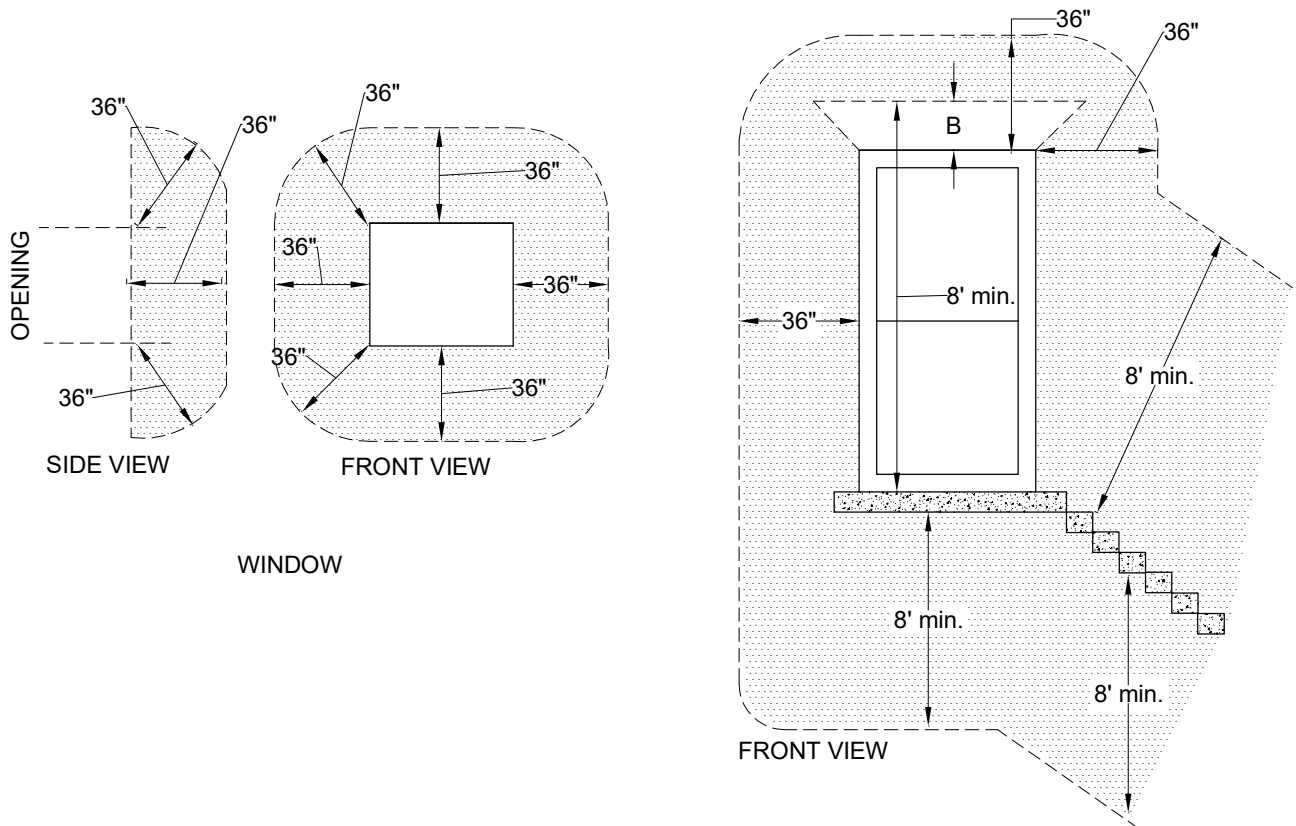

**NOTES:**

1. Service drop conductors not permitted within shaded zones.
2. Dimension "B" may be less than 36 inches, provided it is a minimum of 12 inches above opening and the minimum 8 foot vertical clearances shown are obtained.
3. Conduit and meter cans may be inside shaded areas. Service conductors, drip loops or any wire may not be inside shaded areas.
4. Vegetation management (tree work) is extremely hazardous work, particularly near energized powerlines. By law, such work nearby overhead conductors shall be undertaken only by an OSHA-defined, line-clearance arborist. Contact APS for questions or additional information.



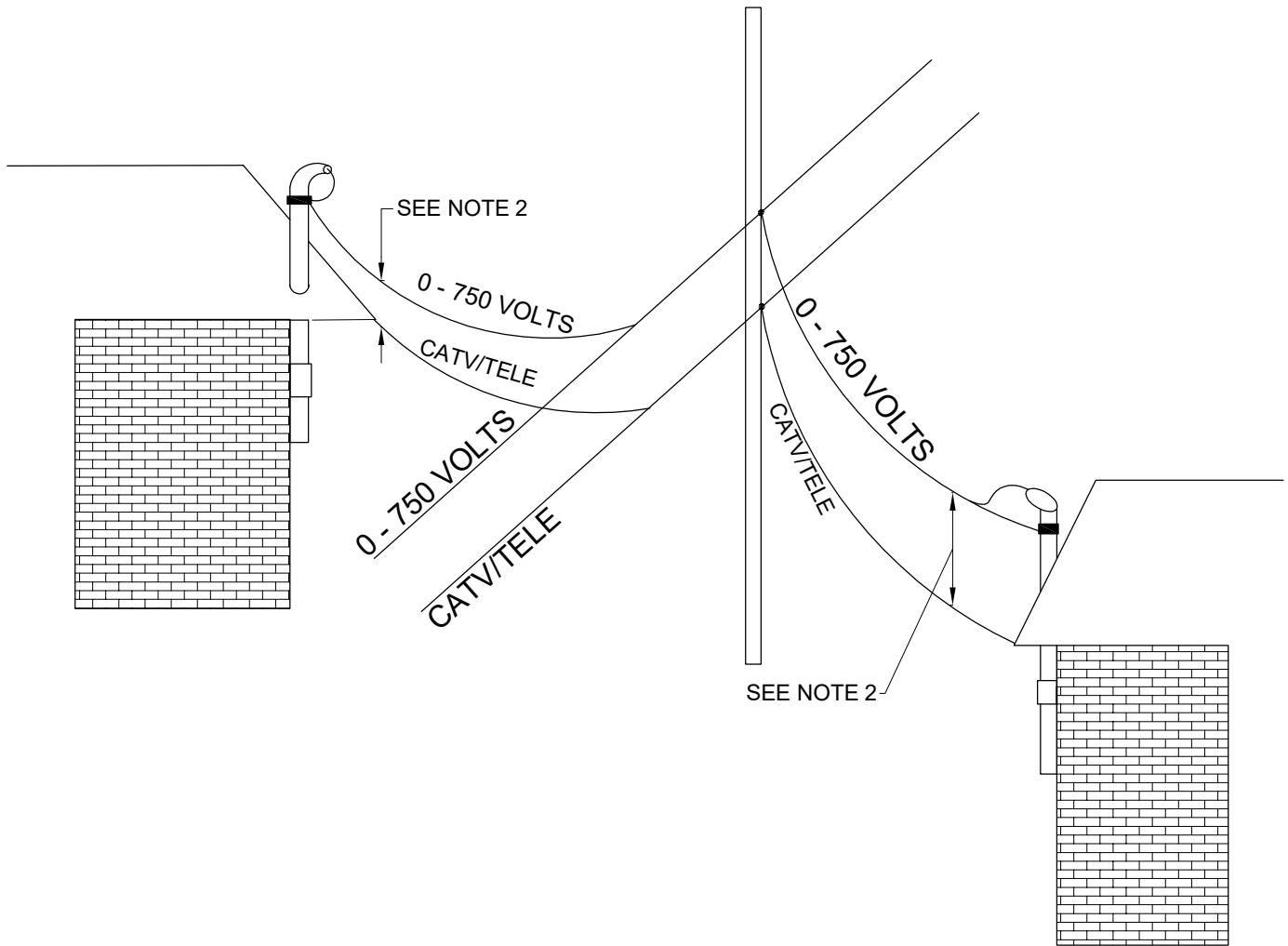

**NOTES:**

1. Voltages are phase to ground.
2. Clearance from CATV/TELCO to electric service conductors.  
 12" ----- multiplex electric service  
 30" ----- open wire electric service
3. Clearances are for any point in the service span.
4. Clearances must be maintained between electric services and all telephone/CATV cables and services. A higher point of attachment may be necessary to maintain clearances. This is especially important if the electric point of attachment is close to existing APS pole lines. Contact your local APS customer service representative if you are in doubt about proper clearances.

**401.9 TYPICAL OVERHEAD RESIDENTIAL METER INSTALLATION**  
100-225A, 1 PH, 3W, 120/240 VOLT

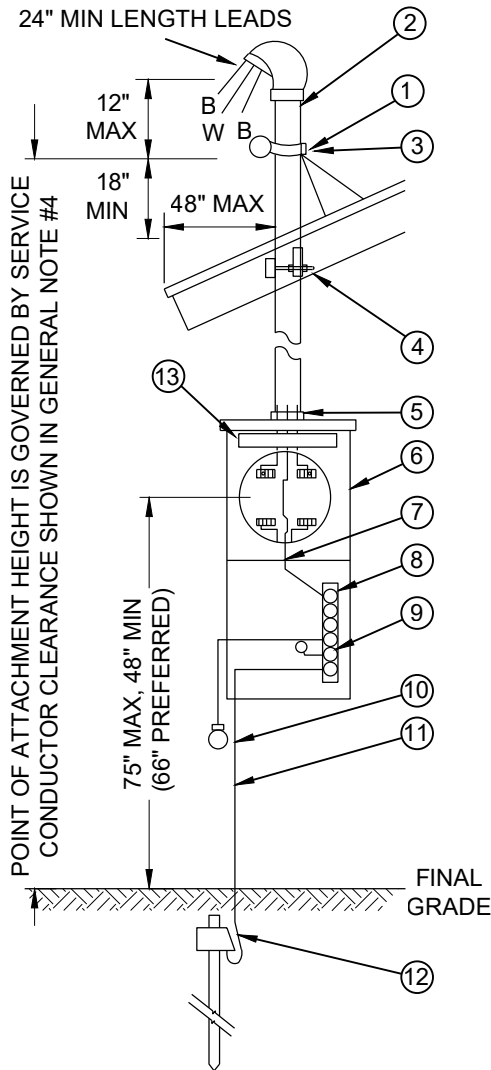

Permits and inspections are required. Please contact the governing inspection agency in your area.

**Note:** Enough wire to reach main disconnect enclosure must extend outside concrete footer.

This is a list of material for a normal overhead residential meter installation. It is not intended to be all inclusive but gives the more common requirements. All equipment shall comply with EUSERC requirements and all specifications found in the APS Electric Service Requirements Manual (ESRM). Recommended wire sizes shown below are for information only. The Local Authority Having Jurisdiction (AHJ) determines the actual sizes required.

SERVICE RATING	COPPER	ALUMINUM	WEATHERHEAD & CONDUIT
100A	#4	#2	1-1/2"
125A	#2	#1/0	1-1/2"
150A	#1	#2/0	1-1/2"
200A	#2/0	#4/0	2"
225A	#3/0	#250	2" (2-1/2" IF #250)

1. Point-of-attachment to be insulated. (ESRM 400.1)
2. Rigid metal conduit is required if service is attached to the service drop damp. If conduit is attached to building, Customer is to install a 1/2" bolt with a 2" backing washer.
3. Unbraced point-of-attachment maximum height above roof is 20" for 1-1/2" conduit and 30" for 2" and larger conduit.
4. Universal service drop brace.
5. Approved hub, must be raintight.
6. Meter socket, breaker panel must be raintight equipment. Meter socket jaws or clips shall be free of foreign material (mud, paint, plaster, etc.). **RINGLESS METER SOCKETS ARE NOT ACCEPTABLE.**
7. Neutral to be a continuous, unbroken conductor from the weatherhead to the neutral landing block.
8. Neutral landing block.
9. Install a bonding jumper or screw if the neutral landing block is insulated from the enclosure.
10. Bonding of piping systems - all interior metal piping shall be bonded to the electric grounding system. Gas piping shall be bonded on the house side of the insulating coupling.
11. The ground wire (#4 bare solid copper) shall be continuous from the neutral landing block to an approved grounding electrode system in compliance with NEC Article 250. The ground wire must be properly supported and attached to the building at 24" intervals.
12. Approved grounding electrode system.
  - a. 5/8" x 8' long ground rod and approved clamp. Entire length of rod to below grade.
  - b. 20' of bare #4 copper wire installed in concrete footer (UFER)

**GENERAL NOTES:**

1. Meter location to be specified by Company Representative.
2. If more than one meter to the premises, each meter shall be permanently identified, by the Customer, to properly identify that portion of the premises being served. Metal stamping or metal tag is required. Painted identification is not acceptable.
3. All materials or work furnished by the Customer shall be in accordance with all applicable codes or standards.

4. Minimum service height above ground (phase to ground voltages):

- a) Within Right-of-Way of roads, streets, alleys, non-residential driveways, parking lots, and other areas subject to truck traffic ..... 18'-0
- b) Service over residential driveways. (See 401.0)..... 12'-6
- c) Commercial spaces, driveways, and parking lots  
NOT subject to truck traffic ..... 12'-6
- d) Areas accessible to pedestrians only..... 12'-0

**5. Minimum attachment height is 12ft - 6in. Additional height may be required according to Authority having jurisdiction (AHJ).**



## 402.0 CUSTOMER SERVICE POLE

---

### 402.1 LOCATIONS

THE LOCATION OF CUSTOMER METER POLES SHALL BE APPROVED BY APS BEFORE SETTING.

Meters or attachments shall not be mounted on APS poles. When it is necessary for the service point of attachment and service entrance to be made to a pole instead of the residence or building, that pole is to be provided by the Customer and its height shall be great enough to give sufficient clearance for APS service wires.

---

### 402.2 REQUIREMENTS: (WOOD)

Customer provided Wood Poles shall comply with the following requirements:

1. Full length pressure treated pole per American Wood Protection Association (AWPA) Book of Standards, latest revision. This can only be done by a commercial plant specifically designed to perform this treatment. Surface applications of preservatives will not meet this requirement.
2. Any AWPA specified treatment for poles is acceptable.
3. Temporary service poles may be moved from jobsite to jobsite, but must be inspected and approved by APS prior to each installation.
4. For permanent or temporary installations, a used pole may be used as a customer service pole without being retreated, if both of the following conditions are met:
  - a.) The pole is eight years of age or less
  - b.) The butt has not been cut off, or damaged by abrasion or penetration
5. If a used pole is over eight years old, has a damaged butt, or has had the top cutoff, it may be reused provided it is sound and retreated in accordance with the following items below. Additionally, the pole must be inspected and approved by authorized APS personnel prior to being installed in place.
  - a.) If the pole is over eight years old or the butt has been cut off or damaged, the pole must be retreated by a full length pressure treatment as specified in items 1 and 2 above.
  - b.) If the top of the pole has been cut off, a commercial wood preservative must be applied to the cut to prevent water penetration and resultant pole deterioration.
6. Supplier information shall be identified on the face of the pole, using a burn brand or a non-corrosive metal tag, per Section 402.2-1.

402.2-1 CUSTOMER SERVICE POLE 0 - 300 VOLTS

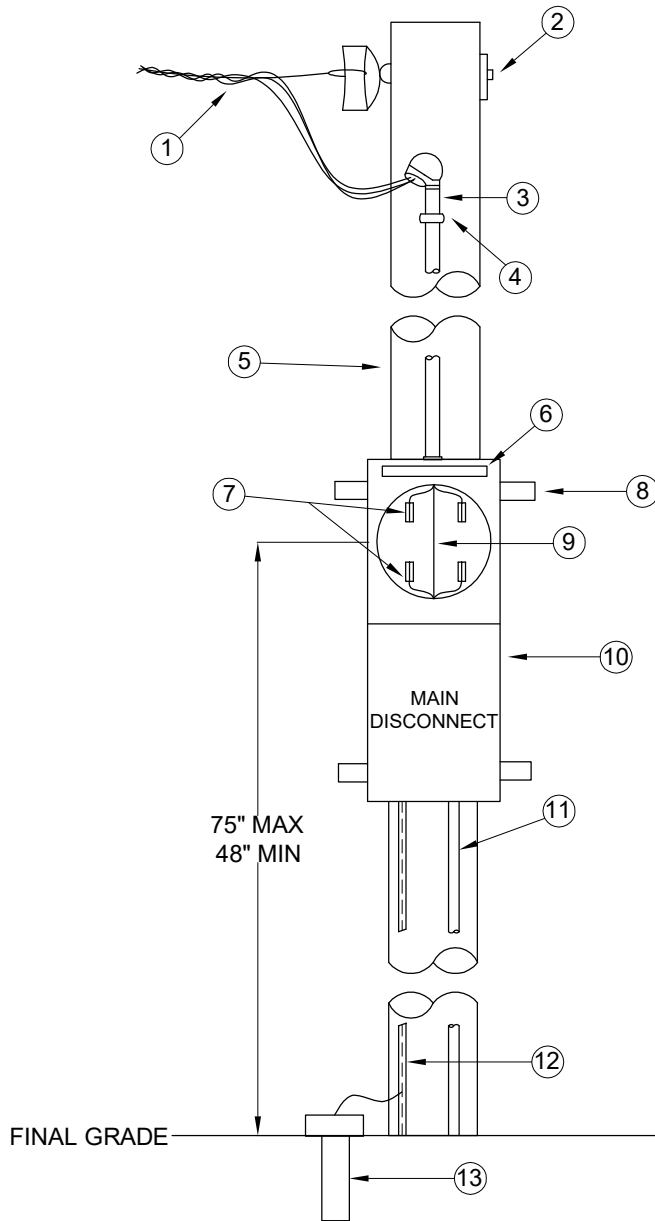

- 1.) APS SERVICE WIRES AND POINT OF ATTACHMENT CONNECTION MADE BY APS. WEATHERHEAD MUST BE WITHIN 12" OF POINT OF ATTACHMENT.
- 2.) CUSTOMER TO DRILL HOLE THROUGH POLE IN THE DIRECTION OF SERVICE DROP AND INSTALL 1/2" EYEBOLT WITH 2" SQUARE WASHER FOR SERVICE ATTACHMENT.
- 3.) ENTRANCE CONDUIT SHALL NOT BE INSTALLED ON OPPOSITE SIDE OF POLE FROM POINT OF ATTACHMENT.
- 4.) PIPE STRAP SUPPORTS NOT OVER 6'-0" APART.
- 5.) POLE FURNISHED BY CUSTOMER (SEE LOCATION - REQUIREMENTS - SIZES).
- 6.) RIVETED NON-FERROUS METAL ADDRESS LABEL. SEE 302.1 FOR LABEL REQUIREMENTS.
- 7.) WIRES TO BE CONNECTED IN METER SOCKET BY CUSTOMER.
- 8.) UNISTRUT.
- 9.) NEUTRAL SHALL NOT BE CUT.
- 10.) APPROVED ALL-IN-ONE METER PANEL.
- 11.) UNDERGROUND CONDUIT TO CUSTOMER'S LOAD.
- 12.) APPROVED GROUND WIRE.
- 13.) APPROVED GROUND ROD AND CLAMP.

NOTES:

1. See Paragraph 401.0 for minimum heights.
2. Drip Loop conductors minimum height is 10 feet 6 inches.
3. See Paragraph 402.3 for wood and steel pole sizes.
4. Weatherhead must be located within 12 inches of point of attachment.
5. Wood poles are exempt from insulated point of attachment requirement.
6. Unistrut shall be mounted to pole using a 1/2" minimum galvanized through bolt with a 1 1/2" backing and a lock nut. Meter panel shall be attached to unistrut using 1/4" minimum through bolts. Pole shall be notched to the depth of the unistrut (1" unistrut maximum).

402.2-2 CUSTOMER SERVICE POLE

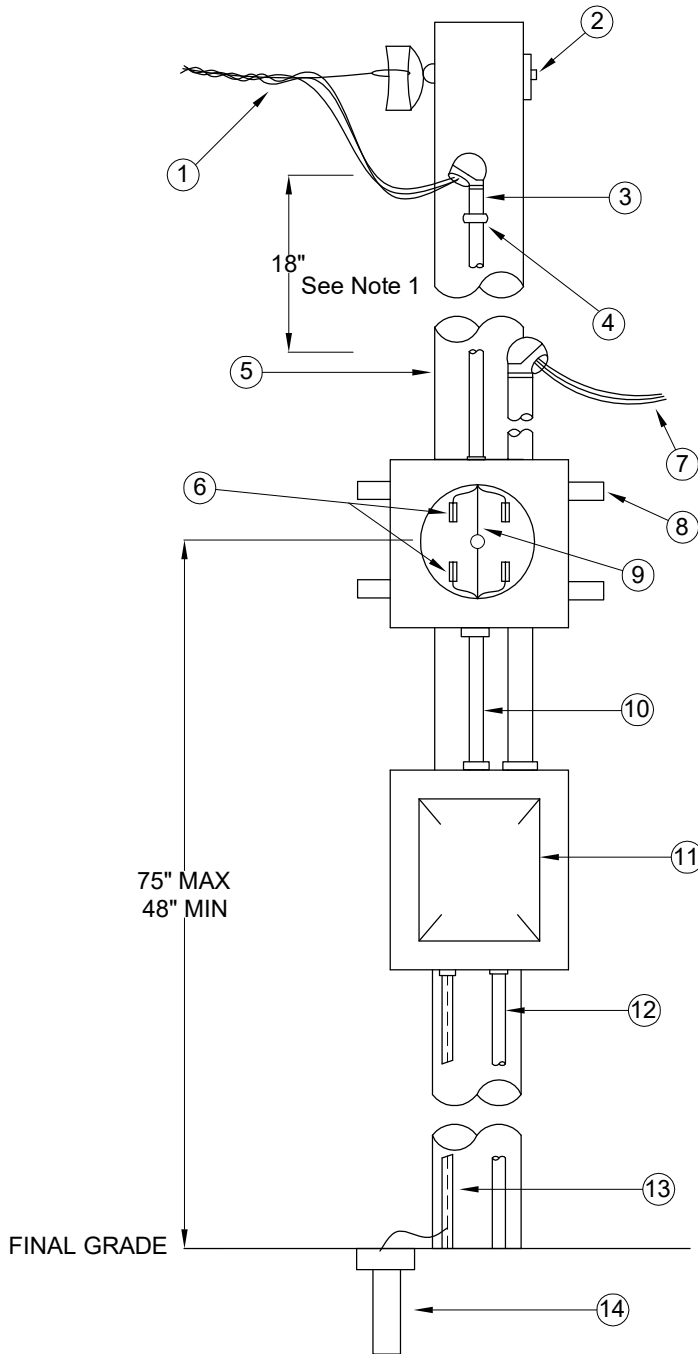

- 1.) APS SERVICE WIRES AND POINT OF ATTACHMENT CONNECTION MADE BY APS. WEATHERHEAD MUST BE WITHIN 12" OF POINT OF ATTACHMENT.
- 2.) CUSTOMER TO DRILL HOLE THROUGH POLE IN THE DIRECTION OF SERVICE DROP AND INSTALL 1/2" EYEBOLT WITH 2" SQUARE WASHER FOR SERVICE ATTACHMENT.
- 3.) ENTRANCE CONDUIT SHALL NOT BE INSTALLED ON OPPOSITE SIDE OF POLE FROM POINT OF ATTACHMENT.
- 4.) PIPE STRAP SUPPORTS NOT OVER 6'-0" APART.
- 5.) POLE FURNISHED BY CUSTOMER (SEE 402.2-3 & 402.3 FOR REQUIREMENTS).
- 6.) WIRES TO BE CONNECTED IN METER SOCKET BY CUSTOMER.
- 7.) TO CUSTOMER'S LOAD.
- 8.) UNISTRUT.
- 9.) NEUTRAL SHALL NOT BE CUT.
- 10.) 4" NIPPLE MINIMUM GROUND BUSHINGS AND BONDING REQUIRED ON ALL UNFUSED NIPPLES.
- 11.) APPROVED ENCLOSED BREAKER PANEL.
- 12.) ALTERNATE UNDERGROUND CONDUIT TO CUSTOMER'S LOAD.
- 13.) APPROVED GROUND WIRE.
- 14.) APPROVED GROUND ROD AND CLAMP.

**NOTES:**

1. Minimum clearance from the APS line-side wires to the Customer's load-side wires, or Customer attachments, shall be 18 inches.
2. No Customer facilities shall be located above APS facilities.
3. Wood poles are exempt from insulated point of attachment requirement.
4. Unistrut shall be mounted to pole using a 1/2" minimum galvanized through bolt with a 1 1/2" backing and a lock nut. Meter panel shall be attached to unistrut using 1/4" minimum through bolts. Pole shall be notched to the depth of the unistrut (1" unistrut maximum).

402.2-3 CUSTOMER SERVICE POLE REQUIREMENTS (WOOD)

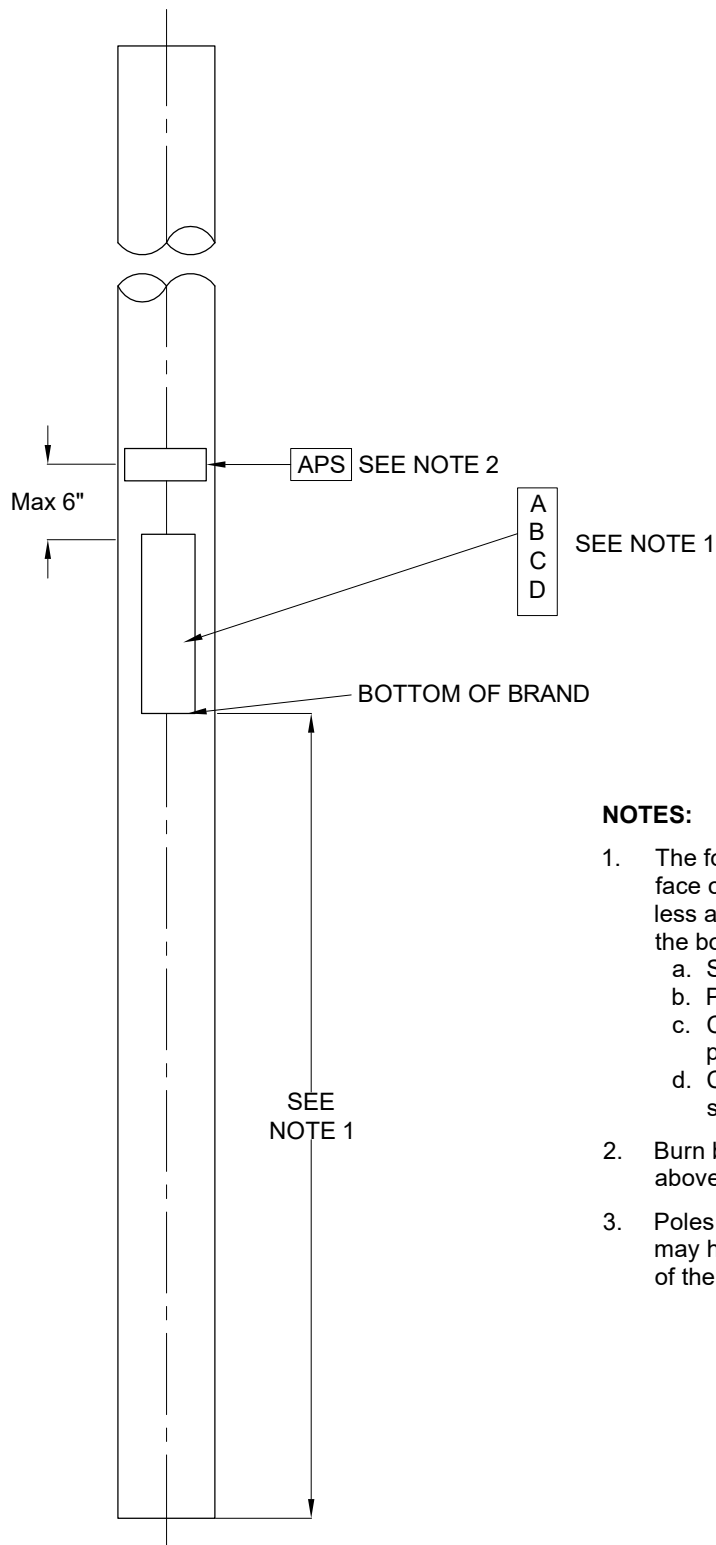

**NOTES:**

1. The following information shall be burn branded on the face of the pole at a distance of  $10' \pm 2''$  for poles 50' and less and  $14' \pm 2''$  for poles 55' and greater from the butt to the bottom of the brand.
  - a. Supplier's Code or Trade Mark.
  - b. Plant location and the Year of Treatment.
  - c. Code letters denoting the pole species and preservative used.
  - d. Circumference Class numeral and numerals of showing length of the pole.
2. Burn brand "APS" on the face of the pole 6" maximum above the suppliers trade mark.
3. Poles purchased between May 1958 and December 1991 may have the pole brand stamped at 12 feet from the butt of the pole.

**WOOD POLE MARKING**

(per APS T&D Material Specification MS-1913)

**402.3 CUSTOMER SERVICE POLE - SIZES**

**(WOOD POLES)**

Minimum Attachment Clearance Above Ground (Feet)	Length Of Pole (Feet)	Minimum Circumference At Top (Inches)	Minimum Circumference At 6 Feet From Butt (Inches)	Minimum Setting Depth (Feet)
12.5	18**	19	24	4
15	20	19	28	4
18	25	19	28	5
24	30	19	30	5

**(STEEL POLES)**

Clearance Above Ground (Feet)	Length Of Pole (Feet)	Minimum Setting Depth (Feet)*	Minimum Diameter (Inches)	Minimum Gauge (Inches)
12.5	16	3	3.5	0.226
16	20**	4	4	0.237
20	25	5	5	0.258
25	30	5	5	0.258

\* Minimum setting depth in rock is 3' when approved by APS.

\*\* Minimum length for joint use with communications.

**NOTES:**

1. Point of attachment of conductors for steel poles shall be insulated.
2. Circumferences are for Class 5 Ponderosa Pine.
3. For Steel Poles, the portion of the steel pole that is below grade, up to a minimum of 6" above grade, shall be factory coated or shall be half-lapped with minimum 20 mil. tape suitable for its use, to a total thickness of 40 mil. The tape shall be labeled to include the thickness (20 mil.) and the manufacturer's name. Pole-wrapping tape to be installed in accordance with tape manufacturer specifications.
4. Steel poles shall be of a single continuous piece construction.

**402.4 SERVICE RISER CONDUCTORS**

Wires from the weatherhead and from the main service switch shall be properly made-up and connected to the meter socket - by the Customer. The neutral wire shall be bonded to the meter socket at the "lay-in" lug on the socket (It shall not be cut within the socket enclosure. See Paragraph 400.2 for identification of conductors).

**402.5 TYPICAL POLE-MOUNTED METER INSTALLATION FOR RESIDENTIAL / COMMERCIAL OR TEMPORARY SERVICE**  
 100-225A, 1 PH, 3W, 120/240 VOLT

Permits and inspections are required. Please contact the governing inspection agency. This is a list of material for a normal pole-mounted meter installation. It is not intended to be all inclusive but gives the more common requirements. All equipment shall comply with EUSERC requirements and all specifications found in the APS Electric Service Requirements Manual (ESRM).

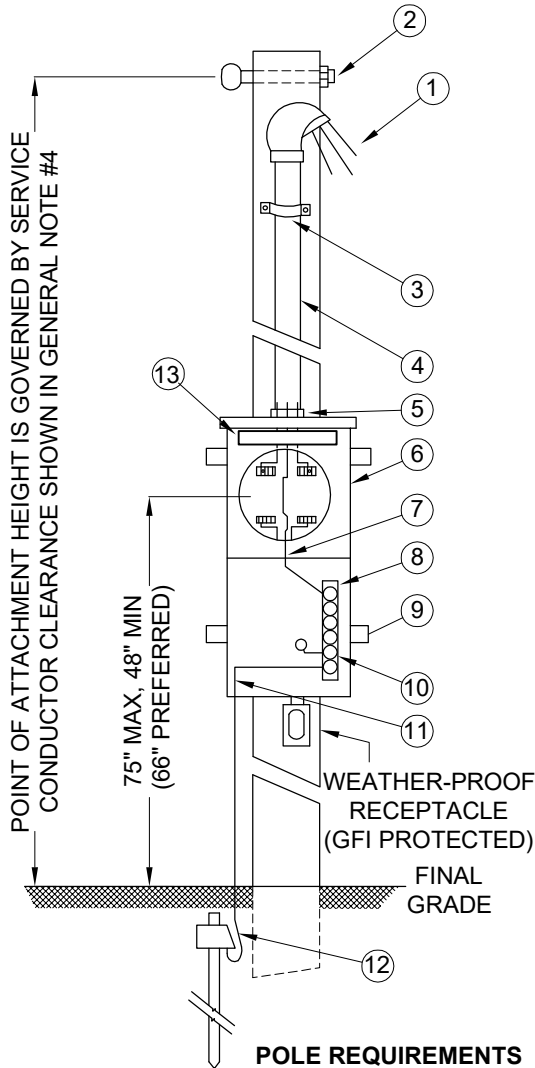

1. Weatherhead-conductor leads to extend a minimum of 24" beyond the weatherhead.
2. 1/2" eyebolt with a 2" backing washer. Must be located within 12" of the weatherhead & shall be point of attachment. Customer to drill hole through pole in the direction of service drop. Insulated point of attachment required if steel pole is used.
3. Conduit support. Not over 6' apart.
4. Rigid or IMC metal conduit.
5. Approved hub must be rain-tight.
6. Meter socket, breaker panel must be rain-tight equipment. Meter socket jaws or clips shall be free of foreign material (mud, paint, plaster, etc.). **RINGLESS METER SOCKETS ARE NOT ACCEPTABLE.**
7. Meter box to be bolted to unistrut. Unistrut to be mounted to using through bolts. Pole shall be notched to the depth of the unistrut. Minimum 1/4" bolt diameter or box to unistrut & 1/2" minimum for unistrut to pole.
8. Neutral to be a continuous, unbroken conductor from the weatherhead to the neutral landing block.
9. Neutral landing block.
10. Install a bonding jumper or screw if the neutral landing block is insulated from the enclosure.
11. The ground wire (#4 bare, stranded or solid copper) shall be continuous from the neutral landing block to an approved grounding electrode system In compliance with NEC Article 250. The ground wire must be properly supported and attached to the pole at 24" intervals.
12. Approved grounding electrode system. 5/8" x 8' long ground rod and approved clamp. Entire length of rod shall be below grade.
13. Riveted non-ferrous metal address label. See Note 2 below and Paragraph 302.1 for label requirements.

**POLE REQUIREMENTS**

Only approved poles will be accepted. The pole must be fully commercially pressure treated and branded in accordance with APS specifications. A used or cut-off pole must be approved by a company representative. Minimum pole length is 18' with 4' set in the ground. Additional pole length will be required if the pole will be used by other utility companies. If a steel pole is used, refer to note 402.3.

**GENERAL NOTES:**

1. Meter location to be specified by Company Representative.
2. If more than one meter to the premises, each meter shall be permanently identified, by the Customer, to properly identify that portion of the premises being served. Metal stamping or metal tag is required. Painted identification is not acceptable.
3. All materials or work furnished by the Customer shall be in accordance with all applicable codes or standards.

4. Minimum service height above ground (phase to ground voltages):
  - a) Within Right-of-Way of roads, streets, alleys, non-residential driveways, parking lots, and other areas subject to truck traffic ..... 18'-0
  - b) Service over residential driveways. (See 401.0)..... 12'-6
  - c) Commercial spaces, driveways, and parking lots NOT subject to truck traffic ..... 12'-6
  - d) Areas accessible to pedestrians only..... 12'-0
5. Minimum attachment height is 12ft - 6in. Additional height may be required according to Authority having jurisdiction (AHJ).





**403.0 OVERHEAD SERVICE WIRE SIZES TABLE**

Permits and inspections are required. Please contact the governing inspection agency. This is a list of material for a normal typical overhead meter installation. All equipment shall comply with EUSERC requirements and all specifications found in the APS Electric Service Requirements Manual (ESRM). Wire size is braced on ampacity of the panel.

**RESIDENTIAL**

SERVICE RATING	COPPER	ALUMINUM	WEATHERHEAD & CONDUIT	NEUTRAL
100A	#4	#2	1-1/2"	Minimum size: 1 size smaller than phase conductor
125A	#2	#1/0	1-1/2"	
150A	#1	#2/0	1-1/2" (2" If #3/0)	
200A	#2/0	#4/0	2" (2-1/2" If > 4/0)	
225A	#3/0	#250	2" (2-1/2" If > 4/0)	

**COMMERCIAL**

SERVICE RATING	COPPER	ALUMINUM	WEATHERHEAD & CONDUIT	NEUTRAL
100A	#3	#1	1-1/2"	Minimum size: 1 size smaller than phase conductor
125A	#1	#2/0	1-1/2"	
150A	#1/0	#3/0	1-1/2" (2" If #3/0)	
200A	#3/0	#250	2" (2-1/2" If > 4/0)	
225A	#4/0	#300	2" (2-1/2" If > 4/0)	



APPLICATION

120/240 V 1Ø 3W  
 120/240 V 3Ø 4W  
 120/208 V 3Ø 4W  
 277/480 V 3Ø 4W

A.) BONDING BY CUSTOMER  
 SEE NOTE 2

B.) NEUTRAL LAY IN LUG

C.) TO MAIN SWITCH

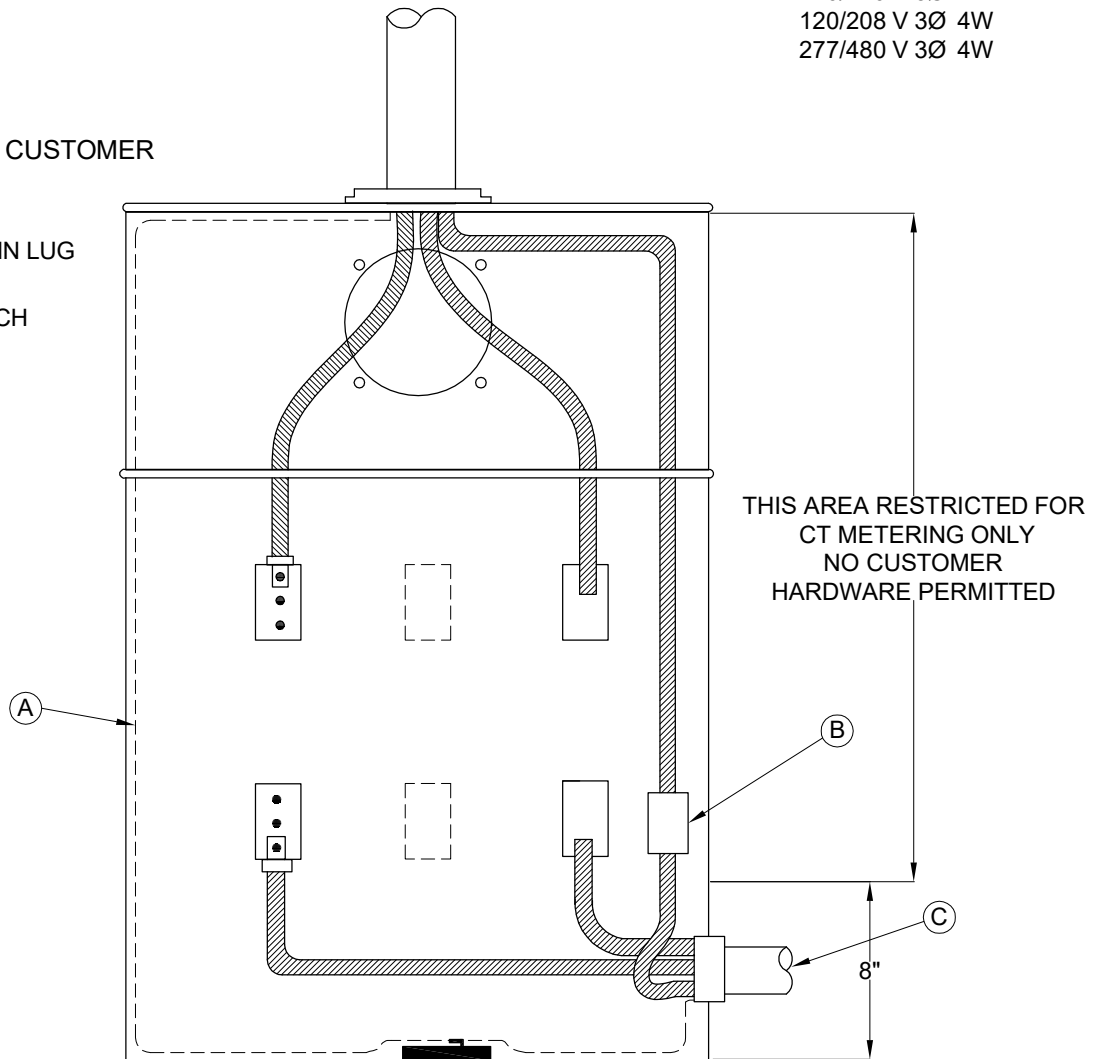

THIS AREA RESTRICTED FOR  
 CT METERING ONLY  
 NO CUSTOMER  
 HARDWARE PERMITTED

(1Ø 3W and Customer Wiring Shown)  
**400 AMP Overhead Service**

1. Wire and conduit sizes shall be per NEC.
2. When approved bond bushings are used, bond wire may be eliminated.
3. APS furnishes and installs CTs and test switch. The Customer installs the meter socket and runs customer neutral into meter panel.
4. When used for 3Ø-4W Delta service, high phase shall be on the right hand side and identified.