

UNDERGROUND SERVICE
Table of Contents - Section 500

PARAGRAPH		PAGE
500.0	GENERAL.....	1
500.1	UNDERGROUND SERVICES.....	1
500.2	TRENCHING.....	1
500.3	UNDERGROUND SERVICE PLANNING.....	1
500.4	PHOENIX NETWORK AREA.....	2
501.0	CUSTOMER-OWNED UNDERGROUND RISER REQUIREMENTS.....	3
501.1-1	RESIDENTIAL 1ø U.G. RISER SIZE.....	3
501.1-2	NON-RESIDENTIAL 1ø U.G. RISER SIZE.....	3
501.1-3	COMMERCIAL AND RESIDENTIAL THREE PHASE U.G. RISER SIZE.....	3
501.2	RISER MATERIAL.....	3
501.2-2	RISER COUPLINGS.....	3
501.3	RISER INSTALLATION.....	4
501.4	METALLIC RISER COATING.....	4
501.5	ATTACHMENT TO SES.....	5
501.6	RISERS FOR SERVICES INSTALLED IN CONDUIT	5
501.6-1	METALLIC RISER WITH SCH 80 PVC SWEEP (CONDUIT SYSTEM).....	6
501.6-2	METALLIC RISER WITH 45° SWEEP AND 45° PVC SWEEP (CONDUIT SYS.).....	6
501.6-3	METALLIC RISER WITH 90° SWEEP (CONDUIT SYSTEM)	7
501.6-4	SCHEDULE 80 PVC RISER WITH 90° SWEEP.....	7
501.6-5	SCHEDULE 80 PVC RISER W 45° SWEEP AND 45° PVC SWEEP	8
501.6-6	SCHEDULE 80 PVC RISER MARKINGS OR STICKER PLACMENT.....	8
502.0	SERVICE CONDUIT REQUIREMENTS.....	9
502.1	MATERIAL FOR SERVICE CONDUIT.....	9
502.2	STEEL CONDUIT.....	9
502.3	NON-METALLIC CONDUIT.....	9
502.4	MARKINGS ON PLASTIC CONDUIT	9
502.5	BENDS AND SWEEPS.....	9
502.5-1	MINIMUM RADIUS FOR SWEEPS.....	10
502.6	WORKMANSHIP (PVC).....	10
502.7	INSTALLATION OF NON-METALLIC CONDUIT.....	10
502.7-1	PVC TO PVC JOINTS	10
502.7-2	USE OF CORRECT PRIMERS AND CEMENTS.....	11
502.8	ENCASEMENT OF CONDUIT.....	11
502.9	USABILITY OF THE CONDUIT SYSTEM.....	12
502.10	CONNECTING TO EXISTING CONDUITS	12
502.11	SEPARATION FROM OTHER UG INSTALLATIONS (JOINT TRENCH).....	12
502.12-1	THE SERVICE CONDUIT SYSTEM (EXISTING TRANSFORMER).....	13
502.12-2	THE SERVICE CONDUIT SYSTEM (FROM A TRANSITION POLE)	14
502.12-3	THE SERVICE CONDUIT SYSTEM (CONDUIT STUB-OUTS)	15
502.12-4	TYPICAL CONDUIT STUB-OUT LOCATIONS (WITH RIGID STUB-OUTS).....	16
502.12-5	TYPICAL CONDUIT STUB-OUT LOCATIONS (WHEN FLEXIBLE STUB-OUTS ARE RQ).....	17



PARAGRAPH		PAGE
506.0	TYPICAL SERVICE ENTRANCE INSTALLATIONS (U.G.)	18
506.1	100 - 200 AMP 1 ϕ 3 WIRE (RESIDENTIAL).....	18
506.2	100 - 200 AMP 3 ϕ 4 WIRE (RESIDENTIAL).....	19
506.2-1	OBSOLETE METER INSTALLATION.....	20
506.3	OVERHEAD TO UNDERGROUND CONVERSION (MAXIMUM 200 AMP)	21
506.4	TEMPORARY FOR CONSTRUCTION METER POLE 1 ϕ 3 WIRE	22
506.5	TYPICAL TEMPORARY/PERMANENT SERVICE ENTRANCE (RESIDENTIAL).....	23
506.6-1.2	MOBILE HOME PEDESTAL 120/240, 1 ϕ 3 WIRE	24, 25
506.7-1.2	120 VOLT, 2 WIRE PEDESTAL.....	26, 27
506.8-1	COMMERCIAL METER PEDESTAL, 0-200 AMP 0-600 VOLT.....	28, 29
506.10	TYPICAL UNDERGROUND 400 AMP WALL-MOUNT CT/METER.....	30
506.11	S.E.S. UNDERGROUND - 400 THROUGH 800 AMPS.....	31
506.12	S.E.S. UNDERGROUND - 801 THROUGH 3000 AMPS.....	32
506.13	OPTIONAL TOP ENTRY SECTION FOR SES INSIDE BUILDING.....	33
506.14	TYPICAL SERVICE ENTRANCE SUPPORTS FOR U.G. SERVICE EQUIPMENT.....	34



500.0 GENERAL

500.1 UNDERGROUND

Underground services are installed in Customer provided conduit. See paragraphs 501 and 502 for U.G. Riser and Conduit Requirements. See Section 600 for Trenching Requirements. Consult with a Company Customer Service Representative for information regarding specifics to your situation.

500.2 TRENCHING

Remember to always call your local Blue Stake office for underground utility location at least two days before you dig. (See paragraph 100.12 Section 100) The phone number in the Phoenix Area is 602-263-1100. Outside of Phoenix please call your local APS office, phone numbers are listed in front of this manual on pages "B" and "C". See Trenching Requirements Section 600.

500.3 UNDERGROUND SERVICE PLANNING

In order to eliminate unnecessary delays, changes, etc., the Customer shall contact the Company at the initial planning stage so that the location of the service and meter can be determined. Company phone numbers are in front of this manual on pages "B" and "C".

THE COMPANY RESERVES THE RIGHT TO DETERMINE ALL METER AND UNDERGROUND SERVICE LOCATIONS AND ONLY AUTHORIZED PERSONNEL SHALL DETERMINE THE LOCATION

IN ALL CASES WHEN PROPOSING INSTALLATIONS OR ALTERATIONS WITHIN THE PHOENIX NETWORK AREA, CONTACT APS REGARDING THE TYPE OF SERVICE AVAILABLE, ETC. ALL VOLTAGES LISTED IN PARAGRAPHS 201.1 AND 201.2, SECTION 200 ARE AVAILABLE IN THIS AREA PLUS 277/480 VOLT NETWORK SERVICE. BY CONTACTING APS AND PROVIDING THE NECESSARY CUSTOMER DATA AT INITIAL PLANNING STAGES, SERVICE REQUIREMENTS, INCLUDING FAULT CONTRIBUTION DATA, WILL BE FURNISHED TO THE CUSTOMER

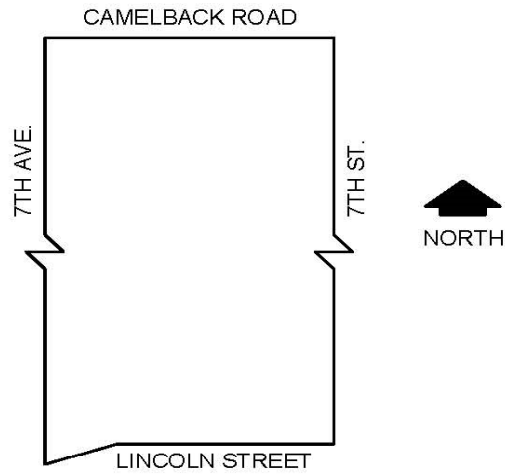

501.0 CUSTOMER – OWNED UNDERGROUND RISER REQUIREMENTS

501.1-1 RESIDENTIAL SINGLE PHASE U.G. RISER SIZE

<u>SES Rating</u>	<u>Min. Riser Trade Size</u>	<u>Min. Radius Size</u>
100 – 225A	2 1/2"	24"
226 - 400A	3"	24"
600A	2 - 3"	24"
800A	2 - 4"	24"

501.1-2 COMMERCIAL SINGLE PHASE U.G. RISER SIZE

<u>SES Rating</u>	<u>Min. Riser Trade Size</u>	<u>Min. Radius Size</u>
100 - 225A	2 1/2"	24"
* 226 - 400A	4"	24"
* 600A	2 - 4"	24"
* 800A	2 - 4"	24"

* Includes multi-meter packs for multi-family residential installations.

501.1-3 COMMERCIAL AND RESIDENTIAL THREE PHASE U.G. RISER SIZE

<u>SES Rating</u>	<u>Min. Riser Trade Size</u>	<u>Min. Radius Size</u>
100 - 225A	3"	24"
225 - 400A	4"	36"
600A	2 - 4"	36"
800A	2 - 4"	36"
1000A	2 - 4"	36"
1200A	3 - 4"	36"
1600A	4 - 4"	36"
2000A	* 5 - 4"	36"
2500A	* 7 - 4"	36"
3000A	* 9 - 4"	36"

* Dedicated Service Trench required for each S.E.S., separated by 10' center to center horizontally. No more than 9 conduits allowed in one trench.

NOTE: Outside diameter is approximately 1/2" larger than riser trade size.

501.2 RISER MATERIAL

Riser shall not be cut with a torch, welded or brazed. Underground risers shall be of Schedule 80 PVC, Rigid Metallic or Intermediate Metallic Conduit (IMC) and listed or rated for their intended use. **Only true round cross-section risers will be acceptable.**

NOTE: SCHEDULE 80 PVC RISERS CANNOT BE ENCLOSED. A RISER THAT IS ENCLOSED IN ANY MANNER, WHETHER PARTIALLY OR IN ITS ENTIRETY SHALL BE OF RIGID OR INTERMEDIATE METALLIC CONDUIT.

501.2-1 RISER COUPLINGS

No PVC riser couplings allowed above grade

* Dedicated Service Trench required for each S.E.S., separated by 10' center to center horizontally. No more than 9 conduits allowed in one trench.

** Exception to be reviewed on case by case basis by operations, Asset Management, and the Energy Delivery Compliance Committee.

501.3 RISER INSTALLATION

Risers shall be securely fastened to wall by at least one strap and the service equipment enclosure. The strap shall be located between the riser entrance to the service equipment and finished grade, plus or minus 6". Riser straps are not required if riser is 18" or less in length from ground to panel. The riser strap/straps shall be listed for the purpose for which it's intended. Plumbers tape or similar materials are unacceptable. The riser shall be plumb with no kicks or bends other than one sweep at the bottom for transition to trench elevation and securely fastened to wall with 1/4" lag screws or equivalent. Any deviation from plumb may result in the entire installation being turned down. (See Paragraphs 501.6-1, 2 and 3)

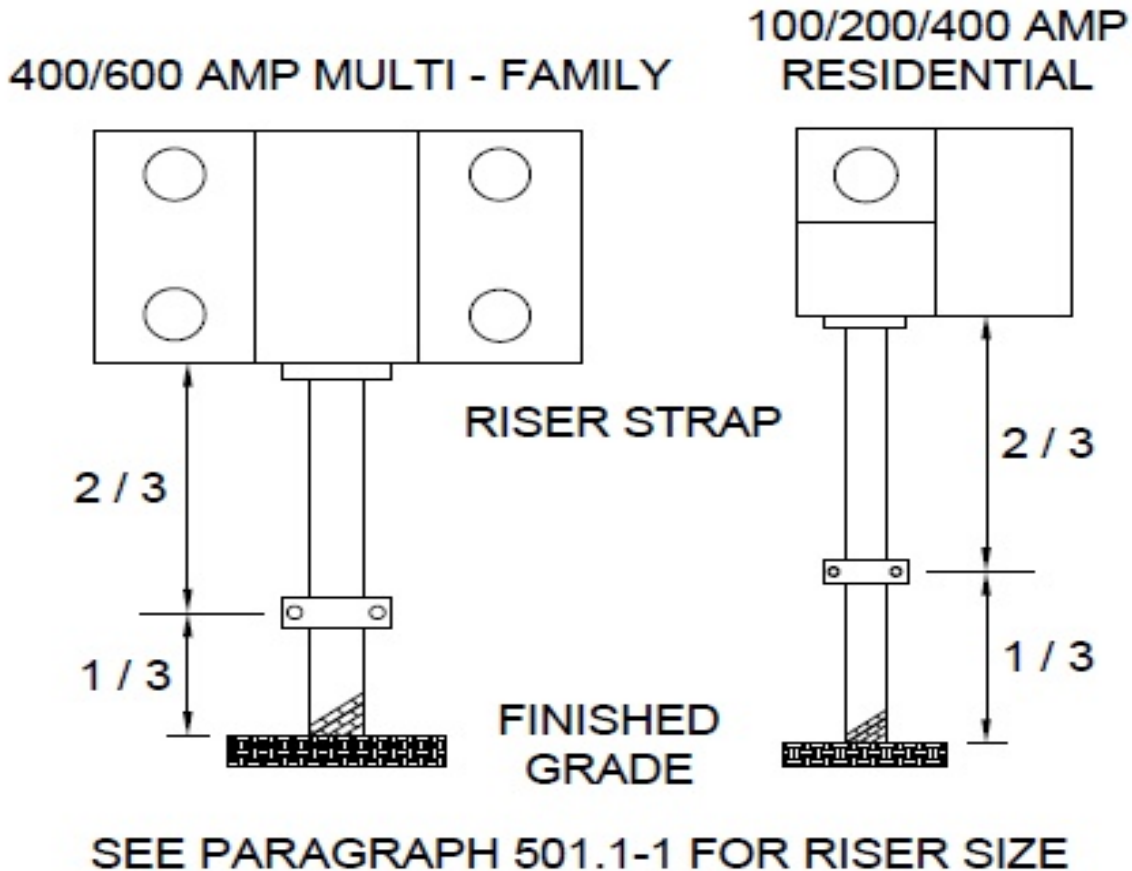

501.4 METALLIC RISER COATING

The portion of metallic risers below grade, up to a minimum of 6" above grade, shall be factory coated or shall be half-lapped with 20 mil. tape suitable for its use, to a total thickness of 40 mil. The tape shall be labeled to include the thickness (20 mil.) and the manufacturer's name. If riser is factory coated, it shall have a U.L. label.

Note: The coupler connecting the PVC conduit system to the metallic riser shall also be taped per the above paragraph.

501.5 ATTACHMENT TO SES

Schedule 80 PVC conduit risers shall be secured to the pull section with a threaded male slip-sleeve connector and a steel lock nut, a threaded male slip-sleeve connector into a factory bolt-on hub, or a malleable “chase nipple” into a threaded female slip-sleeve connector on the riser. (See Figure 1)

Metallic conduit risers shall be secured to the pull section using a riser “hub” with a bondable lock nut/bushing, a factory bolt-on hub, or a self-bonding hub (Meyers or equivalent). The self-bonding hubs shall be installed in the largest knock-out provided. (See Figure 2)

NOTES:

1. If factory bolt-on hub is used, all knock-outs shall be removed.
2. Reducer washers shall be installed on the inside and outside of section whenever the largest knock-out is not used.
3. A riser that is enclosed in any manner, whether partially or in its entirety shall be of rigid or intermediate metallic conduit.

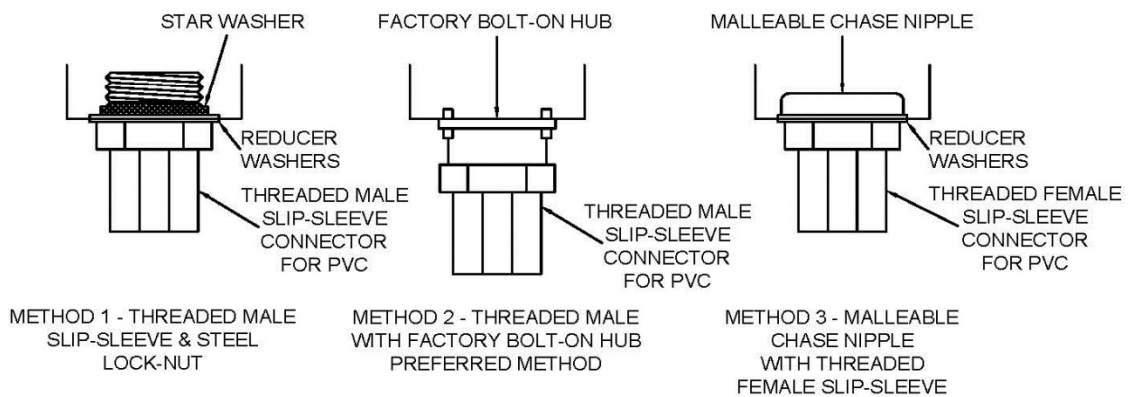

FIGURE 1 - APPROVED METHODS FOR PVC RISER ATTACHMENT

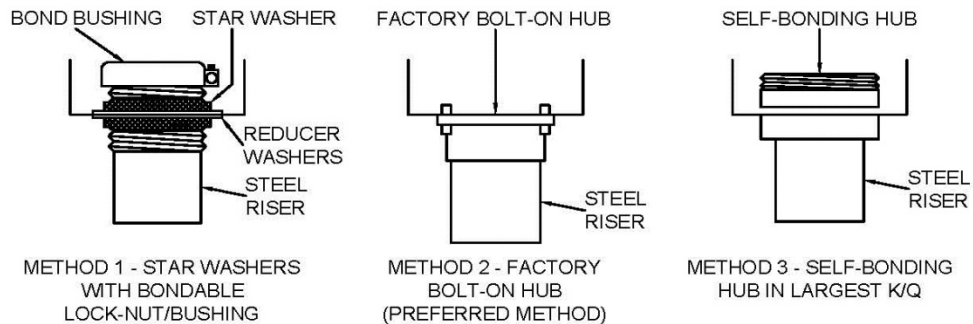

FIGURE 2 - APPROVED METODS FOR METALLIC RISER ATTACHMENT

501.6 RISERS FOR SERVICES INSTALLED IN CONDUIT

When service conduit is extended away from riser bend, there are three methods of making the vertical to horizontal transition. They are listed in order of preference. (See 501.6-1,2,3)

501.6-1 CUSTOMER – OWNED METALLIC RISER WITH SCH 80 RIGID PLASTIC 90° SWEEP

1. No portion of plastic sweep, including fittings, will be above grade.
2. A threaded steel to plastic fitting is installed at bottom of riser so that it will be below finished grade.
3. Where sweep runs horizontal, it shall have 24" minimum cover.
4. Sweep will have 24" radius as a minimum and shall be of SCH 80 grade rigid plastic conduit.
5. Metallic riser as required in Paragraph 501.2, 501.4, 502.5 and 502.5-1

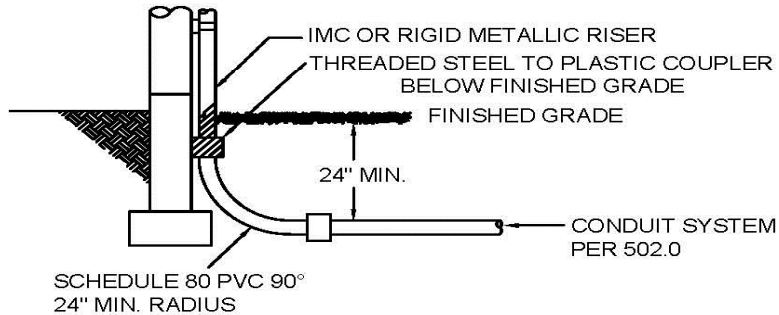

METALLIC RISER COUPLED TO SCH 80 PVC 90° BEND FOR CONDUIT SYSTEM

501.6-2 CUSTOMER - OWNED METALLIC RISER WITH 45° SWEEP AND SCHEDULE 40 RIGID PLASTIC 45° SWEEP

1. A threaded steel to plastic fitting to make transitions from steel riser to approved rigid plastic 45° sweep. (See Conduit Requirements, Paragraph 502.0) Metallic 45° sweep and plastic 45° sweep to be minimum 24" radius. Where sweep runs horizontal, there shall be a minimum of 24" of cover.
2. Metallic riser shall be as required in Paragraph 501.2, 501.4, 502.5 and 502.5-1

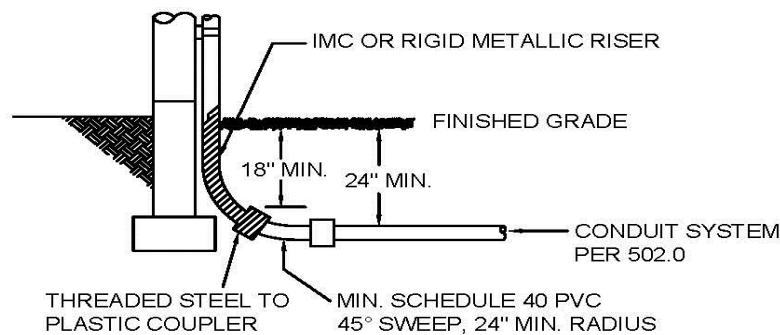

METALLIC RISER WITH 45° BEND COUPLED TO A PVC CONDUIT SYSTEM

501.6-3 CUSTOMER – OWNED METALLIC RISER WITH 90° SWEEP

1. A threaded steel to plastic fitting is installed at bottom of metallic sweep to make transitions from metallic to approved rigid plastic conduit (See Conduit Requirements, Paragraph 502.0) Where sweep runs horizontal, it shall have 24" minimum cover.
2. Metallic riser shall be as required in Paragraph 501.2, 501.4, 502.5 and 502.5-1

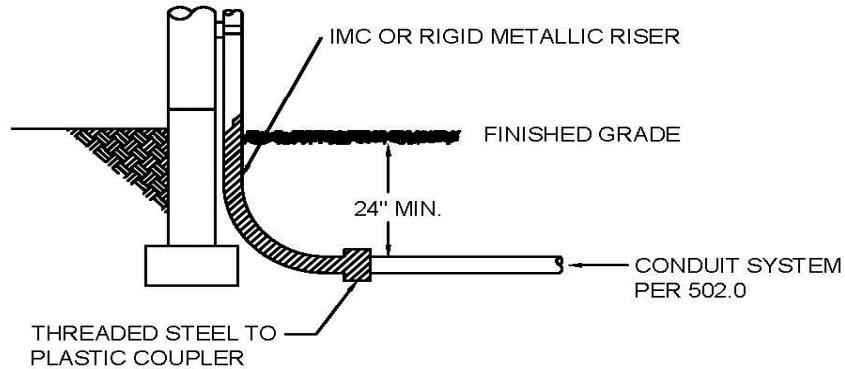

24" MIN. RADIUS, METALLIC RISER WITH 90° BEND COUPLED TO A PVC CONDUIT SYSTEM (SEE PARAGRAPH 502.5 AND 502.5-1)

501.6-4 CUSTOMER – OWNED SCHEDULE 80 PVC RISERS WITH 90° SWEEP

1. A riser that is enclosed in any manner, whether partially or in it's entirely shall be of rigid or intermediate metallic conduit.
2. No PVC couplings allowed above grade
3. See paragraph 501.6-6 and 502.4

NOTE: Schedule 80 PVC markings on conduit riser shall remain visible for inspection purposes.

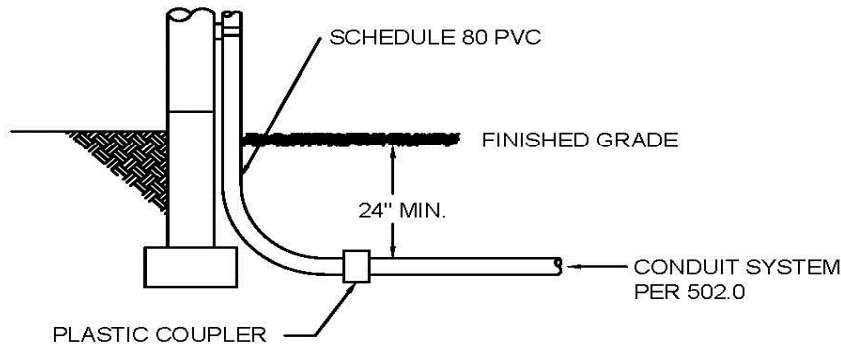

24" MIN. RADIUS, SCHEDULE 80 PVC WITH 90° BEND COUPLED TO A PVC CONDUIT SYSTEM (SEE PARAGRAPH 502.5 AND 502.5-1)

501.6-5 CUSTOMER – OWNED SCHEDULE 80 PVC RISER WITH 45° SWEEP AND SCHEDULE 40 RIGID PLASTIC 45° SWEEP

1. A riser that is enclosed in any manner, whether partially or in it's entirely shall be of rigid or intermediate metallic conduit.
2. No PVC couplings allowed above grade
3. See paragraph 501.6-6 and 502.4

NOTE: Schedule 80 PVC markings on conduit riser shall remain visible for inspection purposes

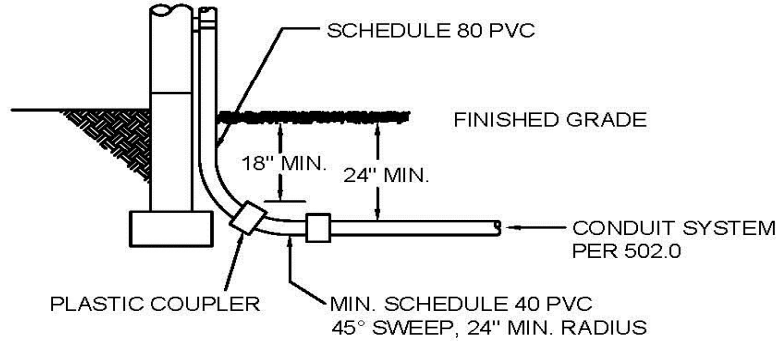

24" MIN. RADIUS, SCHEDULE 80 PVC WITH 45° BEND COUPLED TO A PVC CONDUIT SYSTEM (SEE PARAGRAPH 502.5 AND 502.5-1)

501.6-6 SCHEDULE 80 PVC MANUFACTURER RISER MARKINGS OR STICKER PLACEMENT

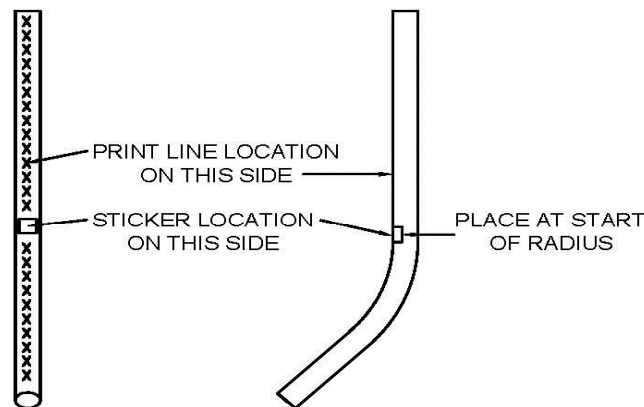

1. THE PRINT LINE OR STICKER PLACEMENT FOR A SCH 80, 24" R X 45° PVC RISER SHALL BE AS SHOWN. THIS WILL FACILITATE INSPECTION OF THE RISER AFTER INSTALLATION.

502.0 SERVICE CONDUIT REQUIREMENTS

502.1 MATERIAL FOR SERVICE CONDUIT

Material for service conduit shall be listed as electrical conduit. Acceptable material shall be PVC rigid conduit and when specified, IMC or Rigid metallic conduit taped or coated per 501.4 for direct burial.

502.2 STEEL CONDUIT

All rigid or intermediate conduits and fittings shall be hot-dipped galvanized. Rigid or Intermediate steel conduit shall be installed with threaded couplings and joints made up tight. (See Paragraph 501.4 for taping and coating requirements) **Conduit shall not be cut with a torch, welded or brazed.**

502.3 NON-METALLIC CONDUIT

Non-metallic conduit shall meet the following material and marking requirements for each application by product material used or as specified on the construction or composite drawing.

**TABLE 502.3
APPROVED SERVICE CONDUIT FOR CUSTOMERS INSTALLATION**

APPLICATION	ACCEPTABLE PRODUCT MATERIAL	CONDUIT MARKING REQUIREMENTS
Straight Conduit PVC DB-120 (See Notes 1 & 2)	PVC DB-120 (Modulus 400,000 PSI)	Mfg. name, nom. size, 90°C, Type (i.e. DB120), ASTM F-512, PVC 12254
	PVC SCH 40 or SCH 80	Mfg. name, nom. size, PVC, SCH 40 mx SCH 80, NEMA TC-2
Bends, Sweeps and Elbows (See Note 3)	PVC SCH 40 or SCH 80 (See Note 4)	Mfg. name, nom. size, PVC, SCH 40 mx SCH 80, NEMA TC-2 radius, degree of curvature
Fittings	PVC SCH 40 or SCH 80	Mfg. name, nom. size, PVC, SCH 40 mx SCH 80, NEMA TC-2 (marking may be on packaging material)

NOTES:

1. 12254B minimum cell classification per ASTM D-1784.
2. PVC DB-100, modulus 400,000 PSI, ASTM F-512 is suitable for 4" and 5" diameters.
3. 4" diameter & under - SCH 40 NEMA TC-2; 5" diameter & larger - SCH 80 NEMA TC-2, 60" radius.
4. Sweeps at house end may be required to be SCH 80. (See Paragraph 501.6-1)
5. All PVC shall be gray.

502.4 MARKINGS ON PLASTIC CONDUIT

Each length of plastic conduit shall be marked at least every 5'. Each bend shall also be marked. All markings must include the items required in Table 502.3, above.

502.5 BENDS AND SWEEPS

METALLIC - One shot bending. Specified radius maintained. Internal diameter of conduit not effectively reduced. Factory bent sweeps are preferred; however, field bent sweeps are acceptable if done properly.

NON-METALLIC - Factory bent sweeps shall be used.



502.5-1 MINIMUM BENDING RADIUS FOR SWEEPS IN A CONDUIT SYSTEM

All sweeps in a conduit system to be a minimum of 24" radius, "unless otherwise specified." All sweeps in a 4" conduit system designed for 3Ø to be a minimum of 36" radius, "unless otherwise specified." All non-metallic sweeps to be Schedule 40 minimum except as specified in Paragraph 501.6-1.

502.6 WORKMANSHIP (PVC)

Conduit shall be cut cleanly and square. All burrs and sharp edges which may damage conductors shall be removed before joining. PVC joints shall be primed before gluing. Gluing solvent shall be applied to both pieces to be joined. The conduit system shall be clean of internal obstructions and contaminants which may interfere with pulling of the conductors, the life of the conductors or conduit system. Installed conduit shall not be left uncapped.

502.7 INSTALLATION OF NON-METALLIC CONDUIT

a) **Conduit transitions from Schedule 40 or Schedule 80 to DB conduit shall be chamfered.** All conduit and fittings not chamfered by the manufacturer shall be chamfered in the field with a knife, half-round file or abrasive open mesh cloth, to provide a smooth transition which will not cause scuffing of the cable when it is pulled through the conduit during installation.

b) Wipe dirt and foreign material from conduit and fitting with a clean, dry cloth.

502.7-1 PVC TO PVC JOINTS

Apply purple primer/cleaner ASTM F 656, to both the fitting socket and the conduit. Avoid puddling of the primer. Verify all surfaces to be joined are covered. This primer coat is important, as it helps to penetrate the hard inner surfaces on most bell-end conduit and on fittings which are fabricated from conduit stock. Many of the extruded conduit stocks and some molded fittings have hard inner surfaces, and are more difficult for the cement to penetrate without aid from the primer.

Apply a coat of gray PVC to PVC cement ASTM D 2564, to both parts of the joint, and immediately push the joint together with a slight rotating motion (in one direction only). When the joint bottoms out, hold without motion for 15 seconds (1 minute in extreme cold weather), so that conduit does not push out of the fittings. Do not twist or drive conduit after insertion is complete.

NOTE: The requirement for the purple color on the primer and the gray color on the PVC cement is to aid in the inspection of finished work. Use of clear cement makes for poor inspection, performance and failure to use primer with any PVC system results in a joint that is almost guaranteed to fail.

BRUSH / APPLICATOR

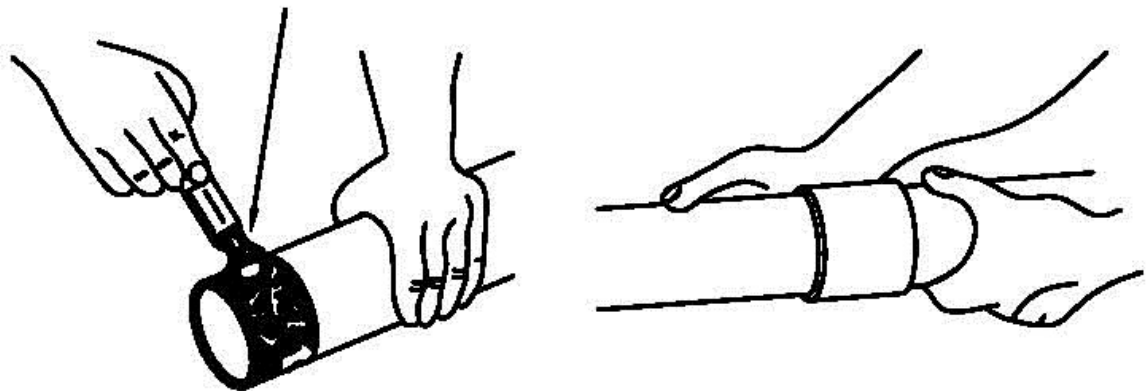

502.7-2 USE OF PRIMERS OR CEMENTS, OTHER THAN THE ONES LISTED ABOVE, WILL RESULT IN UNACCEPTABLE JOINTS

A natural bristle brush or the applicator supplied with the cement container shall be used. Plastic bristle brushes shall not be used as the primer and cement will dissolve the bristles. Follow the manufacturer's instructions on the primer and cement containers. Do not use any cement which shows signs of thickening. Shelf life on the unopened container is 3 years from the date of manufacture stamped on the container.

502.8 ENCASEMENT OF CONDUIT

Where service conduits must be installed under a building, the conduits shall be concrete encased (3000 psi at 28 days) and the top of the encasement shall have a minimum of **24 inches** clear separation below the structure foundation. **A minimum of 2 inches vertical and horizontal separation is required between concrete-encased conduits.** (See Figure 1) **Sidewalls and bottom of trench shall provide a minimum of 2 inches separation from conduit.** (See Figure 1 and 2) **The top of concrete encasement to be a minimum of 3 inches from top of conduit.** Sweeps are to be concrete encased also with a minimum of 2 inches of concrete; however, the minimum separations between conduits do not apply at service entrance or transformer pads. (See Figure 3) All concrete encased conduits require the use of spacers to insure conduit does not move during pouring of concrete. (See Figure 3 for maximum distance between spacers.) All conduits encased in concrete shall be mandrelled.

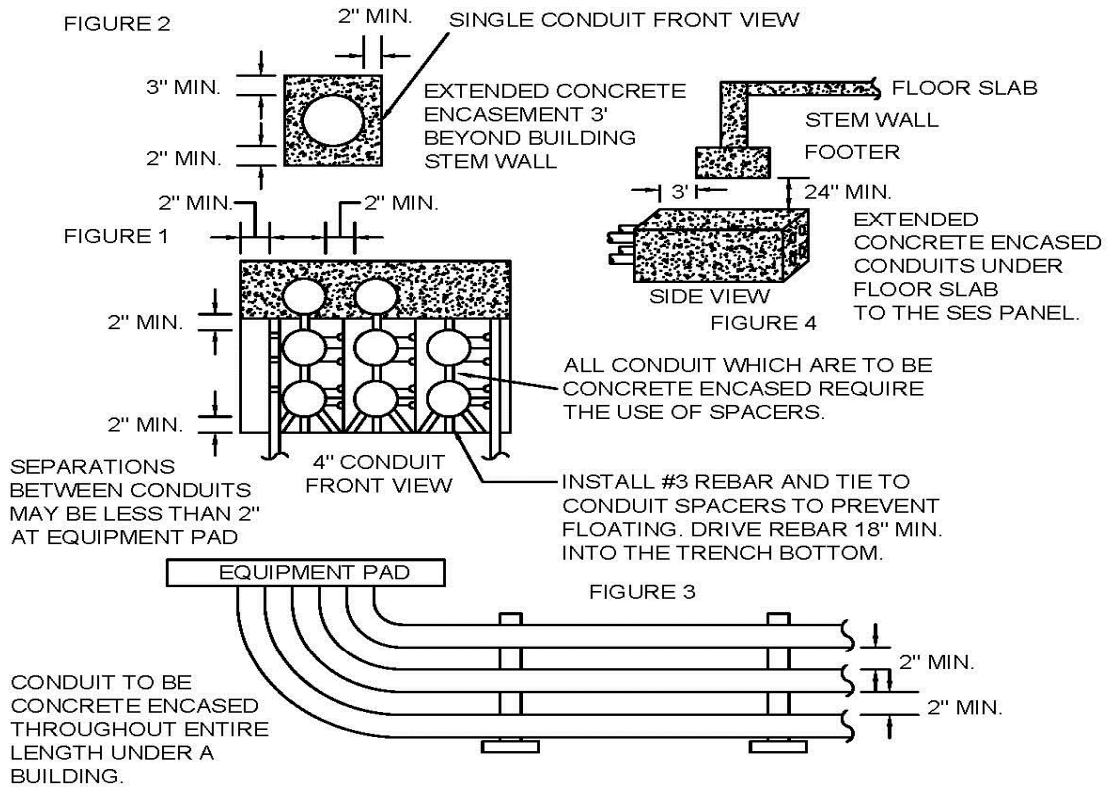

502.9 USABILITY OF CONDUIT SYSTEMS

Extreme care shall be exercised to ensure that concrete and other foreign matter does not enter the conduit being laid, while encasing, or at any time thereafter. All conduit shall be free of obstruction, dirt, rock, etc. **The conduit systems shall be clean useable systems at the time APS installs conductors.** In all cases the customer is responsible for the usability of the conduit systems at the time APS install conductors.

502.10 CONNECTING TO EXISTING CONDUITS

Empty conduits which have been stubbed out by APS for future attachments to Customers may be located and exposed by the Customer performing the attachment. (See 502.12-3, 4, and 5)

Contact an APS Customer Service Representative for the approximate location of service conduit stub-outs on your property.

502.11 SEPARATION FROM OTHER UNDERGROUND INSTALLATIONS

In order to permit access to and maintenance of either facility without damage to the other, a 24 inch horizontal separation shall be maintained between APS Electric Facilities and water, sewer or gas pipeline systems. A minimum 60 inch clear horizontal separation is required between cable installed in conduit and the outside wall of the pool or its auxiliary equipment.

APS Facilities shall not be installed beneath cool decking.

Exception: Natural gas facilities shall be permitted to be "Joint-Trench" with APS facilities. Provided all requirements of Section 600 are met.

In the event of an inconsistency or conflict with any Municipal specifications, the more stringent specification shall apply. Check your local city or country codes for possible greater separation requirements.

502.12-1 THE SERVICE CONDUIT SYSTEMS (EXISTING TRANSFORMER OR J-BOX)

DESIGN GUIDELINES:

Each single-phase service conduit systems, from the bottom of service equipment enclosure to source of service as designated by APS, shall meet the following requirements unless otherwise directed by APS.

- A) Conduit to be same trade size as approved single-phase riser (SEE 501.1-1 and 501.1-2).
- B) Total run shall not exceed 150ft. total length or more than 270° of bends including 90° sweep at riser bottom. 90° sweep at transformer is not included in 270° total.
- C) A service conduit system in excess of that described in "B" may require larger radius bends and/ or concrete encased sweeps. APS Division Engineering should be consulted in these instances.
- D) **The conduit shall have as a minimum, 24" of cover to finished grade from top of conduit.**

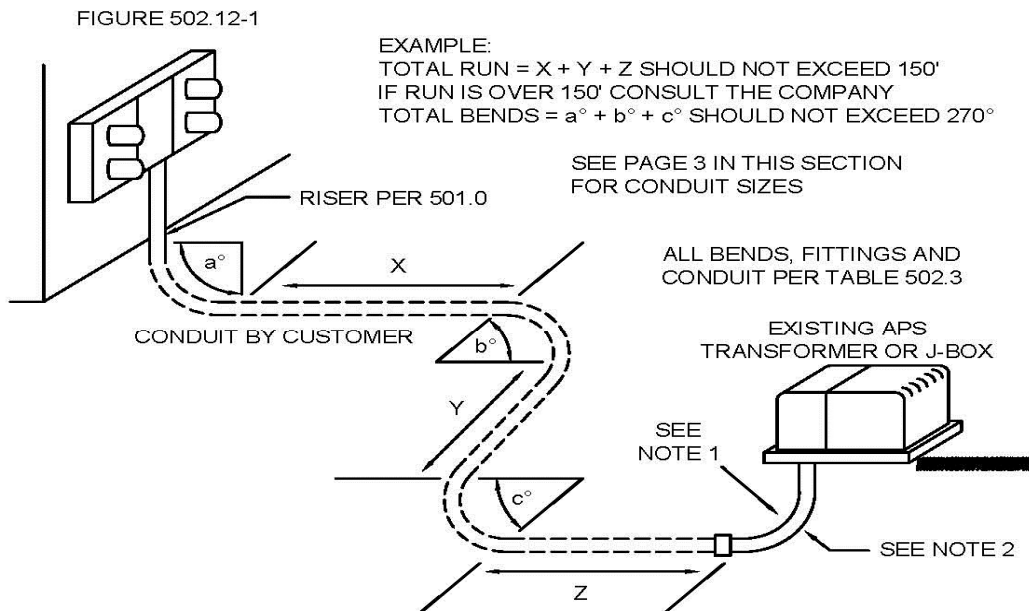

NOTES:

1. Customers to install conduit from service entrance equipment to transformer pad or j-box. Conduit to be capped. Customers to provide 36"x36"x depth of facilities "bell hole" per 502-12-5
2. APS to install Customer provided sweep into energized source.
3. Customer to supply, own and maintain the UG riser. For conduit installation procedure, See Section 502.0
4. **This drawing shows existing transformer with no future stub-outs installed. For existing transformers with stub-outs, See Paragraph 502-12-3 and 502-12-5.**
5. Customers to follow Blue Stake requirements.

502.12-2 THE SERVICE CONDUIT SYSTEMS (FROM TRANSITION POLE) SINGLE PHASE

DESIGN GUIDELINES:

Each single-phase service conduit systems, from the bottom of service equipment enclosure to source of service as designated by APS, shall meet the following requirements unless otherwise directed by APS.

- A) Conduit to be same trade size as approved single-phase riser (SEE 501.1-1 and 501.1-2).
- B) Total run shall not exceed 150ft. total length or more than 270° of bends including 90° sweep at riser bottom. 90° sweep at pole is not included in 270° total.
- C) A service conduit system in excess of that described in "B" may require larger radius bends and/ or steel sweeps. APS Division Engineering should be consulted in these instances.
- D) **The conduit shall have as a minimum, 24" of cover to finished grade from top of conduit.** If crossing a street or right of way, check with APS Division Engineering for minimum depth requirements.

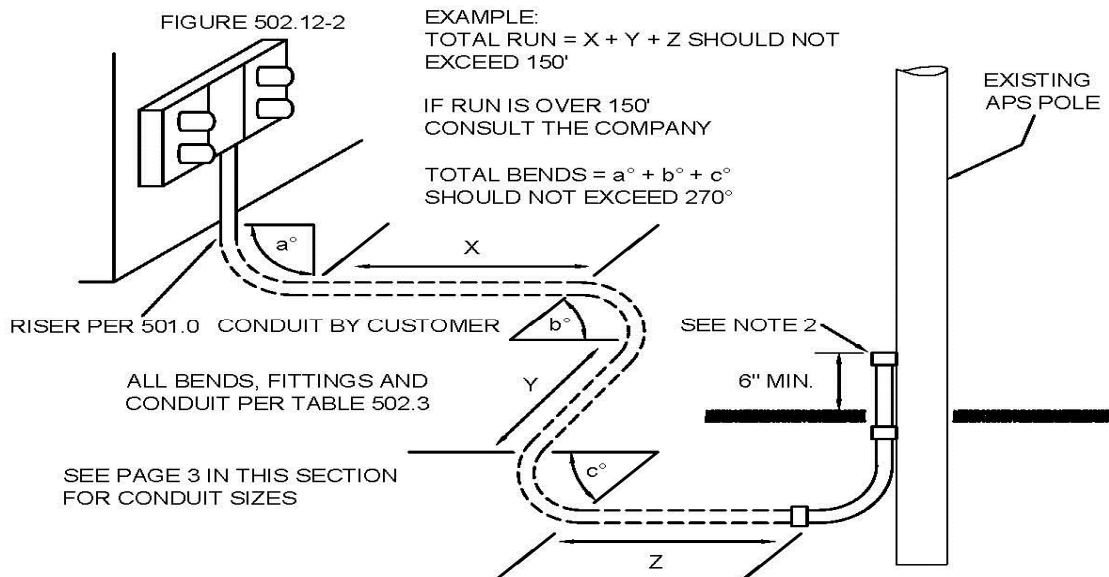

NOTES:

1. Customers shall contact a qualified APS representative prior to trenching to determine the trench alignment and location of the transition sweep at the pole.
2. Customers to install conduit from service entrance to base of APS pole and install approved sweep at pole location. Conduit to be extended a minimum of 6" above finished grade and capped.
3. Customers to follow Blue Stake requirements
4. For conduit installation procedure, See Paragraph 502.0
5. UG riser supplied, owned and maintained by customer.

502.12-3 THE SERVICE CONDUIT SYSTEM - (CONDUIT STUB-OUTS) SINGLE PHASE

- a) Customer to contact an APS Customer Service Representative for the approx. location of conduit stub-out on property then, Customer to locate and expose end of existing conduit stub-out from transformer. See drawing on next page for typical location of stub-out.
- b) Customer to supply, own and maintain UG conduit riser
- c) Customer to install conduit from service entrance to exposed stub-out.
- d) Customer to join existing stub-out and conduit from service entrance. Make certain no debris enters conduit. (See Paragraph 502.9)
- e) See Paragraph 502.12-1 & 2 for maximum number of bends in conduit run. (Check with your Customer Service Representative for number of bends in existing stub-outs. Maximum number of bends includes bends in stub-out conduit.)
- f) APS to install service conductors

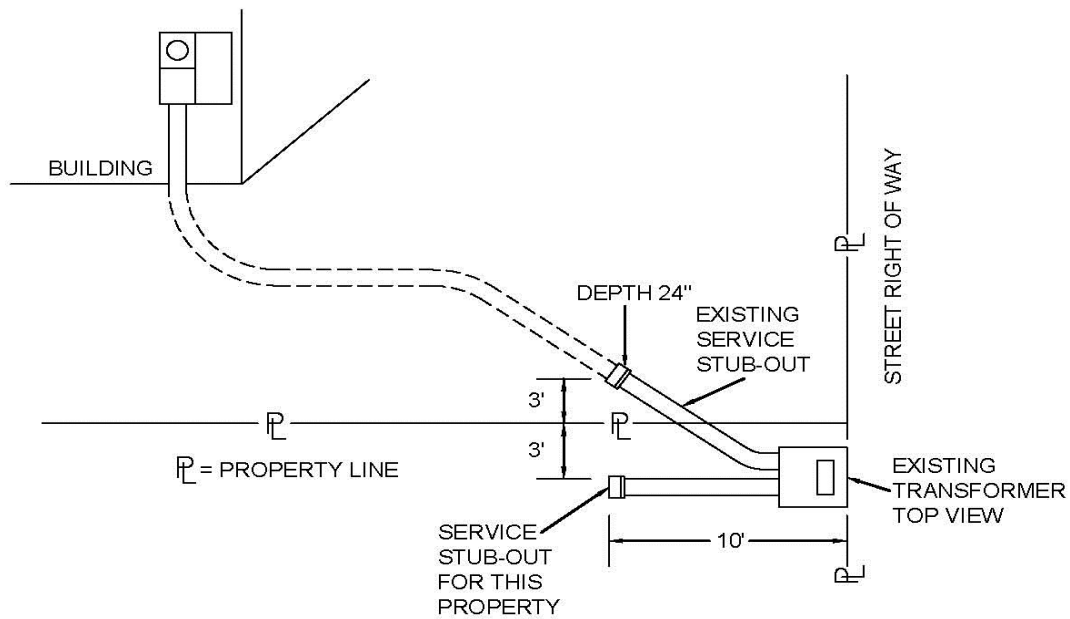

THE SERVICE CONDUIT SYSTEM - SINGLE PHASE
TYPICAL CONDUIT STUB-OUT LOCATIONS FOR USE WITH RIGID STUB-OUTS:

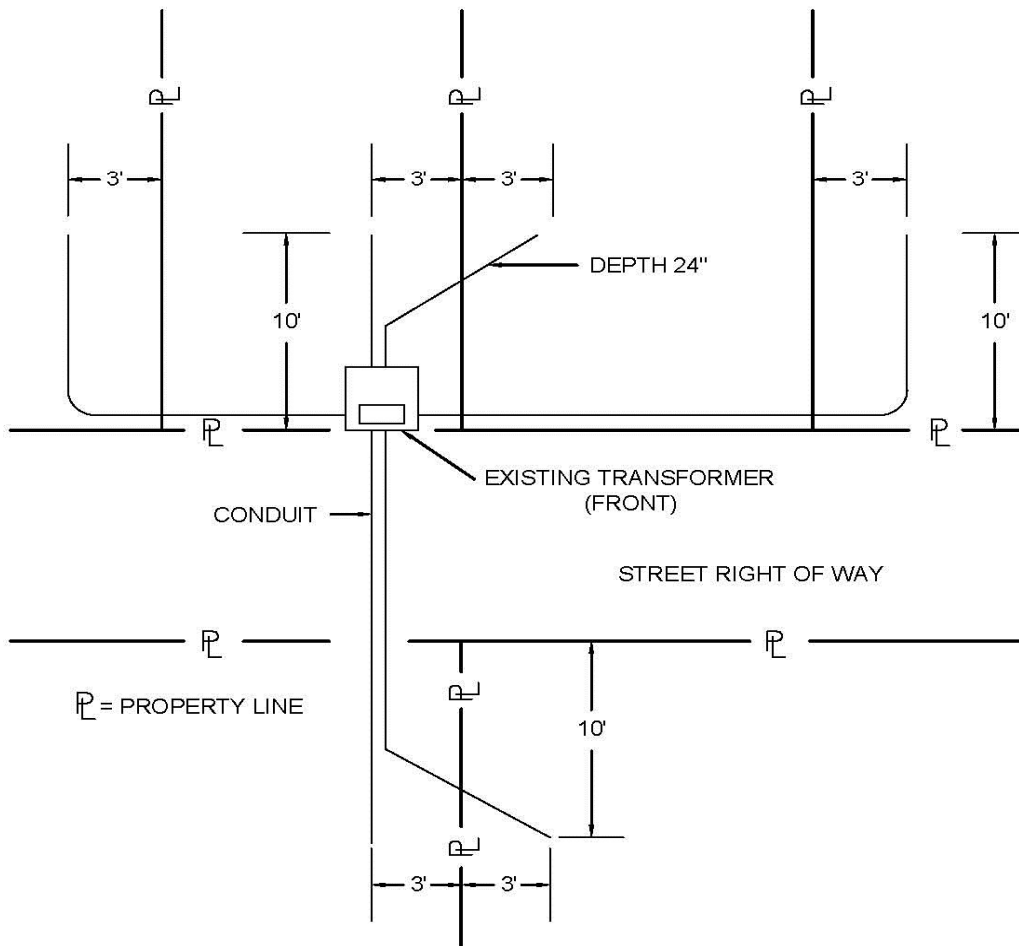

CHECK WITH APS CUSTOMER SERVICE REPRESENTATIVE FOR THE APPROX. LOCATION OF CONDUIT STUB-OUTS ON YOUR PROPERTY

**THE SERVICE CONDUIT SYSTEM - SINGLE PHASE
TYPICAL SECONDARY CONDUIT ENTRY FOR EXISTING
TRANSFORMERS AND J-BOXES:**

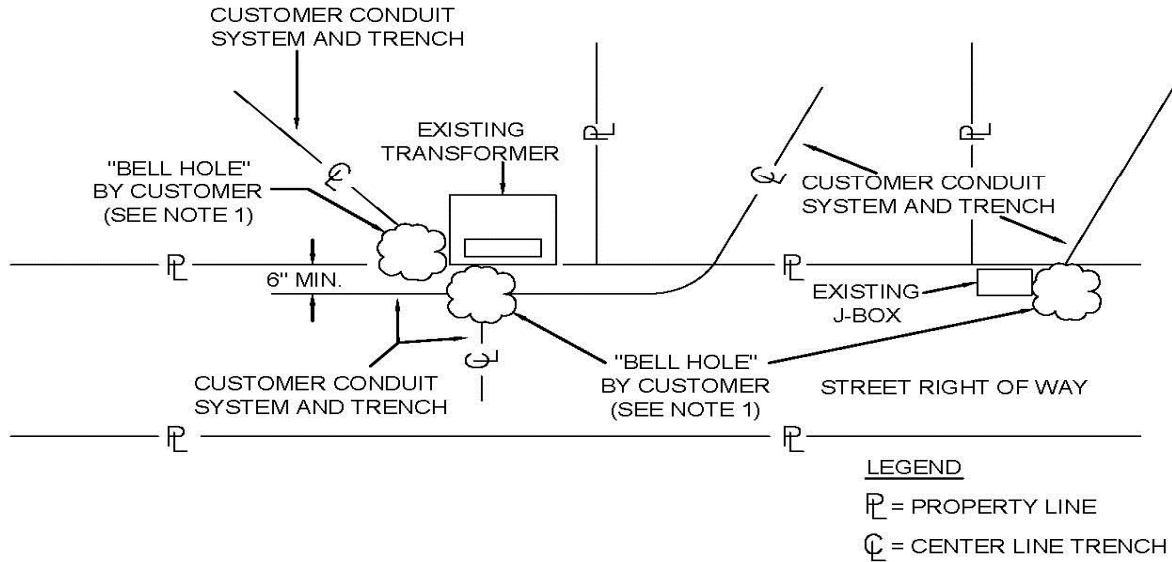

CHECK WITH APS CUSTOMER SERVICE REPRESENTATIVE FOR THE APPROX. LOCATION OF CONDUIT STUB-OUTS ON YOUR PROPERTY

NOTE:

1. "Bell Hole" shall be dug by Customer to a location designated by APS Representative at transformer or J-Box, with minimum dimensions of 36" x 36" x depth of facilities being installed

506.0 TYPICAL SERVICE ENTRANCE INSTALLATION (U.G.)

506.1 100 AMP – 400 AMP SINGLE PHASE THREE WIRE (RESIDENTIAL)

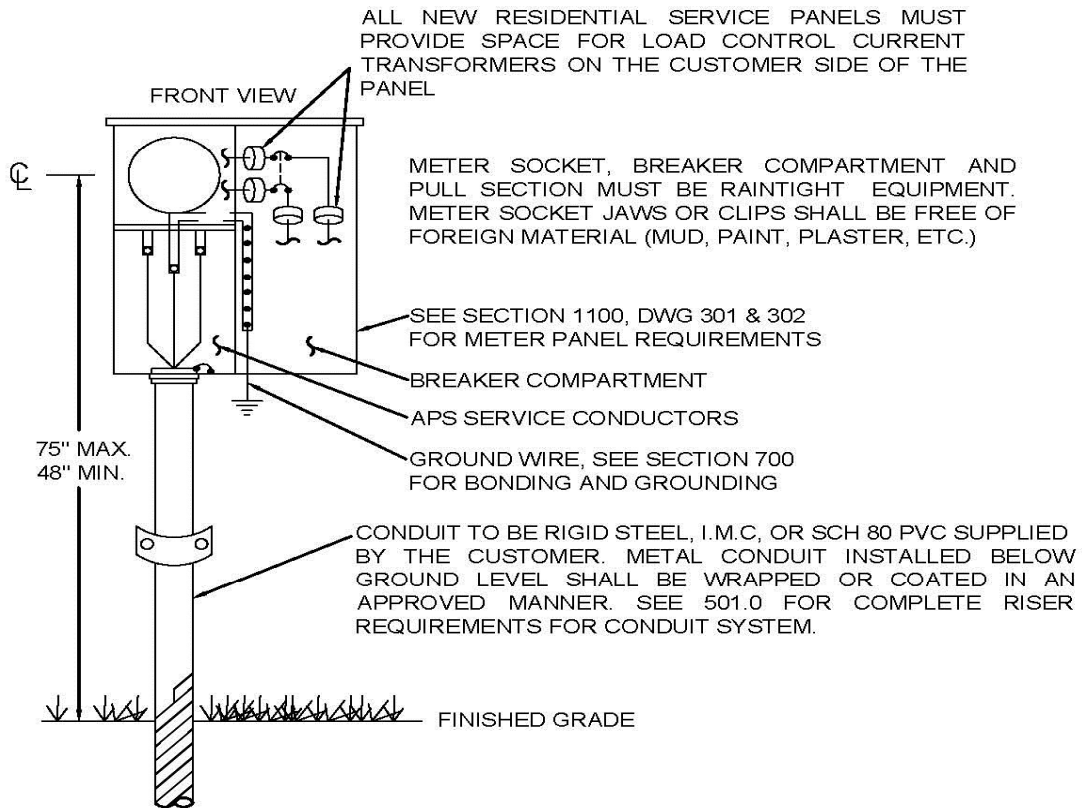

NOTES:

1. See section 1100 DWG 301 & 302 for residential meter panel requirements
2. Underground service conductors and connections to service terminals provided by APS
3. UG Riser is supplied, owned and maintained by the customer.
4. This is the preferred installation for single family residential applications.

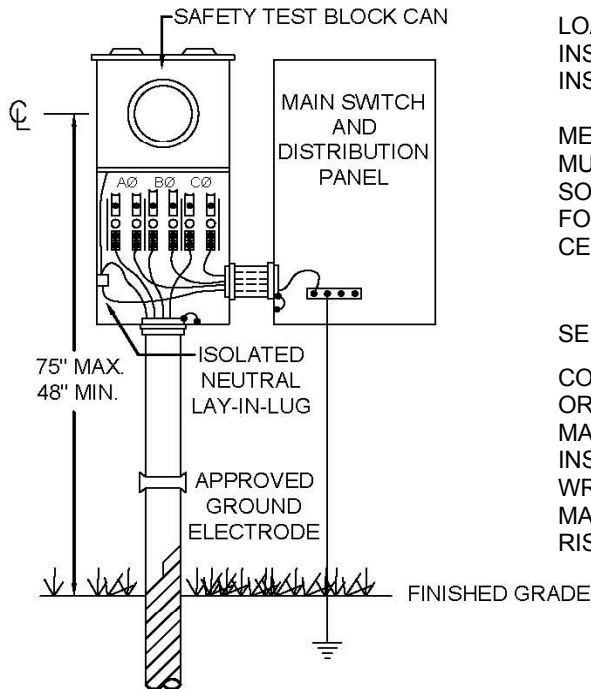

LOAD CONTROL CURRENT TRANSFORMERS TO BE INSTALLED IN DISTRIBUTION PANEL, NOT TO BE INSTALLED IN METER PANEL.

METER SOCKET AND BREAKER COMPARTMENT MUST BE WEATHER-PROOF EQUIPMENT. METER SOCKET JAWS OR CLIPS SHALL BE FREE OF FOREIGN MATERIAL.. (MUD, PAINT, PLASTER, CEMENT, ETC.)

SEE SECTION 700 FOR BONDING AND GROUNDING CONDUIT TO BE 3" MINIMUM RIGID STEEL, I.M.C., OR SCH 80 PVC AND IS SUPPLIED, OWNED AND MAINTAINED BY THE CUSTOMER METAL CONDUIT INSTALLED BELOW GROUND LEVEL SHALL BE WRAPPED OR COATED IN AN APPPROVED MANNER. SEE PARAGRAPH 501.0 FOR COMPLETE RISER REQUIPMENT FOR CONDUIT SYSTEM.

NOTES:

1. Neutral conductor from customer's distribution panel shall be code sized and shall extend into meter cabinet 18" for connection by APS. APS shall supply compression connector and make up neutral in the meter cabinet.
2. Underground service conductors are provided by APS.
3. See Section 502.0 for conduit requirements.
4. All wire and equipment shall comply with the National Electric Code.
5. For a 3Ø 4wire Delta service, the power phase (high leg) must be installed in the right hand (CØ) test block and meter socket position and identified by an outer finish that is orange in color. See Section 300, Paragraph 303.7.

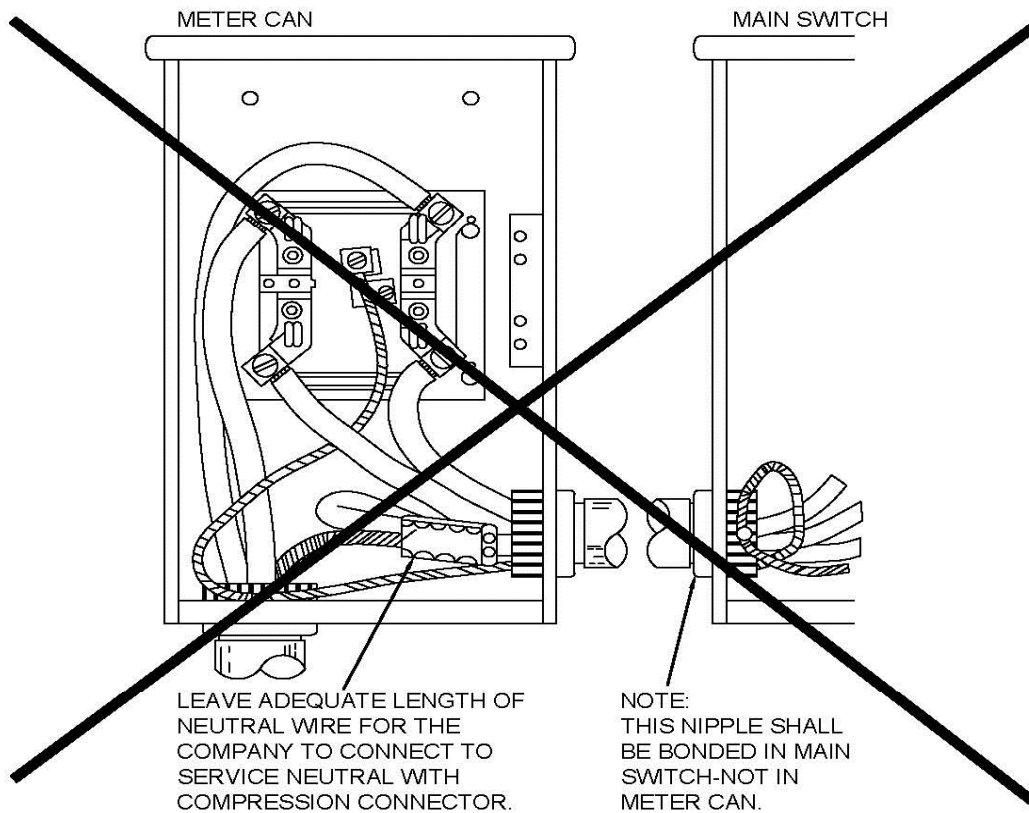

U.L. APPROVED BONDING HUBS MAY BE USED IN LIEU OF BONDING BUSHINGS.

OBSOLETE: FOR MAINTENANCE ONLY

See Paragraph 506.1 and 506.2

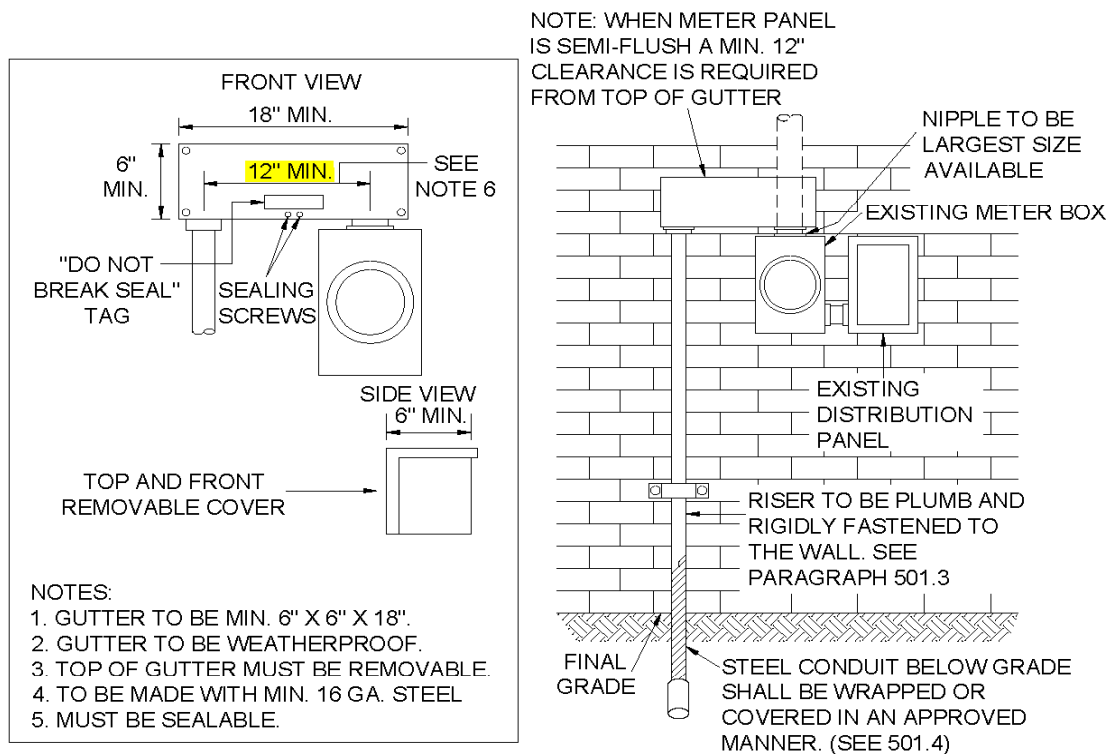

NOTES:

1. The Customers shall be responsible for the revamping of the service entrance from overhead to underground, as shown on this drawing.
2. Customer supplies, owns and maintains the UG riser. See 501.0 for riser requirements.
3. All wiring and equipment shall comply with the NEC
4. Riser, gutter and OH nipple shall be bonded and include bushing for cable protection.
5. NOT TO BE USED ON NEW INSTALLATIONS.
6. Gutter may be a special order item. See your electrical supplier.
7. Due to the complexities of these installations, each installation shall be treated on a case by case basis, and shall be approved by the APS Meter Shop.

TEMPORARY FOR CONSTRUCTION - SERVICE AND METER POLE,
SINGLE PHASE THREE WIRE, 120/240 VOLT

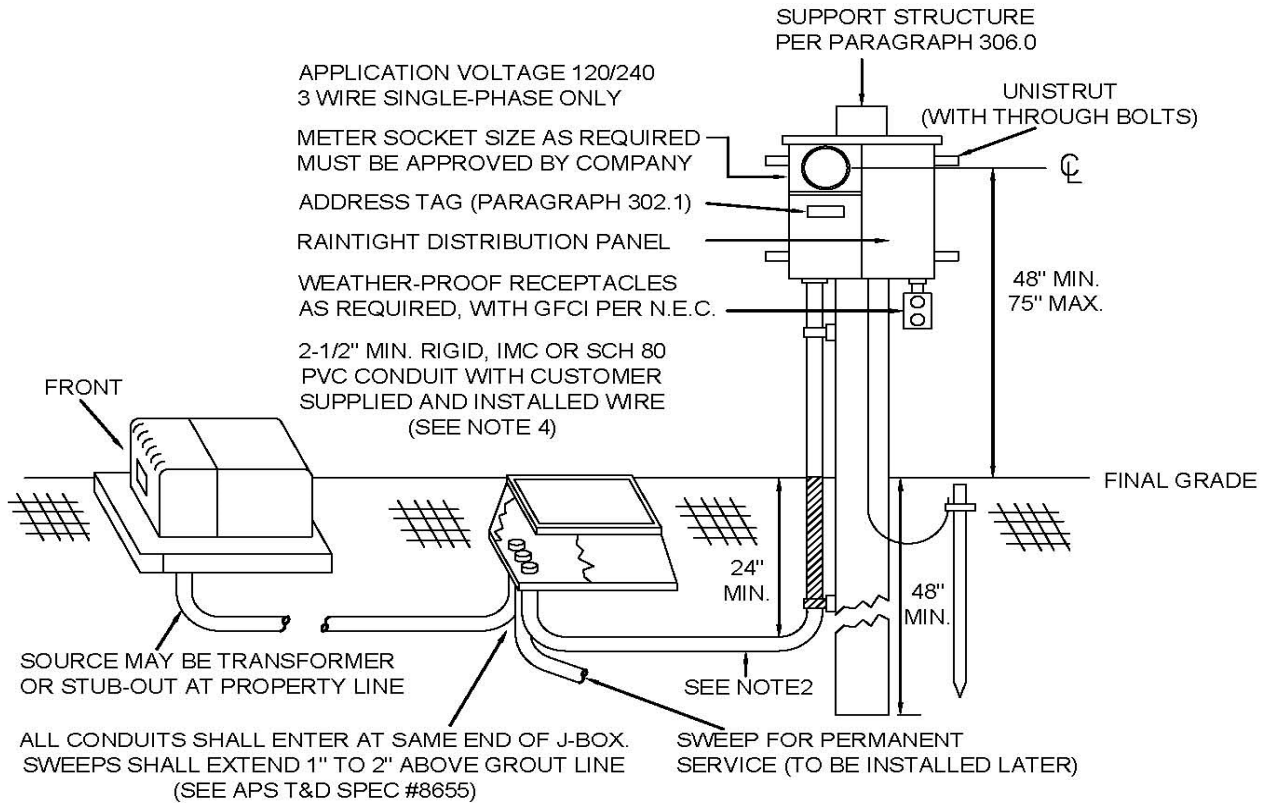

NOTES:

1. APS to determine which transformer or junction box shall feed service pole
2. Approved service wires in conduit shall be installed by Customer and extended to a point designated by APS. **A sufficient coil of wire to reach the secondary terminals of the transformer must be left. APS to terminate service in transformer.** If conduit stub-out from source is not available, see 502.12-5

Exception: Temporary services of 200 amps or less, located 10 feet or less from the junction box or transformer, may use approved direct-buried wire instead of conduit.
3. All wires and equipment shall be per N.E.C. and local codes. See section 400, Paragraph 402.2 for recommended pole material requirements, See Section 500, Paragraph 506.6-1 for alternative installations. See Section 100 for definition of "temporary"
4. **If temporary pole cannot be set within 10 feet of a junction box or transformer, all conduit sizes shall be per 501.1-2 and must meet all permanent installation requirements. Customer to supply, own and maintain the UG riser. (APS will install wire from meter to junction box or transformer.)**

CAUTION:

Before setting pole and driving ground rod be sure to notify Blue Stake. See Section 100, Paragraph 100.12 for phone Number.

506.5

TYPICAL TEMPORARY/PERMANENT SERVICE ENTRANCE (RESIDENTIAL)

1. Customer shall obtain permit for temporary service for this type of installation from local Inspection Agency before installing the equipment. **May not be available in all jurisdictions.**
2. Customers shall install service equipment on wall in permit location.
3. Customer shall supply, own and maintain the UG riser.
4. APS shall install underground service to entrance on a permanent basis.
5. Customer's installation shall be approved by the Inspection Agency.

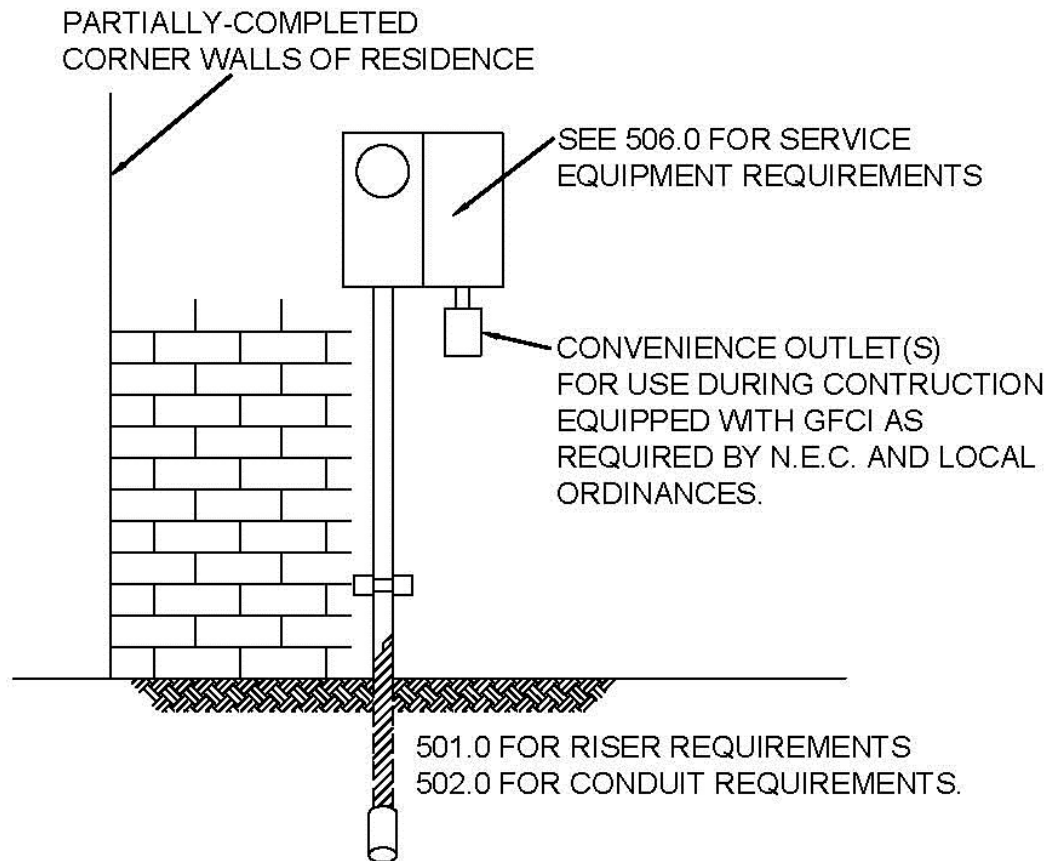

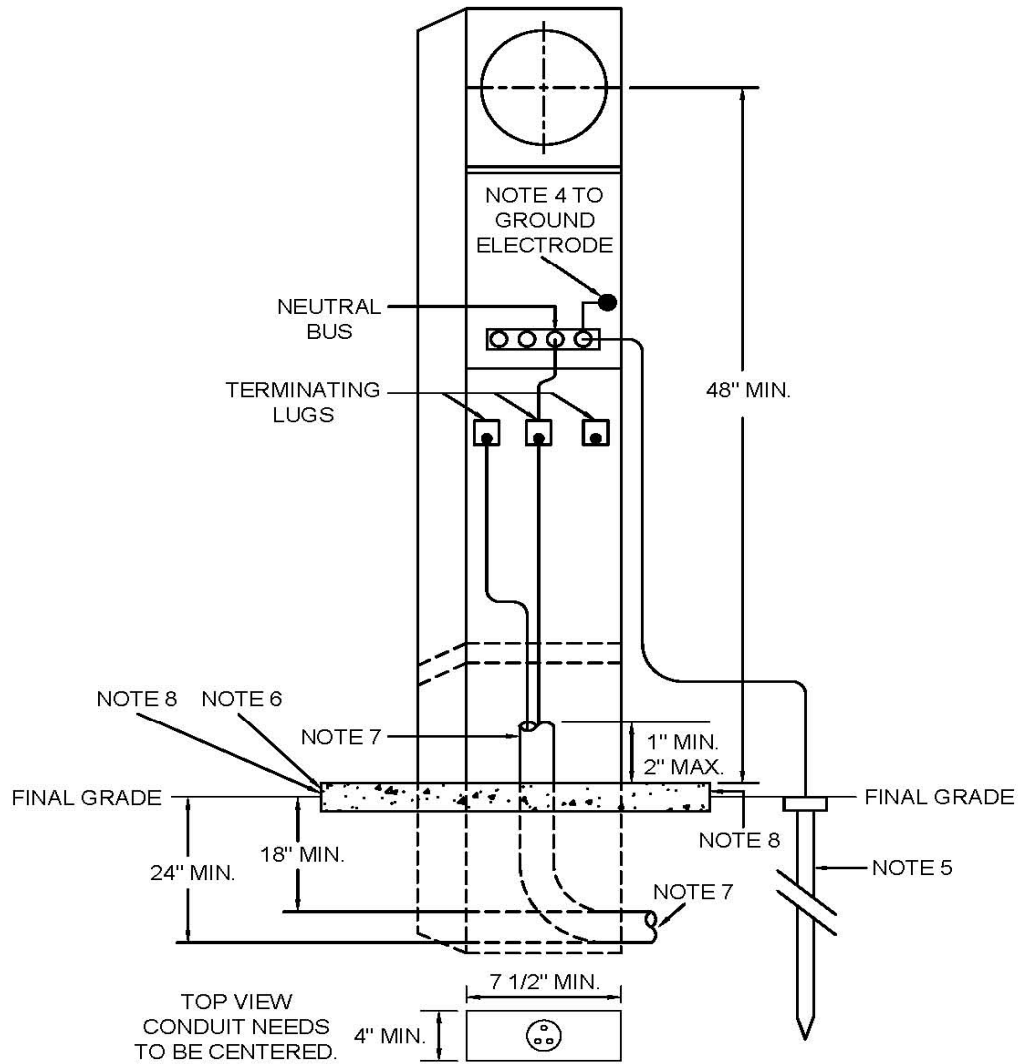

ALL DIMENSIONS SHOWN ARE IN INCHES.

PAGE 1 OF 2 FOR NOTES, SEE PAGE 25.

INSTALLATION GUIDELINES:

1. See Section 1100, DWG. 307 for meter pedestal requirements
2. Pedestal may be used as temporary for construction.
3. Pedestal and power outlet section shall be rated 10,000 A.I.C. minimum.
4. The grounding electrode conductor shall be continuous to the neutral landing block in the breaker compartment. Bare copper conductor may be used if properly supported. Connect pedestal bond lug as shown.
5. Grounding shall be provided by the Customer in compliance with the N.E.C. made electrodes shall have a resistance to ground of not more than 25 Ohms.
6. Poured concrete slab shall be 24" x 24" minimum size and have a 3 - ½ inch thickness.
7. Customer to provide and install 2 - ½ inch rigid PVC conduit and sweeps per 502.0. A 24" radius is required. Conduit to extend a minimum of 1" and a maximum of 2" above the concrete slab. (See Drawing). Cascaded pedestals are not allowed.
8. Customer shall be responsible for final grade of the utility island and the included meter pedestal.
9. Receptacle plugs, cords or "hard-wire" connections shall not block access to panel(s) covering service cable and termination pull section. (See Note 6)
10. Meter location to be approved by APS. See Section 300, Paragraph 301.3 for details.

INSTALLATION PROCEDURE FOR CUSOMERS

11. Set the meter pedestal in place over the 2 - ½" plastic service conduit.
12. Install the required size continuous grounding electrode conductor from an approved grounding electrode to the neutral bus in the breaker compartment.
Do Not Run the Grounding Electrode through the Service Pull Section. Bond the pedestal through its bonding lug with the grounding conductor as shown. Grounding the neutral landing block to the pedestal by means of a jumper or the grounding screw. (See DWG 303.13 Note 10)
13. Back fill around the pedestal, and compact fill to provide good support, plumb and level the pedestal, and pour the concrete slab. (See Note 17 above) Observe that the fixed panel for the final grade and concrete pour is positioned so access is properly maintained to the service lugs through the removal panels.
14. APS shall connect the service conductors to the service lugs in the meter pedestal, install and seal the pull section panel, and blank off and seal the meter socket ring. The meter shall be set upon completion of the application for service by the customer.
15. When the pedestal is used as temporary for construction power the edge of the pedestal concrete pad shall be a minimum of 2 feet from the edge of the transformer pad. Maximum distance shall be 10 feet from transformer pad. If terrain dictates a problem contact APS Customer Service Representative.

CAUTION – Before digging or driving ground rods be sure to notify Blue Stake or you local APS Office to locate underground facilities. See Section 100, Paragraph 100.12.

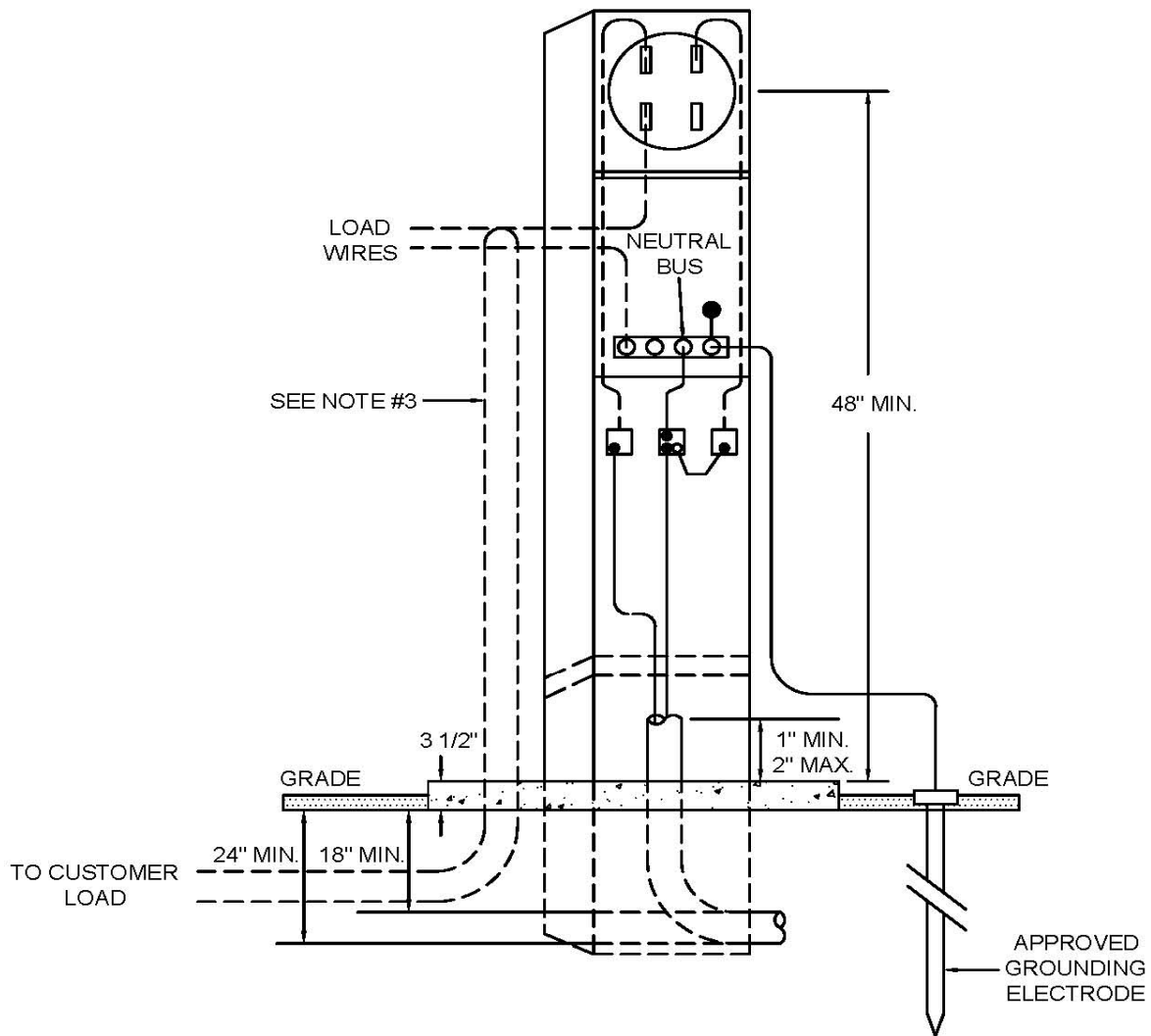

120 VOLT METERING PEDESTAL

PAGE 1 OF 2 – FOR NOTES, SEE PAGE 27.

506.7-2 TYPICAL 120 VOLT 2 WIRE PEDESTAL

(Page 2 of 2)

NOTES:

1. Meter Pedestal to be U.L. Listed. (As service Equipment)
2. See Section 1100, Dwg. 307 for Meter Pedestal Requirements
3. Load conductors shall not be run in Utility's service cable pull and termination section. Metallic conduit shall be wrapped or coated per Paragraph 501.4.
4. A 3 foot, minimum working space in front of any removable panel(s) is required.
5. Wiring from meter pedestal to customer equipment shall be installed per National Electric Code.
6. Meter location is to be approved by APS.
7. Pedestal may be used for metered cable TV Installations.

****For additional installation requirements, see Paragraph 506.6-2****

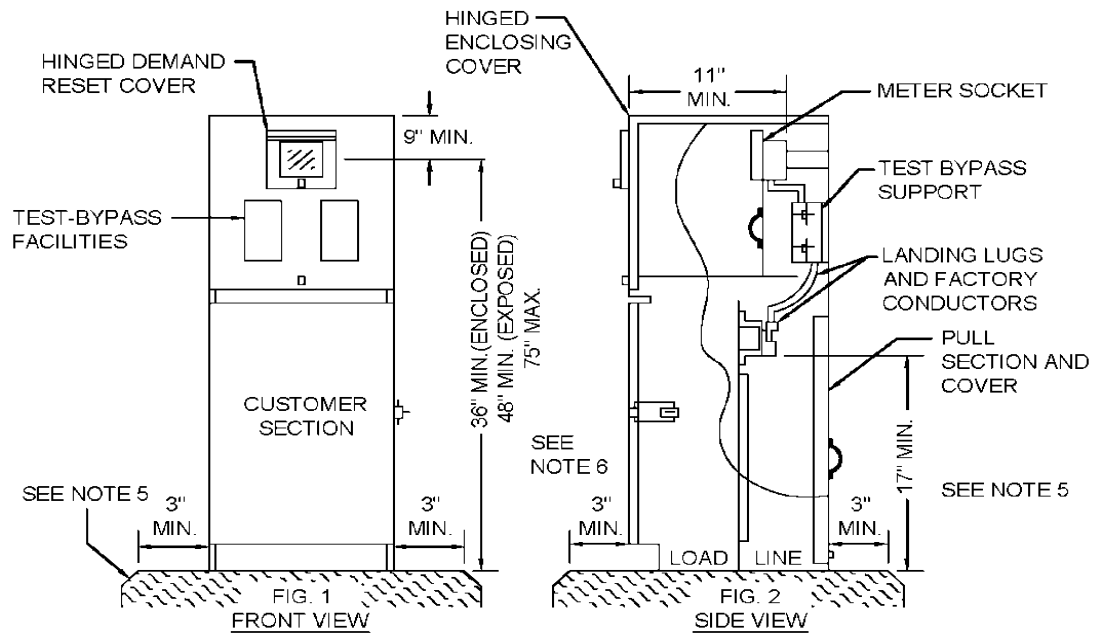

ALL DIMENSIONS SHOWN ARE IN INCHES

INSTALLATION GUIDELINES:

1. Pedestal shall be U.L. listed and EUSERC approved.
2. See Section 1100, DWG. 308 for meter pedestal requirements.
3. Pedestal and main disconnect shall be rated for the available fault current (A.I.C.). Check with APS representative to verify
4. The ground electrode conductor shall be continuous to the neutral landing block in the breaker compartment. The ground electrode conductor shall not pass through the pull section, service termination, or meter compartments of the pedestal.
5. Concrete foundation shall be a minimum size 24" x 24" x 6"
6. Acceptable to install ground rod and connected inside load compartment of SES

****Page 1 of 2 - for additional notes, see Page 29****

506.8-1 TYPICAL COMMERCIAL SERVICE AND METER PEDESTAL MAXIMUM 200 AMPS, 0-600 VOLTS

7. Meter location to be approved by APS. (See also Section 300, Paragraph 301.5)
8. Customers to provide and install rigid PVC conduit and sweeps per Paragraph 502.0. A 24" radius is required. Conduit to extend a minimum of 1 inch and a maximum of 2 inches above the concrete slab.
9. Conduit shall be sized per Paragraph 501.1-2 or 501.1-3
10. Customers shall be responsible for final grade of the utility island and the included meter pedestal.
11. APS Shall connect the service conductors to the service lugs in the meter pedestal, install and seal the pull section panel, and blank off and seal the meter socket ring. The meter shall be set upon completion of the application for service by the Customer.

CAUTION – Before digging or driving ground rods be sure to notify Blue Stake or you local APS Office to locate underground facilities. See Section 100, Paragraph 100.12.

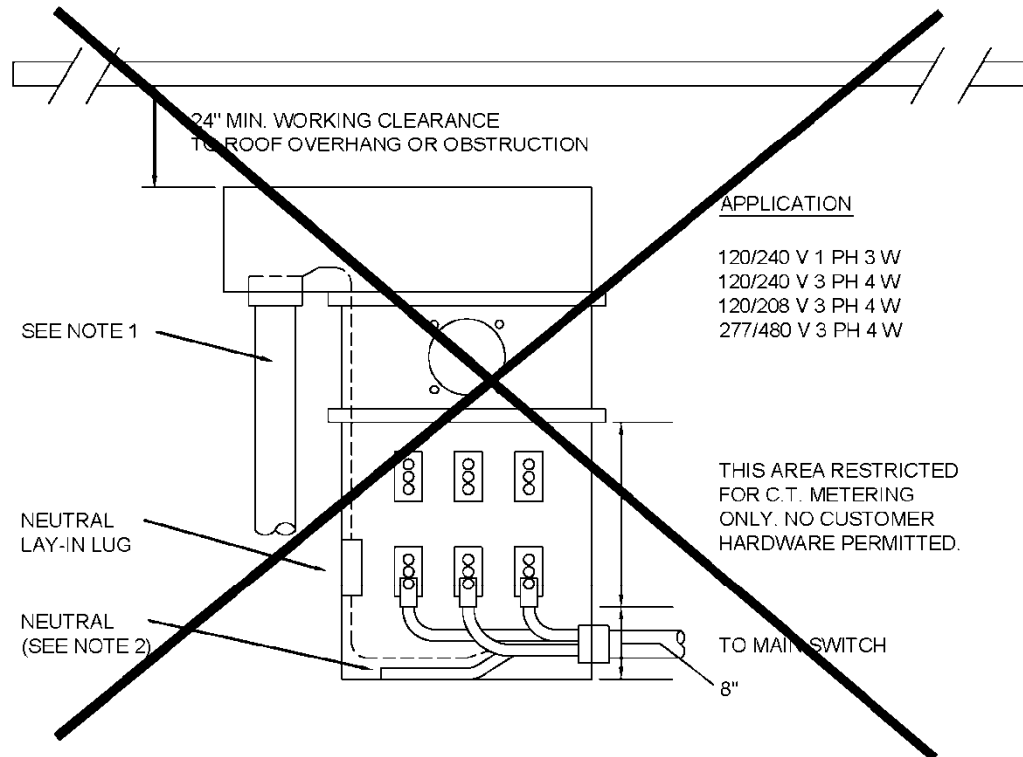
**NOTES:**

1. Side riser conduit will be existing panels, new panels will have their own pull-section.
2. The company furnishes and installs the C.T.'s test switch and connects the Customer's neutral. The Customer installs the meter socket. Customers to run neutral wire from main disconnect.
3. Service lines must be installed first before meter and CT's are installed.

OBSOLETE: FOR MAINTENANCE ONLY

506.11 S.E.S. UNDERGROUND 400 THROUGH 800 AMPS (FREE STANDING S.E.S.):

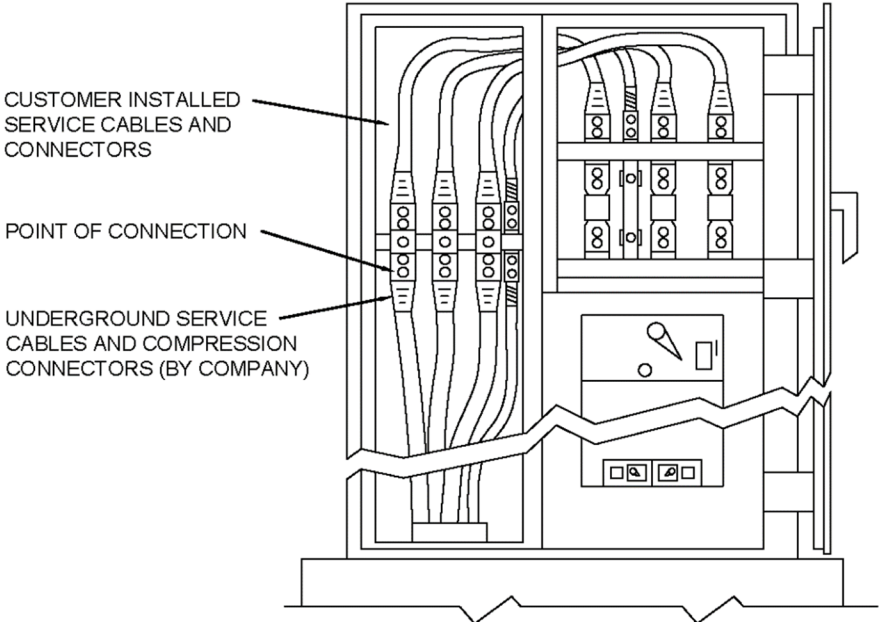

SEE SECTION 1100, DWGS. 345 & 347 FOR WIREWAY AND CABLE LANDING REQUIREMENTS.

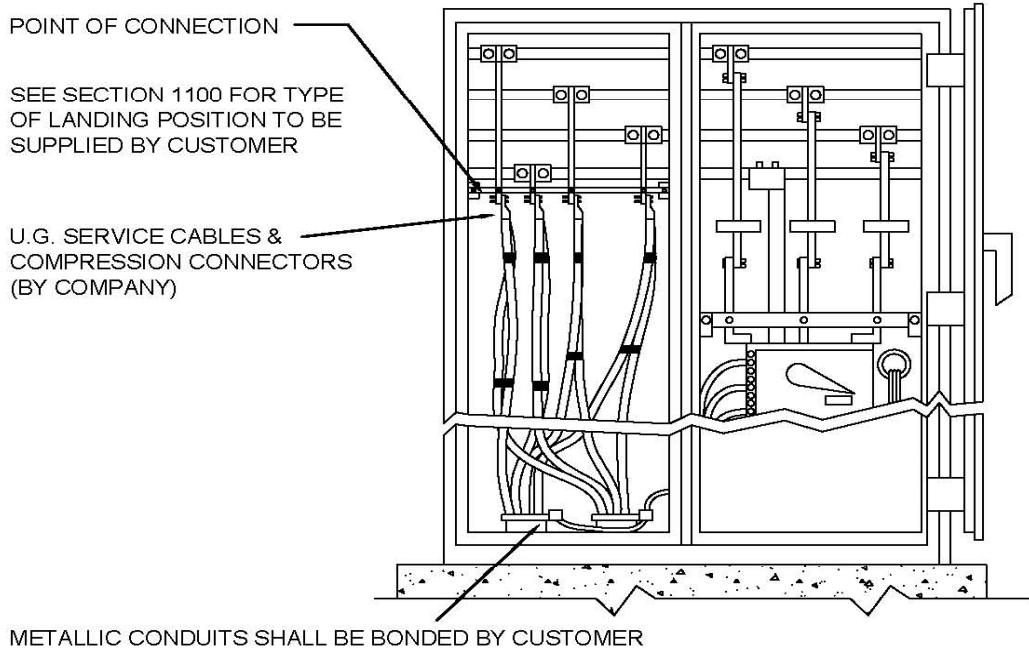

SEE SECTION 1100 DWGS. 345 & 347 FOR WIREWAY AND CABLE LANDING REQUIREMENTS.

OPTIONAL TOP ENTRY PULL SECTION FOR S.E.S. INSIDE BUILDINGS
(NOT APPLICABLE TO NETWORK INSTALLATIONS)

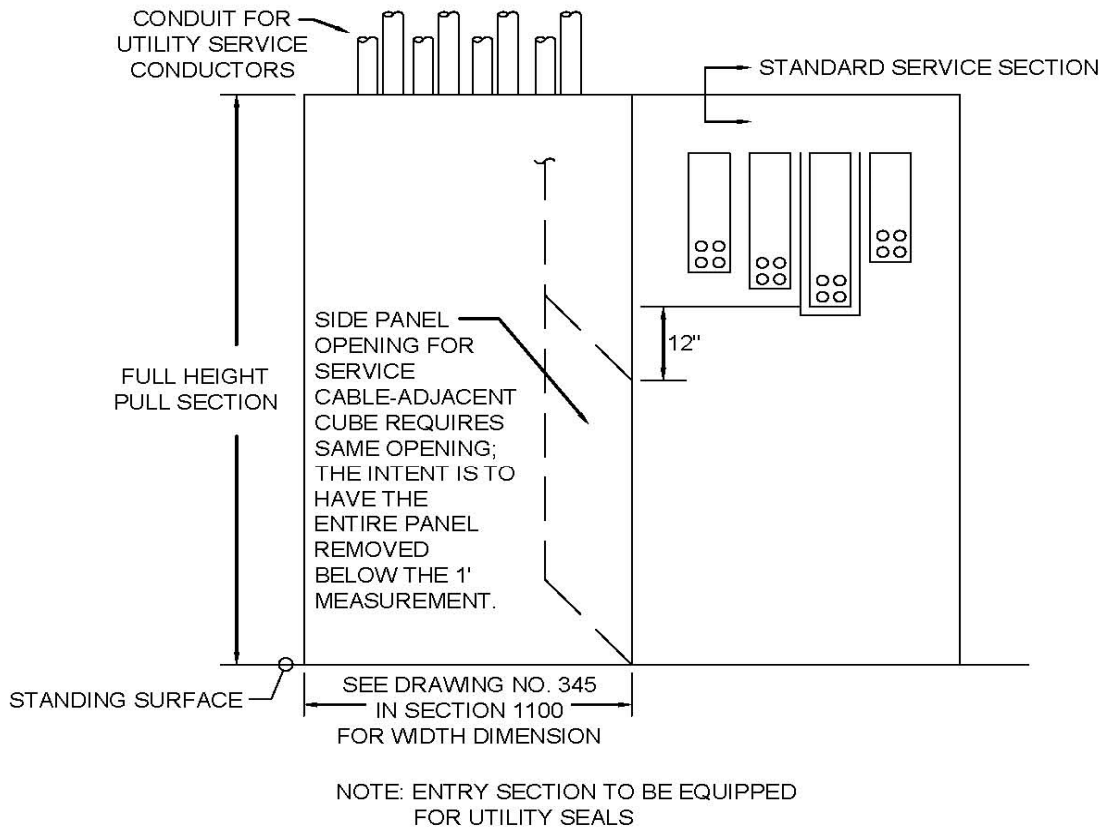

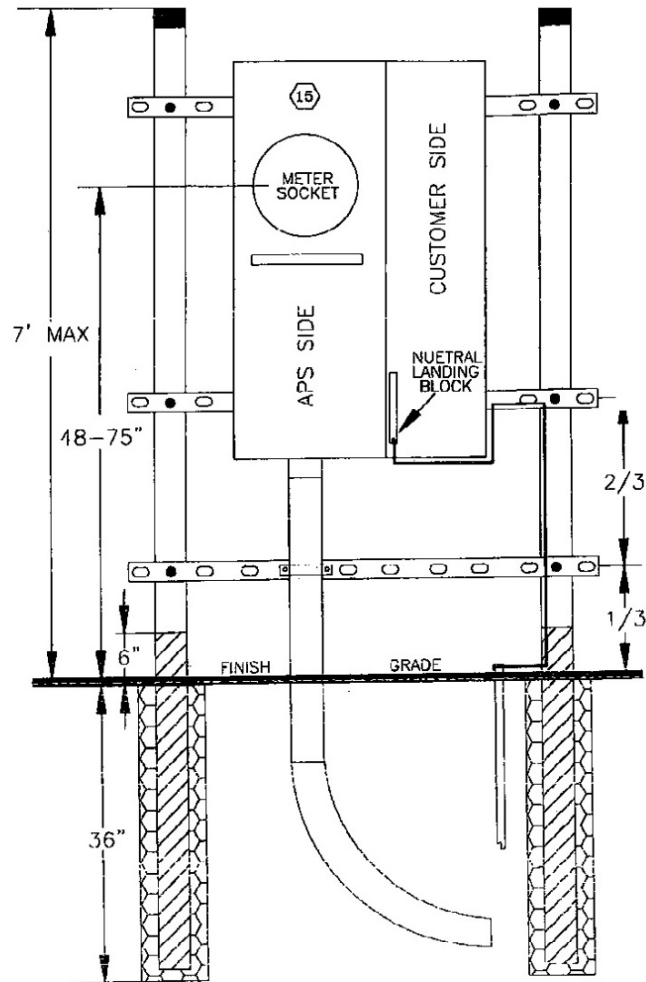
**NOTES:**

1. See Section 306.0 for complete breakdown of requirements
2. See Section 700 for grounding and bonding requirements.
3. Minimum dimensions of posts shall be.
 - a. Pipes posts = 3" in diameter. Pipe posts to be of rigid galvanized steel. (Maximum Length = 10")
4. The post shall be placed in the center of 12" minimum diameter concrete footing. The footing shall be a minimum of 36 inches in the ground and extend a minimum of 4 inches above ground level, and have a 1/2 inch slope away from the post to allow for drainage
5. All boards, steel and unistrut shall be attached to steel pole or post securely with a minimum 1/2" galvanized through bolt with a 1 1/2" galvanized backing and a lock nut. Nails or lag screws will not be acceptable.
6. All service equipment shall be securely fastened to steel with a minimum 1/4" through bolts. Nails or lag screws will not be acceptable.
7. Meter panel must meet APS requirements.
8. Customer to supply, own and maintain the UG riser.