

## **EQUIPMENT CLEARANCE REQUIREMENTS**

THIS DOCUMENT CONTAINS THE MINIMUM ELECTRICAL CLEARANCE REQUIREMENTS FOR APS PADMOUNTED TRANSFORMERS, SWITCHING CABINETS, AND CAPACITOR BANKS. DETAILS FOR EACH PIECE OF EQUIPMENT ARE SHOWN IN THE SUBSEQUENT SECTIONS ALONG WITH DETAILED CONSTRUCTION STANDARDS.

FROM A DESIGN STANDPOINT, THE FOLLOWING ITEMS SHALL BE ADHERED TO:

1. THE CLEARANCES DOCUMENTED IN THIS SECTION ARE REQUIRED TO SAFELY OPERATE AND MAINTAIN THE EQUIPMENT AND SHALL BE ACCESSIBLE AT ALL TIMES.
2. THESE ELECTRICAL CLEARANCES, WHEN USED IN CONJUNCTION WITH ACCESS REQUIREMENTS (ESRM SECTION 1400.0), PROVIDE ADEQUATE SPACE FOR APS VEHICLES AND PERSONNEL TO ACCESS, MAINTAIN AND OPERATE THE EQUIPMENT.
3. LAND USE AND OWNERSHIP CHANGES OVER TIME. EQUIPMENT CLEARANCES MAY BE ON PUE, RIGHT OF WAY, OR CUSTOMER PROPERTY.
4. CLEARANCE AREAS SHALL NOT BE ON THIRD PARTY PRIVATE PROPERTY WITHOUT A DEDICATED EASEMENT IN PLACE.
5. CLEARANCE AREAS SHALL NOT OVERLAP WITH AREAS OF RESTRICTED USE BY OTHER JURISDICTIONS (I.E. FIRE LANES).
6. CLEARANCE AREAS SHALL NOT OVERLAP WITH DRIVABLE SURFACES OR AREAS ACCESSIBLE TO VEHICLES.  
EXCEPTIONS:
  - a. PARKING LOTS MAY SHARE THE CLEARANCE AREA PROVIDED THERE IS NO OVERLAP WITH DEDICATED PARKING SPACES, ENTRIES, OR EXITS.
  - b. SINGLE PHASE TRANSFORMERS IN RESIDENTIAL APPLICATIONS WHERE VEHICLE SPEEDS ARE LIMITED TO 25MPH.
7. CLEARANCE AREAS SHALL BE SMOOTH AND FREE OF OBSTRUCTIONS SUCH AS PLANTS AND CACTUS; AND TRIPPING HAZARDS SUCH AS CURBS AND RIVER ROCK.

WORK WITH YOUR APS REPRESENTATIVE TO IDENTIFY SAFE LOCATIONS FOR EQUIPMENT. ALL EQUIPMENT AND FACILITY LOCATIONS SHALL BE APPROVED AND DESIGNED BY APS.



**TRANSFORMER CLEARANCES**

**1 PHASE TRANSFORMER CLEARANCE DETAIL**

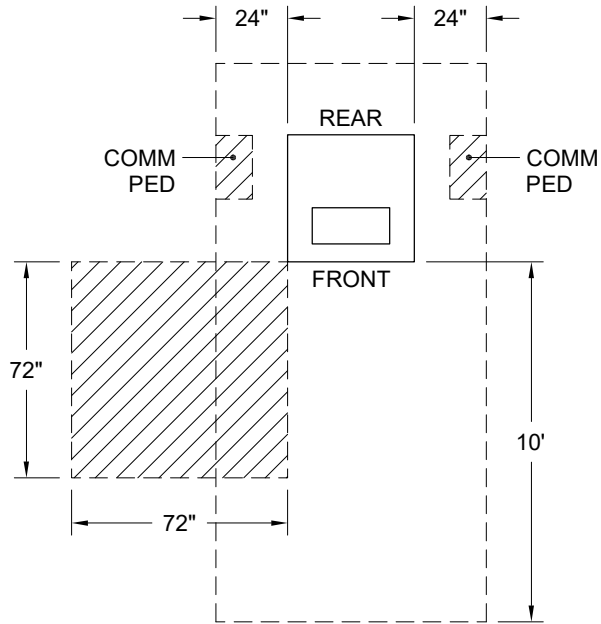

**112.5-750kVA 3 PHASE TRANSFORMER CLEARANCE DETAIL**

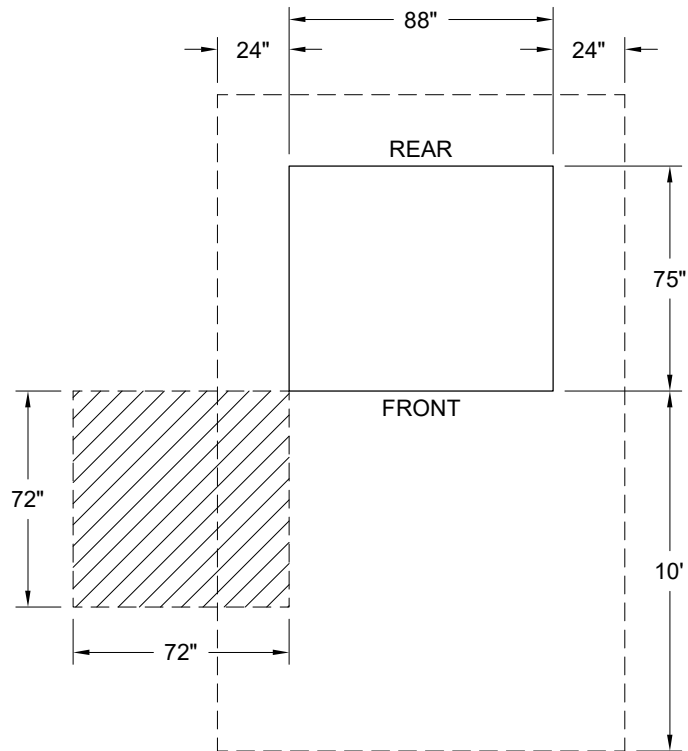

**TRANSFORMER CLEARANCES**

1000-2500kVA 3 PHASE TRANSFORMER CLEARANCE DETAIL

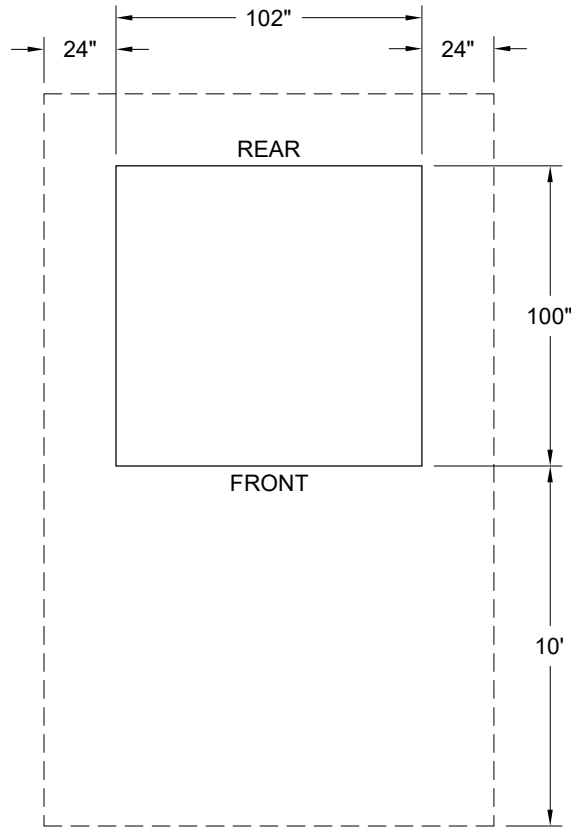

**TRANSFORMER CLEARANCE REQUIREMENTS**

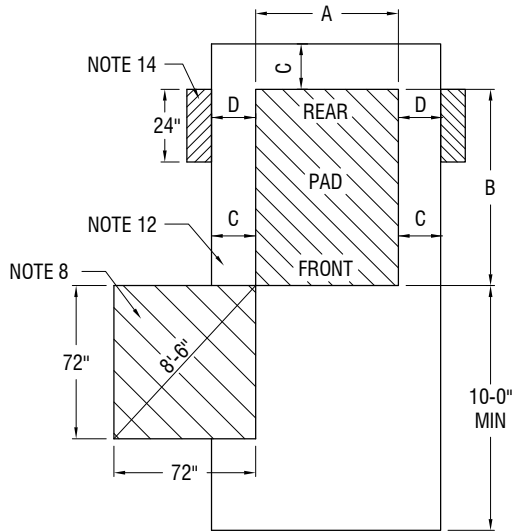

FIGURE 1 - CLEARANCE DIMENSIONS

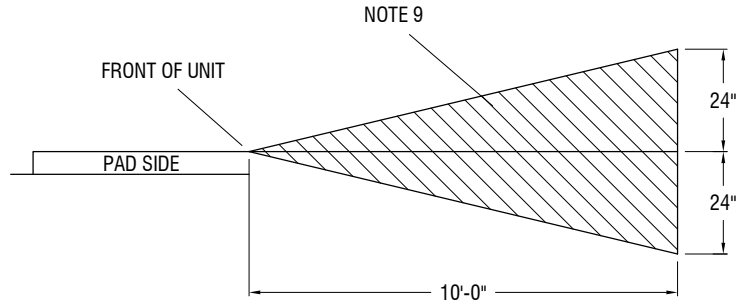

FIGURE 2 - SLOPE CRITERIA

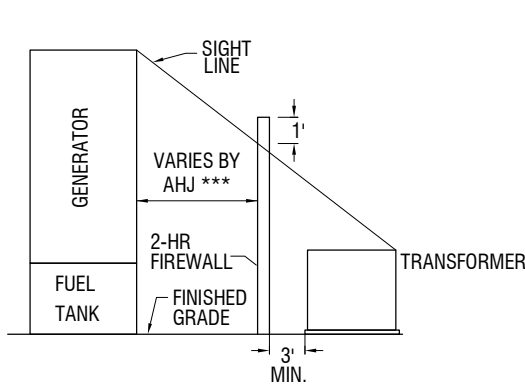

FIGURE 3 - FIRE WALL HEIGHT

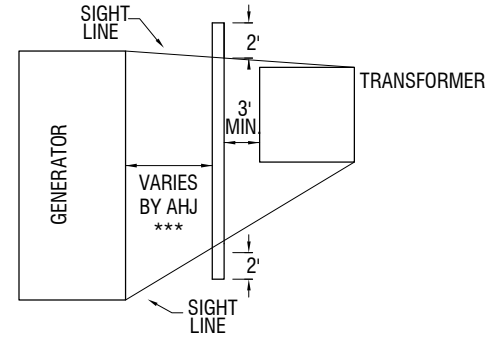

FIGURE 4 - FIRE WALL LENGTH

\*\*\* AHJ - AUTHORITIES HAVING JURISDICTION

CONSTRUCTION STANDARD	PAD USAGE	PAD DIMENSION		MINIMUM CLEARANCES		
		A	B	TO BUILDINGS	TO FENCES	TO COMM. PED
		C	C	D		
7620 7621	1Ø DUMMY CABINET	42"	42"	24" VARIES BY AHJ *** ↑	12"	12"
7620	1Ø LOW PROFILE TRANSFORMER 25-75KVA	42"	42"			
7628	1Ø LOW PROFILE TRANSFORMER 100-167KVA	42"	48"			
7630	1Ø BOX PAD INSTALLATION	57"	57"			
7640-1 7648-53	3Ø TWO TRANSFORMER BANK	90"	48"			
7661-7	3Ø 75-750KVA TRANSFORMER	88"	75"	24"		
	3Ø 1000-2500KVA TRANSFORMER	102"	100"			

**NOTES:**

1. THE FINAL GRADE AT THE PAD POSITION SHALL BE COMPACTED AND LEVELED TO ENSURE A MAXIMUM 2-DEGREE TILT OF THE PAD, FOR EXAMPLE, A 42-INCH SQUARE PAD SHALL BE LEVEL WITHIN 1-1/2 INCHES FROM SIDE-TO-SIDE AND FRONT-TO-BACK.
2. THE FINAL GRADE WITHIN THE 10-FOOT OPERATING AREA SHALL BE SMOOTH AND STABLE ENOUGH TO PROVIDE A SUITABLE WALKING AND WORKING SURFACE. TRIPPING HAZARDS SUCH AS CURBS OR RIVER ROCK ARE NOT ACCEPTABLE IN THIS LOCATION.
3. WHEN AN ENCLOSURE IS INSTALLED NEAR A SIDEWALK OR CURB, SET THE BOTTOM OF THE PAD AT THE SAME GRADE AS THE TOP OF THE SIDEWALK OR CURB FOR BETTER APPEARANCE AND DRAINAGE. FRONT OF PAD SHOULD BE 12" TO 18" MINIMUM FROM BACK OF SIDEWALK.
4. SLOPE CRITERIA AS SHOWN GIVES RECOMMENDED NORMAL FRONTAL SLOPE LIMITS. CONSIDERATION FOR EXCEPTIONS BY TURNING TRANSFORMERS AWAY FROM FACING THE STREET AND/OR EXCEEDING THESE SLOPE LIMITS REQUIRES SPECIAL DIVISION ENGINEERING AND OPERATIONS APPROVAL, PRIOR TO CONSTRUCTION.
5. ALL DIMENSIONS ARE MEASURED FROM THE EQUIPMENT PAD EDGE.
6. A MINIMUM 30-FOOT VERTICAL CLEARANCE IS REQUIRED FROM FINISHED GRADE IN APS EQUIPMENT AREAS TO ABOVE SURROUNDING UNOBSTRUCTED STAGING AREAS. THE 30-FOOT VERTICAL CLEARANCE SHALL ALSO APPLY TO CUSTOMER'S OVERHEAD STRUCTURES ABOVE BURIED APS ELECTRICAL FACILITIES/RIGHT-OF-WAY. REMOVABLE OVERHEAD STRUCTURES SUCH AS SHADE CANOPIES ARE EXEMPTED.
7. SIDE-BY-SIDE TRANSFORMERS REQUIRE A MINIMUM 24-INCH HORIZONTAL CLEARANCE. DUPLEX TRANSFORMERS SET ON A SINGLE PAD ARE AN EXCEPTION.
8. A MINIMUM 72-INCH X 72-INCH CLEAR WORKING SPACE SHALL BE PROVIDED FOR HOTSTICK TOOL OPERATION - SEE FIGURE 1. THIS WORKING SPACE IS REQUIRED FOR 750 KVA TRANSFORMERS AND SMALLER. TRANSFORMERS 1000 KVA AND LARGER DO NOT REQUIRE THIS WORKING SPACE. PREFERABLY, STREETLIGHT POLES SHOULD BE INSTALLED OUTSIDE OF THIS WORKING SPACE, BUT IF FIELD CONDITIONS PRECLUDE THIS, THEN STREET LIGHT POLES MAY BE INSTALLED IN THIS SPACE.
9. AN ELEVATION CHANGE WITHIN THE 10-FOOT FRONTAL OPERATING AREA SHALL NOT EXCEED 24-INCHES IN ANY DIRECTION. GRADE PROFILE CHANGES MUST REMAIN WITHIN THE SHADED AREA SHOWN. SEE FIGURE 2.
10. A MINIMUM 36-INCHES HORIZONTAL PAD CLEARANCE IS REQUIRED FROM GAS REGULATORS, GAS METERS AND ELECTRIC METERS.
11. A MINIMUM 60-INCHES HORIZONTAL PAD CLEARANCE IS REQUIRED FROM FIRE HYDRANTS EXCEPTION THE CITY OF PHOENIX REQUIRES A 72-INCH CLEARANCE.
12. A MINIMUM 60-INCH WIDE, OPEN AND CONTINUOUSLY UNOBSTRUCTED ACCESS AND EXIT PATH SHALL BE PROVIDED TO AND FROM ALL OPERATING AREAS OF ANY UNIT(S) TO FACILITATE EASE OF ENTRY AND DEPARTURE.
13. A MINIMUM 20-FOOT SEPARATION/CLEARANCE IS REQUIRED BETWEEN APS ELECTRICAL FACILITIES IN OUTDOOR LOCATIONS WHERE FIRE OR EXPLOSION HAZARDS MAY EXIST.

THE 20-FOOT SEPARATION/CLEARANCE ALSO APPLIES BETWEEN APS PAD MOUNTED EQUIPMENT AND CUSTOMER'S INSTALLED GENERATORS UTILIZING ANY OF THE FOLLOWING FUELS:

- GASOLINE
- DIESEL FUEL
- COMPRESSED NATURAL GAS (CNG)
- LIQUEFIED NATURAL GAS (LNG)
- LIQUEFIED PETROLEUM GAS (LPG)
- HYDROGEN IN A GASEOUS FORM (GH2)
- HYDROGEN IN A LIQUID FORM (LH2)

IF THE MINIMUM 20-FOOT SEPARATION CAN NOT BE MAINTAINED, A FIRE BARRIER / FIRE WALL SHALL BE INSTALLED BETWEEN THE EQUIPMENT AND THE GENERATOR.

THE FIRE BARRIER / FIRE WALL SHALL HAVE A MINIMUM 2-HOUR FIRE RATING. THE FIRE WALL HEIGHT SHALL EXTEND AT LEAST 1-FOOT ABOVE THE LINE OF SIGHT BETWEEN ANY POINT ON THE TOP OF THE EQUIPMENT AND ANY POINT ON THE TOP OF THE GENERATOR. THE FIRE WALL SHALL ALSO EXTEND AT LEAST 2-FEET HORIZONTALLY BEYOND THE LINE OF SIGHT BETWEEN ANY POINT OF THE EQUIPMENT AND ANY POINT OF THE GENERATOR. A MINIMUM OF 3-FEET SEPARATION SHALL BE MAINTAINED BETWEEN THE FIRE WALL AND SIDE OF APS PAD MOUNTED EQUIPMENT EXCEPT FROM THE SIDE OF AN AUTOMATIC TRANSFER SWITCH CONTAINING THE CONTROL BOX WHERE A 6-FOOT SEPARATION SHALL BE MAINTAINED. SEE FIGURES 3 AND 4 FOR ILLUSTRATION.

WHERE THE DEGREE OF HAZARD IS UNKNOWN, CONTACT RISK MANAGEMENT / PUBLIC SAFETY FOR PROPER CLASSIFICATION OF THE HAZARDOUS LOCATIONS.

14. A COMMUNICATIONS PEDESTAL MAY ONLY BE PLACED WITHIN THE REAR 24-INCHES OF THE TRANSFORMER PAD AS SHOWN. THE DETAIL ADDRESSES RESIDENTIAL USE ONLY.
15. TRANSFORMER DOORS SHALL BE ORIENTED SO AS NOT TO OPEN TOWARDS THE STREET.  
EXCEPTION:  
SINGLE-PHASE TRANSFORMERS MAY BE FACED TOWARDS THE STREET PROVIDED THEY ARE SET BACK FROM THE ROADWAY TO MEET THE CLEARANCE REQUIREMENTS OF THIS STANDARD.
16. A MINIMUM OF 2-FOOT CLEARANCE SHALL BE MAINTAINED BETWEEN THE EDGE OF THE TREE ROOT BALL AND THE EDGE OF THE DUCT BANK WHEN TREES ARE PLANTED NEAR APS UNDERGROUND FACILITIES.
17. THE CLEARANCE AREA FOR ANY EQUIPMENT SHALL NOT OVERLAP WITH AREAS OF RESTRICTED USE BY OTHER JURISDICTIONS (I.E. FIRE LANES).
18. THE CLEARANCE AREA SHALL NOT BE A DRIVABLE AREA THAT IS ACCESSIBLE TO VEHICULAR TRAFFIC.  
EXCEPTIONS:  
A) PARKING LOTS MAY SHARE THE CLEARANCE AREA PROVIDED THERE IS NO OVERLAP WITH DEDICATED PARKING SPACES, ENTRIES, OR EXITS.  
B) SINGLE PHASE TRANSFORMERS IN RESIDENTIAL APPLICATIONS WHERE VEHICLE SPEEDS ARE LIMITED TO 25MPH.

**REFERENCES:**

1. NESC 2007, RULE 127.



**CAPACITOR BANK CLEARANCES**

12KV CAPACITOR BANK CLEARANCE DETAIL

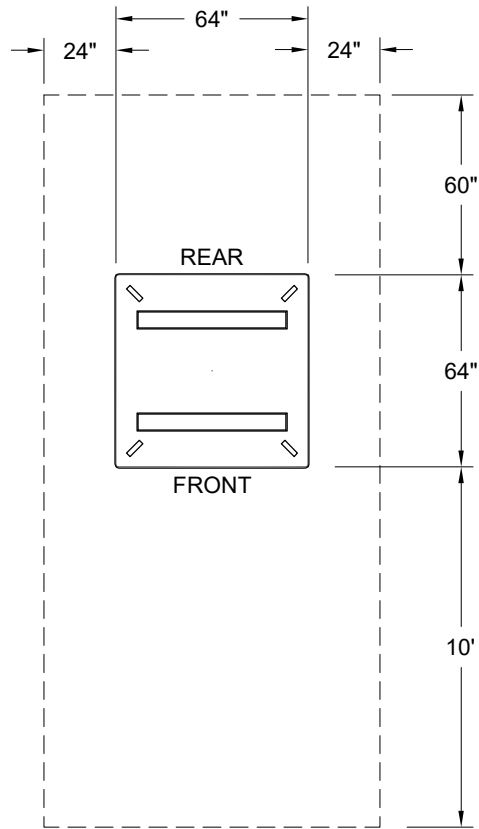

21KV CAPACITOR BANK CLEARANCE DETAIL

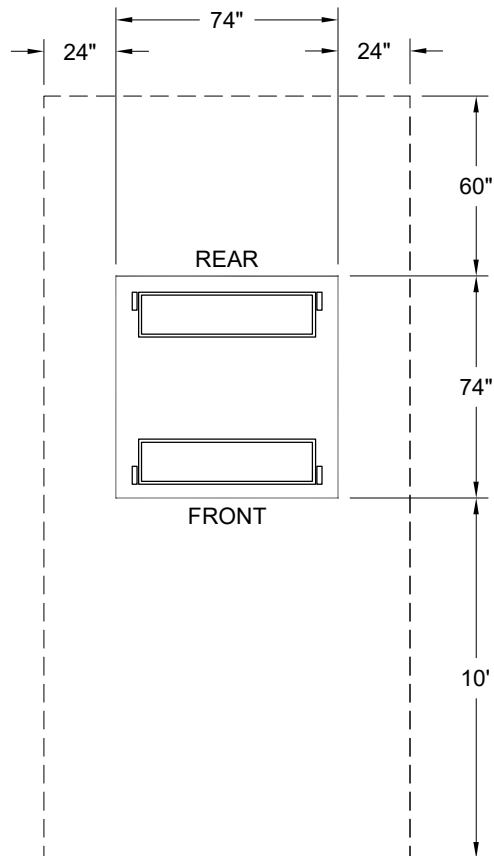

**SWITCHING CABINET CLEARANCES**

12kV SWITCHING CABINET CLEARANCE DETAIL

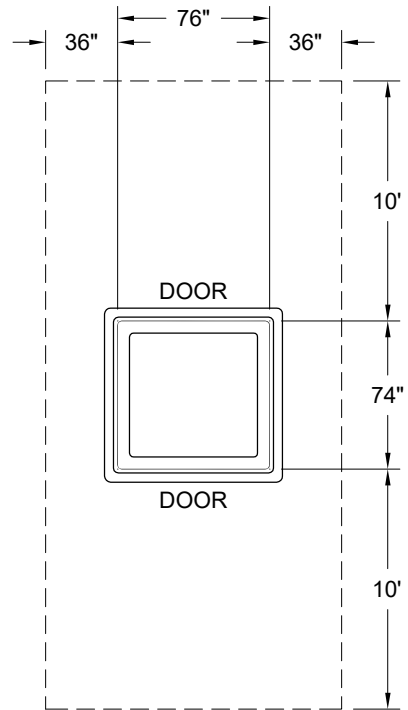

21kV SWITCHING CABINET CLEARANCE DETAIL

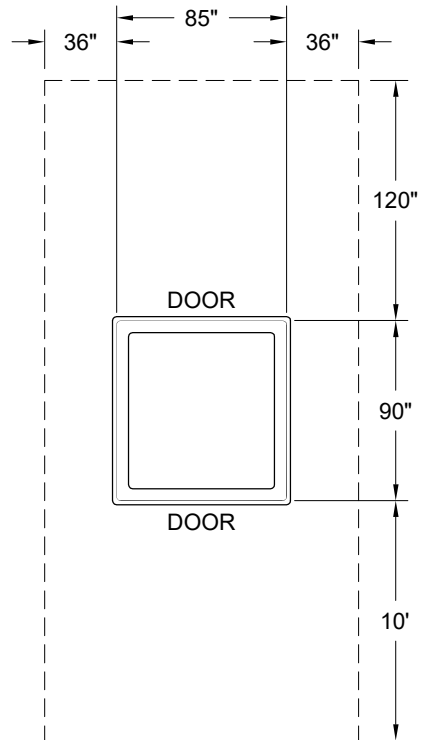

**CABINET CLEARANCE REQUIREMENTS**

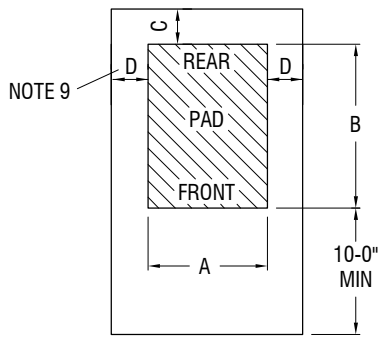

FIGURE 1 - CLEARANCE DIMENSIONS

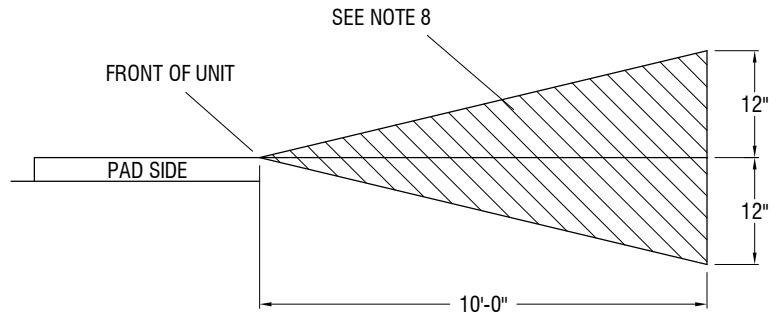

FIGURE 2 - SLOPE CRITERIA

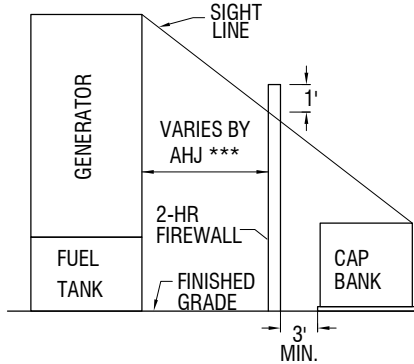

FIGURE 3 - FIRE WALL HEIGHT

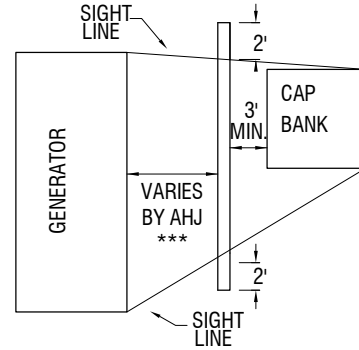

FIGURE 4 - FIRE WALL LENGTH

\*\*\* AHJ - AUTHORITIES HAVING JURISDICTION

CONSTRUCTION STANDARD	PAD USAGE	MINIMUM CLEARANCES					
		PAD DIMENSION		TO BUILDINGS		TO FENCES	
		A	B	C	D*	C	D
1386	CAPACITOR BANK 12 KV	64"	64"	60"	24"	60"	24"
1388	CAPACITOR BANK 21 KV	74"	74"				
8315	PMH-9 AUTOMATIC TRANSFER SWITCH 12KV	69"	63"	120"	36"***	120"	36"***
8330	560 A RECLOSER 12KV	76"	74"	24"	24"	24"	24"
8390	600 AMP METAL ENCLOSED SWITCHGEAR	VAR	56"	0" ^	24"	0" ^	24"
8391	1200 AMP METAL ENCLOSED SWITCHGEAR	VAR	56"	0" ^	24"	0" ^	24"
8400	200A C-I DISTRIBUTION CENTER	64"	64"	120"	24"	120"	24"
8410	3Ø 200A JUNCTION CABINET	78"	22"	24"	36"	24"	36"
8420	1Ø 4 WAY JUNCTION CABINET	42"	42"	24"	24"	12"	12"
8422	1Ø 6 WAY JUNCTION CABINET	48"	19"				
8430	FUSED SECTIONALIZING ENCLOSURE	42"	42"	120"	24"	120"	24"
8450	600A C-I DISTRIBUTION CENTER	74"	74"	120"	36"***	120"	36"
8475	600A C-I DISTRIBUTION CENTER 12KV	76"	74"				
8477	600A C-I DISTRIBUTION CENTER 21KV	85"	90"				
8500	600A P-I DISTRIBUTION CENTER	76"	74"	120"	24"	120"	24"
8502	600A P-I DISTRIBUTION CENTER SLIMLINE	141"	38"	24"	24"	24"	24"
8508	1Ø OR 3Ø TERMINATION CABINET	42"	42"	24"	24"	12"	12"
8510	600A TERMINATION CABINET	47"	32"	120"	24"	120"	24"

\* A MINIMUM 24-INCH SEPARATION IS ALSO REQUIRED BETWEEN THE SIDES OF A CABINET AND WATER METER BOXES, COMMUNICATION PEDESTALS AND STREET LIGHT POLES.

\*\* A MINIMUM 72-INCH SEPARATION IS REQUIRED FROM SIDE OF THE AUTOMATIC TRANSFER SWITCH CONTAINING THE CONTROL BOX.

^ NO CLEARANCE IS REQUIRED FOR THE BACKSIDE OF METAL ENCLOSED SWITCHGEAR. IF EGRESS IS NEEDED, 24" MAY BE USED FOR THESE DIMENSIONS.



**NOTES:**

1. FINAL GRADE AT THE PAD POSITION SHALL BE COMPACT AND LEVEL TO ENSURE A MAXIMUM 2-DEGREE TILT OF THE PAD. FOR EXAMPLE, A 48-INCH SQUARE PAD SHALL BE LEVEL WITHIN 1-3/4 INCHES FROM SIDE-TO-SIDE AND FRONT-TO-BACK.
2. THE FINAL GRADE WITHIN THE 10-FOOT OPERATING AREA SHALL BE SMOOTH AND STABLE ENOUGH TO PROVIDE A SUITABLE WALKING AND WORKING SURFACE. TRIPPING HAZARDS SUCH AS CURBS OR RIVER ROCK ARE NOT ACCEPTABLE IN THIS LOCATION.
3. WHEN AN ENCLOSURE IS INSTALLED NEAR A SIDEWALK OR CURB, SET THE BOTTOM OF THE PAD AT THE SAME GRADE AS THE TOP OF THE SIDEWALK OR CURB FOR BETTER APPEARANCE AND DRAINAGE. FRONT OF PAD SHOULD BE 12" TO 18" MINIMUM FROM BACK OF SIDEWALK.
4. SLOPE CRITERIA AS SHOWN GIVES RECOMMENDED NORMAL FRONTAL SLOPE LIMITS. CONSIDERATION FOR EXCEPTIONS BY TURNING CABINETS AWAY FROM FACING THE STREET AND/OR EXCEEDING THESE SLOPE LIMITS REQUIRES SPECIAL DIVISION ENGINEERING AND OPERATIONS APPROVAL, PRIOR TO CONSTRUCTION.
5. ALL DIMENSIONS ARE MEASURED FROM THE EQUIPMENT PAD EDGE.
6. A MINIMUM 30-FOOT VERTICAL CLEARANCE IS REQUIRED FROM FINISHED GRADE IN APS EQUIPMENT AREAS TO ABOVE SURROUNDING UNOBSTRUCTED STAGING AREAS. THE 30-FOOT VERTICAL CLEARANCE SHALL ALSO APPLY TO CUSTOMER'S OVERHEAD STRUCTURES ABOVE BURIED APS ELECTRICAL FACILITIES / RIGHT-OF-WAY. REMOVABLE OVERHEAD STRUCTURES SUCH AS SHADE CANOPIES ARE EXEMPTED.
7. SIDE-BY-SIDE EQUIPMENT REQUIRES A MINIMUM 24-INCH HORIZONTAL CLEARANCE. EXCEPTION: 3 FEET IS REQUIRED FROM CIRCUIT-ISOLATED ENCLOSURES.
8. AN ELEVATION CHANGE WITHIN THE 10-FOOT FRONTAL OPERATING AREA SHALL NOT EXCEED 12-INCHES IN ANY DIRECTION. GRADE PROFILE CHANGES MUST REMAIN WITHIN THE SHADED AREA SHOWN. SEE FIGURE 2.
9. MINIMUM 60-INCH WIDE, OPEN AND CONTINUOUSLY UNOBSTRUCTED ACCESS AND EXIT PATH SHALL BE PROVIDED TO AND FROM ALL OPERATING AREAS OF ANY UNIT(S) TO FACILITATE EASE OF ENTRY AND DEPARTURE.
10. MINIMUM 36-INCH HORIZONTAL PAD CLEARANCE IS REQUIRED FROM GAS REGULATORS, GAS METERS AND ELECTRIC METERS.
11. MINIMUM 60-INCH HORIZONTAL PAD CLEARANCE IS REQUIRED FROM FIRE HYDRANTS EXCEPTION: THE CITY OF PHOENIX REQUIRES A 72-INCH CLEARANCE.
12. ALL PAD-MOUNTED EQUIPMENT OF GREATER HEIGHT THAN 36-INCHES SHALL BE LOCATED A SUFFICIENT DISTANCE FROM ROADWAY INTERSECTIONS AND/OR DRIVEWAY ENTRANCES TO AVOID CREATING A VISUAL OBSTRUCTION TO TRAFFIC.
13. A MINIMUM 20-FOOT SEPARATION / CLEARANCE IS REQUIRED BETWEEN APS ELECTRICAL FACILITIES IN OUTDOOR LOCATIONS WHERE FIRE OR EXPLOSION HAZARDS MAY EXIST.  
  
THE ABOVE SEPARATIONS ALSO APPLY BETWEEN APS PAD MOUNTED EQUIPMENT AND CUSTOMER'S INSTALLED GENERATORS UTILIZING ANY OF THE FOLLOWING FUELS:  
GASOLINE  
DIESEL FUEL  
COMPRESSED NATURAL GAS (CNG)  
LIQUEFIED NATURAL GAS (LNG)  
LIQUEFIED PETROLEUM GAS (LPG)  
HYDROGEN IN A GASEOUS FORM (GH2)  
HYDROGEN IN A LIQUID FORM (LH2)  
  
IF THE MINIMUM 20-FOOT SEPARATION CAN NOT BE MAINTAINED, A FIRE BARRIER / FIRE WALL SHALL BE INSTALLED BETWEEN THE EQUIPMENT AND THE GENERATOR.  
  
THE FIRE BARRIER / FIRE WALL SHALL HAVE A MINIMUM 2-HOUR FIRE RATING. THE FIRE WALL HEIGHT SHALL EXTEND AT LEAST 1-FOOT ABOVE THE LINE OF SIGHT BETWEEN ANY POINT ON THE TOP OF THE EQUIPMENT AND ANY POINT ON THE TOP OF THE GENERATOR. THE FIRE WALL SHALL ALSO EXTEND AT LEAST 2-FEET HORIZONTALLY BEYOND THE LINE OF SIGHT BETWEEN ANY POINT OF THE EQUIPMENT AND ANY POINT OF THE GENERATOR. A MINIMUM OF 3-FEET SEPARATION SHALL BE MAINTAINED BETWEEN THE FIRE WALL AND SIDE OF APS PAD MOUNTED EQUIPMENT EXCEPT FROM THE SIDE OF AN AUTOMATIC TRANSFER SWITCH CONTAINING THE CONTROL BOX WHERE A 6-FOOT SEPARATION SHALL BE MAINTAINED. SEE FIGURES 3 AND 4 FOR ILLUSTRATION.  
  
WHERE THE DEGREE OF HAZARD IS UNKNOWN, CONTACT RISK MANAGEMENT / PUBLIC SAFETY FOR PROPER CLASSIFICATION OF THE HAZARDOUS LOCATIONS.
14. ENCLOSURES SHALL BE ORIENTED SO THAT THE DOORS DO NOT OPEN TOWARDS THE STREET.
15. A MINIMUM OF 2-FOOT CLEARANCE SHALL BE MAINTAINED BETWEEN THE EDGE OF THE TREE ROOT BALL AND THE EDGE OF THE DUCT BANK WHEN TREES ARE PLANTED NEAR APS UNDERGROUND FACILITIES.
16. THE CLEARANCE AREA FOR ANY EQUIPMENT SHALL NOT OVERLAP WITH AREAS OF RESTRICTED USE BY OTHER JURISDICTIONS (I.E. FIRE LANES).
17. THE CLEARANCE AREA SHALL NOT BE A DRIVABLE AREA THAT IS ACCESSIBLE TO VEHICULAR TRAFFIC.  
EXCEPTION:  
A) PARKING LOTS MAY SHARE THE CLEARANCE AREA, PROVIDED THERE IS NO OVERLAP WITH DEDICATED PARKING SPACES, ENTRIES, OR EXITS.

**REFERENCES:**

1. NESC 2007, RULE 127.

